

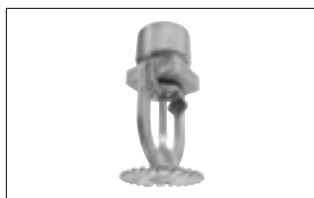

# Model F1 Res and RFC Residential Sprinkler Design and Installation Guide



F1 Res 30/30LL, 49/49LL,  
58/58LL & 76  
Pendent



F1 Res 30/30LL, 49/49LL,  
58/58LL & 76  
Recessed Pendent / F1

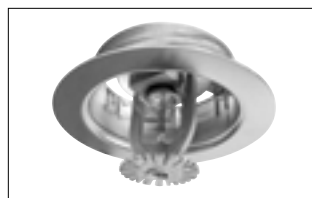

F1 Res 30/30LL, 49/49LL,  
58/58LL & 76  
Recessed Pendent / FP



F1 Res 44/44LL & 58/58LL  
HSW

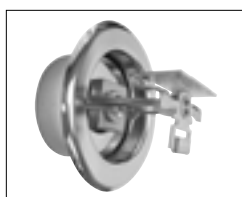

F1 Res 44/44LL  
& 58/58LL  
Recessed HSW/F2



F1 Res 30/30LL,  
49/49LL, 58/58LL & 76  
CCP Pendent



F1 Res 44/44LL  
SWC



RFC 30/30LL,  
43/43LL, 49/49LL



RFC 56



F1 Res 58 HSWX



KRes 58 HSWX

## Table A

### Model F1 Res and Model RFC Residential Sprinklers

Sprinkler Model and Type	Sprinkler Identification Number	Reliable Bulletin Number
F1 Res 30/30LL Pendant F1 Res 30/30LL Recessed Pendant/F1 F1 Res 30/30LL Recessed Pendant/FP F1 Res 30/30LL Recessed Pendant/CCP	R3511 RA3311	135, 033
F1 Res 49/49LL Pendant F1 Res 49/49LL Recessed Pendant/F1 F1 Res 49/49LL Recessed Pendant/FP F1 Res 49/49LL Recessed Pendant/CCP	R3516, RA3316	135, 033
F1 Res 58/58LL Pendant F1 Res 58/58LL Recessed Pendant/F1 F1 Res 58/58LL Recessed Pendant/FP F1 Res 58/58LL Recessed Pendant/CCP	R3513, RA3313	135, 033
RFC 30/30LL, 43/43LL and 49/49LL Recessed Pendant	RA0611, RA0612, RA0616, RA3211, RA3212, RA3216	006, 032
RFC 56 Recessed Pendant	RA0914	009
F1 Res 44/44LL Horizontal Sidewall F1 Res 44/44LL Recessed Horizontal Sidewall	R3531, RA3331	135, 033
F1 Res 44/44LL SWC Recessed Horizontal Sidewall	R3531, RA3331	135,033
F1 Res 58/58LL Horizontal Sidewall F1 Res 58/58LL Recessed Horizontal Sidewall/F2	R3533, RA3335	135, 033
F1 Res 58 HSWX KRes 58 HSWX	R3533, RA3593	135, 176
F1 Res 76 Pendant F1 Res 76 Recessed Pendant/F1 F1 Res 76 Recessed Pendant/FP F1 Res 76 Recessed Pendant/CCP	R7618	135, 176

## General

Reliable residential sprinklers utilize a fast response thermal element and are intended for use in only wet-pipe residential sprinkler systems designed in accordance with the following NFPA standards: NFPA 13D, Installation of Sprinkler Systems for One-and Two-Family Dwellings and Manufactured Homes; NFPA 13R, Installation of Sprinkler Systems in Low-Rise Residential Occupancies and for the residential portions of any occupancy as permitted by NFPA 13, Installation of Sprinkler Systems. Fast response and high wall wetting characteristics of residential sprinklers improve life safety by maintaining a tenable environment, providing escape time for occupants.

NFPA 13D is appropriate for protection against fire hazards only in one-and two-family dwellings and manufactured homes. Residential portions of any other type of building or occupancy should be protected with residential sprinklers in accordance with NFPA 13, or in accordance with NFPA 13R. NFPA 13R is appropriate for use as an option to NFPA 13 only in those residential occupancies up to and including four stories in height. Where buildings are greater than four stories in height, or where buildings are of mixed use where residential is not the predominant occupancy, protect residential portions of such buildings with residential or quick response sprinklers in accordance with NFPA 13.

This document provides design guidelines for the Model F1/Res and RFC Residential Sprinklers shown in Table A, which are cULus Listed to provide a minimum density of 0.05 gpm/ft<sup>2</sup>, in accordance with the above-mentioned standards, manufacturer's instructions and technical bulletins. Where documentation for residential sprinkler systems does not exist for particular applications, information based on NFPA 13 is used.

Residential fire sprinkler systems should only be designed and installed by competent individuals trained and experienced with automatic sprinkler system design and installation. Several criteria may apply to a given installation and the designer and/or installer must be familiar with the applicable codes, standards and guidelines governing such an installation. The Reliable Model F1/Res and RFC residential sprinklers described herein must be installed and maintained in compliance with this document manufacturer's recommendations, with the latest published standards of the National Fire Protection Association (NFPA) and with any additional local jurisdictional requirements. Failure to comply may result in the impairment of sprinkler integrity and proper operation. Because of the various features of residential type architecture, there will be some compartment designs which cannot be fully sprinklered in accordance with the recommendations of NFPA 13, 13D, or 13R. In these instances, consult the Authority Having Jurisdiction for guidance and approval.

The owner is responsible for maintaining their fire protection system and associated devices in proper operating condition. Refer to NFPA 25, Inspection, Testing and Maintenance of Water-Based Fire Protection Systems, for guidance on testing and maintenance of automatic sprinkler systems.

## Approvals

All Reliable residential sprinklers have been designed and tested in accordance with the latest Edition of Underwriters Laboratories (UL) 1626, Standard for Residential Sprinklers for Fire Protection Service. Typically, they are cULus Listed for installation under smooth, flat ceilings of unobstructed construction, unless otherwise noted in the specific listings, with specific approved spacing, flows and pressures. Reliable residential sprinklers are cULus Listed for installation on both horizontal ceilings with a maximum slope of 2/12 (9.4°) pitch and sloped ceilings having maximum slopes of 8/12 (33.7°) pitch. The design criteria for residential sprinklers contained in the current NFPA 13D, 13R and 13 Standards must be followed except as modified by the individual UL 1626 listing information, the information in the Reliable residential sprinkler bulletins and this installation guide. The Authority Having Jurisdiction (AHJ) must make final approval for all residential sprinkler installations for compliance with all applicable codes, standards and jurisdictional requirements.

One of the most important revisions of the Third Edition of UL 1626 is the new minimum density requirement for residential sprinklers manufactured after July 12, 2002. When establishing a minimum cULus Listed flow rate, the manufacturer must use a minimum discharge rate over the specified coverage area corresponding to a 0.05 gpm/ft<sup>2</sup> density. In some cases, however, to successfully pass the UL 1626 fire tests, the UL Listed flow rate may be greater than the calculated 0.05 gpm/ft<sup>2</sup> density. Increased flow rates for horizontal sidewall type sprinklers, which exceed this minimum density, is common. Because this minimum density is a listing requirement, the use of residential sprinklers meeting this criterion is applicable to all editions of NFPA 13, 13R and 13D. The design criteria for residential sprinklers contained in the current NFPA Standards must be followed except as modified by the individual cULus Listing information provided in the technical bulletins referenced in Table A.

## Definitions

The following NFPA definitions are applicable to the terms used in this installation guide. Where terms are not included, refer to NFPA 13, NFPA 13D and NFPA 13R for official definitions:

Residential Sprinkler – A type of fast-response sprinkler that has a thermal element with an RTI of 50 (m-s)<sup>1/2</sup> or less, has been specifically tested for its ability to enhance survivability in the room of fire origin and listed for use in the protection of dwelling units. Residential sprinklers possess a fast response thermal element and produce a spray pattern that discharges water higher on the wall than a standard spray sprinkler.

Dwelling – Any building that contains not more than one or two dwelling units intended to be used, rented, leased, let or hired out to be occupied or that are occupied for habitation purposes.

Dwelling Unit – One or more rooms, arranged for the use of one or more individuals living together, as in a single housekeeping unit, that normally have cooking, living, sanitary and sleeping facilities. Dwelling units include hotel rooms, dormitory rooms, condominiums, apartments and similar living units.

Compartment – A compartment is a space completely enclosed by walls and a ceiling. The compartment enclosure is permitted to have openings (in walls) to an adjoining space, provided that soffits or lintels along the ceiling over the compartment opening has a minimum depth of 8 in. (203 mm) from the ceiling. In other words, areas such as hallways, stairwells and rooms must be separated by beams, lintels or soffits 8 or more inches in depth to be considered single compartments.

Obstructed Construction – Panel construction and other construction where beams, trusses, or other members impede heat flow or water distribution in a manner that materially affects the ability of sprinklers to control or suppress a fire. See NFPA 13 Appendix for detailed explanations of this type of construction.

Unobstructed Construction – Construction where beams, trusses, or other members do not impede heat flow or water distribution in a manner that materially affects the ability of sprinklers to control or suppress a fire. This type of construction has the following features: (1) horizontal structural members that are not solid; (2) openings of the structural members are at least 70% of the cross sectional area; (3) depth of the structural members do not exceed the least dimension of the openings; or (4) the spacing of structural members exceeds 7.5 feet on center. See NFPA 13 Appendix for detailed explanations of this type of construction.

Flat Ceiling – a continuous ceiling in a single plane.

Smooth Ceiling – A continuous ceiling free from significant irregularities, lumps or indentations.

Horizontal Ceiling – A ceiling that does not exceed a slope of 2/12 pitch (slope of 16.7% or 9.4°).

Sloped Ceiling – A ceiling exceeding a maximum slope of 2/12 (9.4°) pitch.

## Installation Considerations

Residential sprinklers utilizing a glass bulb thermal element have orange protective caps and straps to provide temporary protection to the frangible glass bulb during shipping and installation.

- a. Do not install any bulb type sprinkler if the bulb is cracked or there is liquid missing from the bulb. While holding the sprinkler in the horizontal position, a small air bubble having an approximate diameter of 1/16" should be visible.
- b. The sprinkler is designed for installation with the protective strap in place using the appropriate sprinkler wrench.
- c. Sprinklers that are dropped during the installation process or that are installed on piping other than that in accordance with item "a" shall be replaced, including sprinklers with protective caps or straps.
- d. Protective caps and straps shall be removed only using means in accordance with the manufacturer's installation instructions. They are not to be left on the sprinkler after the sprinkler system is placed in service.
- e. Protective caps and straps shall be removed only when water supply is made available to the sprinkler for the purposes of fire protection and placed in service.
- f. A leak-tight 1/2" NPT sprinkler joint should be obtained with a maximum torque of 14 ft-lb to 21 ft-lb (approximately 2 turns past hand tight. Do not over tighten). Higher levels of torque may distort the sprinkler inlet or bend the frame, causing leakage or impairment of the sprinkler.

Where applicable, escutcheon plates must be installed. Absence of an escutcheon plate, where there is an annular space between the ceiling and the sprinkler, may delay sprinkler operation in the event of a fire.

Never introduce any leak stopping additives to any fire sprinkler system.

Residential sprinklers must be installed with the manufacturer's specified sprinkler wrench. Channel locks, crescent wrenches or anything other than the proper sprinkler wrench shall not be used.

Installing sprinklers in CPVC and copper piping systems require special considerations. Never install the sprinkler into the reducing fitting prior to attaching the reducing fitting to the system piping. When installing residential sprinklers or commercial sprinklers in a CPVC piping system, sprinklers must be installed only after the reducing fitting has been installed and the CPVC manufacturer's setting time for the primer and/or cement has passed. This is to ensure that the cement does not accumulate within the sprinkler. In copper piping systems, sprinklers must be installed only after the inside of the sprinkler drop and associated fittings have been wire-brushed to remove any residual flux. Residual flux can cause corrosion. Both of these conditions can impair and prevent proper sprinkler operation.

## System Design Criteria

### Permitted Sprinklers for Residential Sprinkler Systems

For NFPA 13D and 13R sprinkler systems, only listed residential sprinklers shall be used, with the following exceptions:

1. Listed standard dry-pendent or dry sidewall sprinklers shall be permitted to be extended into unheated areas not intended for living purposes.
2. Quick-response sprinklers shall be permitted to be used in mechanical closets.
3. For NFPA 13R systems, listed quick-response sprinklers shall be permitted to be installed in dwelling units meeting the definition of a compartment where no more than four (4) sprinklers are located within the dwelling unit.

Non-residential sprinklers are to be installed in accordance with the criteria specified by NFPA 13.

### Residential Sprinkler Positioning and Spacing Requirements

When locating residential sprinklers, consideration must be given to sensitivity, sprinkler spacing, obstructions to discharge, temperature rating and proximity to heat sources.

#### Sprinkler Sensitivity - Deflector Positioning

Residential pendent sprinklers not listed with specific positioning criteria must be positioned so that the deflectors are within 1 in. to 4 in. (25.4 mm to 102 mm) from the ceiling. On flat, horizontal ceilings, Reliable Model F1 Res 49 pendent and recessed pendent sprinklers may also be positioned with the deflector 4" to 8" (102 mm to 203 mm) from the ceiling, in accordance with the listed flows and pressures shown in Bulletin 135. If located in closets, it is permitted to install pendent sprinklers so that the deflector is within 12 inches (305 mm) of the ceiling. Residential sidewall sprinklers that have not been listed with specific positioning criteria must be positioned so that the deflectors are within 4 in. to 6 in. (102 mm to 152 mm) from the ceiling. Install sidewall sprinklers having listed positioning criteria in accordance with their listing. Under both horizontal and sloped ceilings, always align sprinkler deflectors so that the deflector is parallel with the plane of the ceiling surface.

#### Sprinkler Spacing Under Horizontal Ceilings

Several maximum coverage areas are used for residential sprinklers in accordance with minimum listed flows and pressures. The area of coverage must be equal to or greater than both the length and width of the hazard area. Residential sprinklers must be located not more than half the listed spacing nor less than 4" (102 mm) from walls. Adjacent sprinklers must be located no farther apart than the listed spacing; the minimum distance to prevent cold soldering, unless otherwise specified, is 8 feet (2.44 m).

When selecting an area of coverage, the suggested practice is to select one that can be adequately supplied by the available water supply, allowing for the installation of as few sprinklers as possible while observing all guidelines pertaining to obstructions and spacing. After selection of an area of coverage, sprinklers must be spaced according to the criteria set forth in the NFPA standards and this document.

#### Sprinkler Spacing Under Sloped Ceilings

The spacing of sprinklers is measured along the slope when determining the distance off of walls and between sprinklers. Residential sprinklers may be located no more than 1/2 the listed spacing nor less than 4" (102 mm) from the peak of the sloped ceiling. Residential sprinklers located at the highest elevation must not be located more than 3 feet (0.9 m) measured vertically down from the peak.

#### Obstruction to Water Distribution

Refer to Figures 1 through 13 for the location of sprinklers relative to obstructions. The discharge from residential sprinklers is directed radially outward and downward from the sprinkler. Sprinklers must be located such that there will not be any spaces shielded from distribution by walls, dividing partitions, or other dwelling construction features. If the sprinkler water distribution pattern is obstructed, the obstruction is to be considered the maximum distance of coverage for a given sprinkler. Additional sprinklers beyond the obstruction may be necessary unless the obstruction criteria contained herein can be met. Consult the appropriate NFPA standard and/or the AHJ for guidance regarding these situations.

Reliable flat plate concealed sprinklers, the Models RFC30 (30LL), RFC43 (43LL), RFC49 (49LL) and RFC56, utilize a drop-down style deflector. The distance the deflector drops below the ceiling is needed when determining the position of the deflector above the bottom of an obstruction. These distance are as follows:

- Nonadjusted (cover plate flush to cup) - 7/8" (22 mm)
- At full (1/2") adjustment - 3/8" (9.5 mm)

## Continuous and Noncontinuous Obstructions

A minimum distance is required to be maintained between sprinklers and continuous obstructions, such as beams, soffits and long horizontal light fixtures. See Figures 1, 2, 4, 5, 6, 7 and/ or 13.

A minimum distance is also required to be maintained between sprinklers and noncontinuous obstructions, such as ceiling fans and certain light fixtures. The ceiling fan motor housing is the primary element that can obstruct the sprinkler discharge pattern. Testing has demonstrated that no adverse effects occur as a result of the ceiling fan's blade rotation in either direction.

With regards to location of sprinklers near light fixtures, there are two considerations; the amount of heat the light gives off and the light fixture as an obstruction. The minimum distance of a sprinkler relative to the light as a heat source is given in Table B. If the light is also an obstruction, then the obstruction criteria must be applied, relative to the minimum distance required from Table B.

For noncontinuous obstructions, apply the "four times rule" as provided in NFPA 13 where it is determined that the sprinkler can spray to at least two sides of the obstruction, either over and under or around the obstruction on both sides. Sprinklers shall be positioned away from the obstruction a minimum distance of four times the maximum dimension of the obstruction. The maximum clear distance required shall be 36" (914 mm).

## Temperature Ratings

Ordinary temperature rated sprinklers (135 °F [57 °C], 155 °F [57 °C]) are only permitted for installation where the maximum ambient ceiling temperature will not exceed 100 °F (38 °C). Where ambient ceiling temperatures are expected to exceed 100 °F (38 °C), use intermediate temperature-rated residential sprinklers (175 °F [79 °C]), which can be exposed to a maximum ambient temperature of 150 °F (66 °C). The following practices apply, unless higher expected ambient temperatures require a higher temperature rated sprinkler:

1. Sprinklers under glass or plastic skylights exposed to direct rays of the sun shall be of the intermediate temperature classification.
2. Sprinklers in an unventilated concealed space under insulated roof or in an unventilated attic shall be of the intermediate temperature classification.
3. Residential sprinklers must be located so as to prevent inadvertent operation due to exposure to normal heat sources. Sprinklers must be positioned a sufficient distance away from heat sources such as fireplaces, ovens, kitchen ranges, hot water pipes, water heaters, furnaces and associated duct work and light fixtures. The following minimum distances in accordance with NFPA 13D and 13R must be maintained as indicated in Table B.

**Table B**

**Minimum Distances for Ordinary and Intermediate Residential Sprinklers Relative to Specific Heat Sources**

Heat Source	Minimum Distance from Edge of Source to Ordinary Temperature Sprinkler (135 °F or 155 °F)		Minimum Distance from Edge of Source to Intermediate Temperature Sprinkler (175 °F)	
	inch	mm	inch	mm
Side of open or Recessed fireplace	36	914	12	305
Front of recessed fireplace	60	1524	36	914
Coal or wood-burning stove	42	1067	12	305
Kitchen range	18	457	9	229
Wall oven	18	457	9	229
Hot air flues	18	457	9	229
Uninsulated heat ducts	18	457	9	229
Uninsulated hot water pipes	12	305	6	152
Side of ceiling or wall-mounted hot air diffusers	24	607	12	305
Front of wall-mounted hot air diffusers	36	914	18	457
Hot water heater or furnace	6	152	3	76
Light Fixture 0 W – 250 W 250 W – 499 W	6 12	152 305	3 6	76 152

## Hydraulic Design Requirements

Reliable residential sprinkler listings indicate minimum flow rates for each specified coverage area. Hydraulic calculations are required to verify adequate water supply at the hydraulically most remote single sprinkler operating at the minimum flow and pressure listed for single sprinkler operation. Where a compartment has more than one sprinkler, multiple sprinkler calculations are required and each sprinkler within the design area must be calculated using the flow rates corresponding to its area of coverage. No reduction in minimum flow requirements is provided for flowing multiple sprinklers. More design sprinklers may need to be calculated than the minimum stated by the NFPA standards where unusual conditions may result in more sprinklers operating. These conditions include sloped ceilings having a pitch greater than 8/12 (33.7°) ceiling heights over 24' and/or beamed ceilings greater than 600 SF in area. Consult with the AHJ regarding the number of "design sprinklers" for these types of applications.

### NFPA 13D

The number of design sprinklers under flat, smooth, horizontal ceilings shall include all sprinklers within a compartment, up to a maximum of two (2) sprinklers, that requires the greatest hydraulic demand. The cULus Listed specific coverage criteria for systems designed to NFPA 13R are given in the technical bulletins referenced in Table A, as a function of the maximum allowable coverage area and temperature rating. For actual coverage areas less than or between those indicated in the respective bulletin, it is necessary to use the minimum required flow for the next largest area, as shown above.

For example, assuming the use of a pendent sprinkler, for an actual coverage area of 12 ft x 14 ft (3.7 m x 4.2 m), the specific coverage criteria for a 14 ft x 14 ft (4.2 m x 4.2 m) coverage area must be used. For an actual coverage area of 15 ft x 15 ft (4.6 m x 4.6 m), the specific coverage criteria for a 16 ft x 16 ft (4.9 m x 4.9 m) coverage area must be used.

### NFPA 13R

The number of design sprinklers under flat, smooth, horizontal ceilings shall include all sprinklers within a compartment, up to a maximum of four (4) sprinklers, that requires the greatest hydraulic demand. The cULus Listed specific coverage criteria for systems designed to NFPA 13R are given in the technical bulletins referenced in Table A, as a function of the maximum allowable coverage area and temperature rating. For actual coverage areas less than or between those indicated in the respective bulletin, it is necessary to use the minimum required flow for the next largest area, as shown above.

### NFPA 13

For residential sprinkler systems designed to NFPA 13, a minimum density of 0.1 gpm/ft<sup>2</sup> must be provided over the "design area" that includes the four (4) hydraulically most demanding sprinklers for the actual coverage areas being protected by the 4 sprinklers. The minimum required discharge from each of the four most hydraulically demanding sprinklers shall be the **greater** of the following:

1. The flow rates given in the Reliable Residential Sprinkler Technical Bulletins referenced in Table A for NFPA 13D and 13R as a function of temperature rating and maximum allowable coverage area (for actual coverage areas less than or between those indicated in the respective technical bulletin, it is required to use the minimum required flow for the next largest coverage area); or
2. A minimum discharge density of 0.1 gpm/ft<sup>2</sup> applied over the "design area" consisting of the four most hydraulically demanding sprinklers for the actual coverage areas being protected by the four sprinklers. The maximum dimension of the actual coverage area cannot be any greater than the maximum coverage area indicated in the technical bulletins referenced in Table A.

**Design Note:** Using the  $A_s = S \times L$  method to determine the sprinkler protection area of coverage in accordance with NFPA 13, apply the 0.1 gpm/ft<sup>2</sup> density to this area to determine the minimum required flow. Compare this flow to the minimum 0.05 gpm/ft<sup>2</sup> cULus Listed flow for the appropriate coverage area in the technical bulletin for the specific residential sprinkler. If the flow stated in the technical bulletin is less than the calculated 0.1 gpm/ft<sup>2</sup> density flow required, the .1 density flow must then be used in the equation  $Q=K\sqrt{P}$ , solving for P, to establish the minimum required pressure using the sprinkler K-factor.

**Note:** In many cases the listed flow of individual residential sprinklers may exceed the required minimum 0.05 gpm/ft<sup>2</sup> density. Reliable has available residential sprinklers with larger K-factors (K=5.6 and K=5.8) that will provide lower pressure demands for 0.1 gpm/ft<sup>2</sup> densities in NFPA 13 residential applications.

#### Example No. 1

If a room is 12 ft wide x 20 ft long (3.6 m x 6.1 m), the coverage area being considered would be 240 ft<sup>2</sup> (22.3 m<sup>2</sup>). Using an F1 Res 49 pendent sprinkler (1"-4" ceiling-to-deflector distance), the flow for a 20 ft x 20 ft (6.1 m x 6.1 m) coverage area is 20 gpm @ 16.7 psi (75.7 l/min @ 1.14 bar). However, based on a discharge density of 0.1 gpm/ft<sup>2</sup>, the flow rate required would be 24 gpm (90.8 L). Therefore, 24 gpm (90.8 l/min) would be the minimum flow required for each design sprinkler. The corresponding pressure would be 24 psi (1.65 bar)

**Example No. 2**

If a room is 10 ft wide x 20 ft long (3.0 m x 6.1 m), the coverage area being considered would be 200 ft<sup>2</sup> (18.6 m<sup>2</sup>). Using an F1 Res 58 pendent sprinkler (1"-4" ceiling-to-deflector distance), the flow for a 20 ft x 20 ft (6.1 m x 6.1 m) coverage area is 22 gpm @ 14.4 psi (83.3 l/min @ 0.99 bar). Based on a discharge density of 0.1 gpm/ft<sup>2</sup>, the flow rate required would only be 20 gpm (75.7 l/min). However, the flow of 22 gpm must still be used as the minimum flow for each design sprinkler, since this is the minimum cULus Listed flow for this sprinkler at the 20 ft x 20 ft coverage area.

**Example No. 3**

For a situation where the coverage area per sprinkler is 16 ft x 8 ft (4.9 m x 2.4 m), or 128 ft<sup>2</sup> (11.9 m<sup>2</sup>), the F1 RES 44 HSW, having a temperature rating of 155 °F (68 °C) and positioned 4" to 6" (101 mm to 152 mm) below the ceiling, requires a minimum flow of 16 gpm @ 13.3 psi (60.6 l/min @ .92 bar) for a 16 ft x 16 ft (4.9 m x 4.9 m) coverage area. Based on a minimum discharge of 0.1 gpm/ft<sup>2</sup>, the flow rate needed would only be 12.8 gpm @ 10.2 psi (48.4 l/min @ 0.7 bar). However, the flow rate of 16 gpm (60.6 l/min) must still be used for each design sprinkler.

**Sloped Ceilings**

Listed areas of coverage are applicable for sloped ceilings up to an 8/12 pitch (33.7°). Spacing of sprinklers under sloped ceilings is measured along the slope when determining distance off of walls and between sprinklers.

**Unusual Conditions**

Listed flows and pressures do not exist for sloped ceilings having a pitch greater than 8/12 (33.7°), ceiling heights over 24' and/or rooms over 600 SF having beamed ceilings. Consult with the AHJ regarding the number of "design sprinklers" for these types of applications.

**Care and Maintenance**

It is recommended that automatic sprinkler systems be inspected and maintained in accordance with the criteria set forth in NFPA 25, Inspection, Testing and Maintenance of Water-Based Fire Protection Systems by a qualified inspection service.

Do not clean the sprinklers with soap and water, detergents, ammonia, or any other cleaning fluid. Remove dust by using a soft brush or feather duster, or by gentle vacuuming with a soft bristle brush.

Any sprinklers that have operated, been damaged or been painted outside of the factory shall be replaced with a new sprinkler. The new sprinkler shall have the same performance characteristics as the original sprinkler; that is the same temperature rating, nominal K-factor, coverage area and the same or lower flow rate requirements.

Wet-pipe sprinkler systems must be maintained at a minimum temperature of 40 °F (4 °C). Exposure to freezing temperatures can damage system piping and residential sprinklers.

Do not hang anything from sprinklers or sprinkler piping. Do not put curtains, drapes or valences around sprinklers. Doing so will obstruct the discharge pattern of the sprinkler.

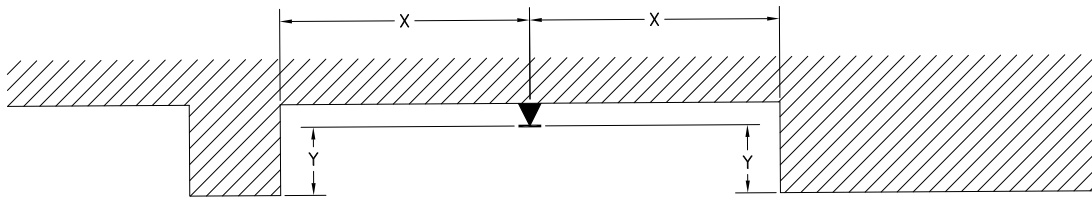

**ELEVATION**

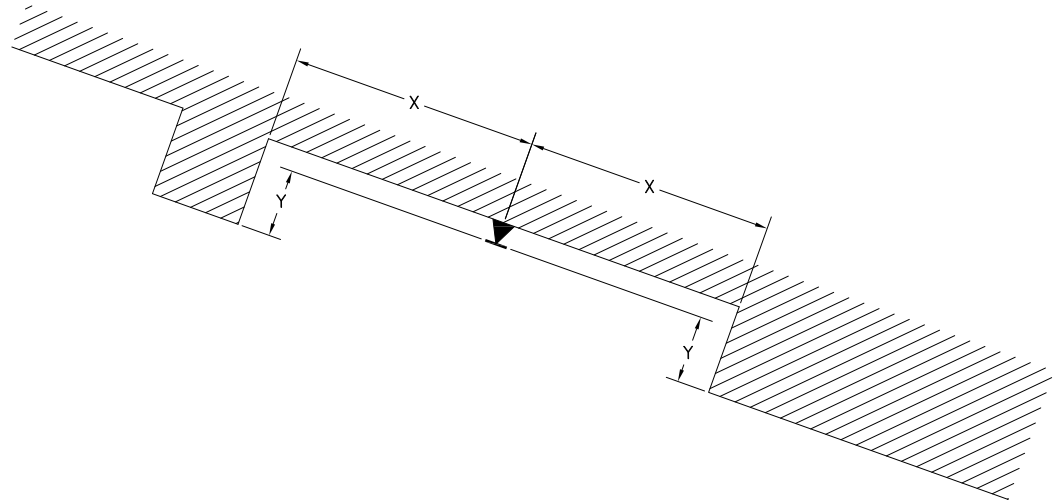

**DISTANCE FROM SPRINKLERS TO SIDE OF OBSTRUCTION (X)**

**MAXIMUM ALLOWABLE DISTANCE OF DEFLECTOR ABOVE BOTTOM OF OBSTRUCTION (Y)**

LESS THAN 1' 0" (304.8 mm)	0"
1' 0" (308.8 mm) TO LESS THAN 1' 6" (457.2 mm)	0"
1' 6" (457.2 mm) TO LESS THAN 2' 0" (609.6 mm)	1" (25.4 mm)
2' 0" (609.6 mm) TO LESS THAN 2' 6" (762 mm)	1" (25.4 mm)
2' 6" (762 mm) TO LESS THAN 3' 0" (914 mm)	1" (25.4 mm)
3' 0" (914 mm) TO LESS THAN 3' 6" (1016 mm)	3" (76.2 mm)
3' 6" (1016 mm) TO LESS THAN 4' 0" (1219.2 mm)	3" (76.2 mm)
4' 0" (1219.2 mm) TO LESS THAN 4' 6" (1371.6 mm)	5" (127 mm)
4' 6" (1371.6 mm) TO LESS THAN 5' 0" (1524 mm)	7" (177.8 mm)
5' 0" (1524 mm) TO LESS THAN 5' 6" (1676.4 mm)	7" (177.8 mm)
5' 6" (1676.4 mm) TO LESS THAN 6' 0" (1828.8 mm)	7" (177.8 mm)
6' 0" (1828.8 mm) TO LESS THAN 6' 6" (1981.2 mm)	9" (228.6 mm)
6' 6" (1981.2 mm) TO LESS THAN 7' 0" (2133.6 mm)	11" (279.4 mm)
7' 0" (2133.6 mm) AND GREATER	14" (355.6 mm)

Figure 1 – Position of sprinklers to avoid obstructions to discharge radially from pendent sprinklers.



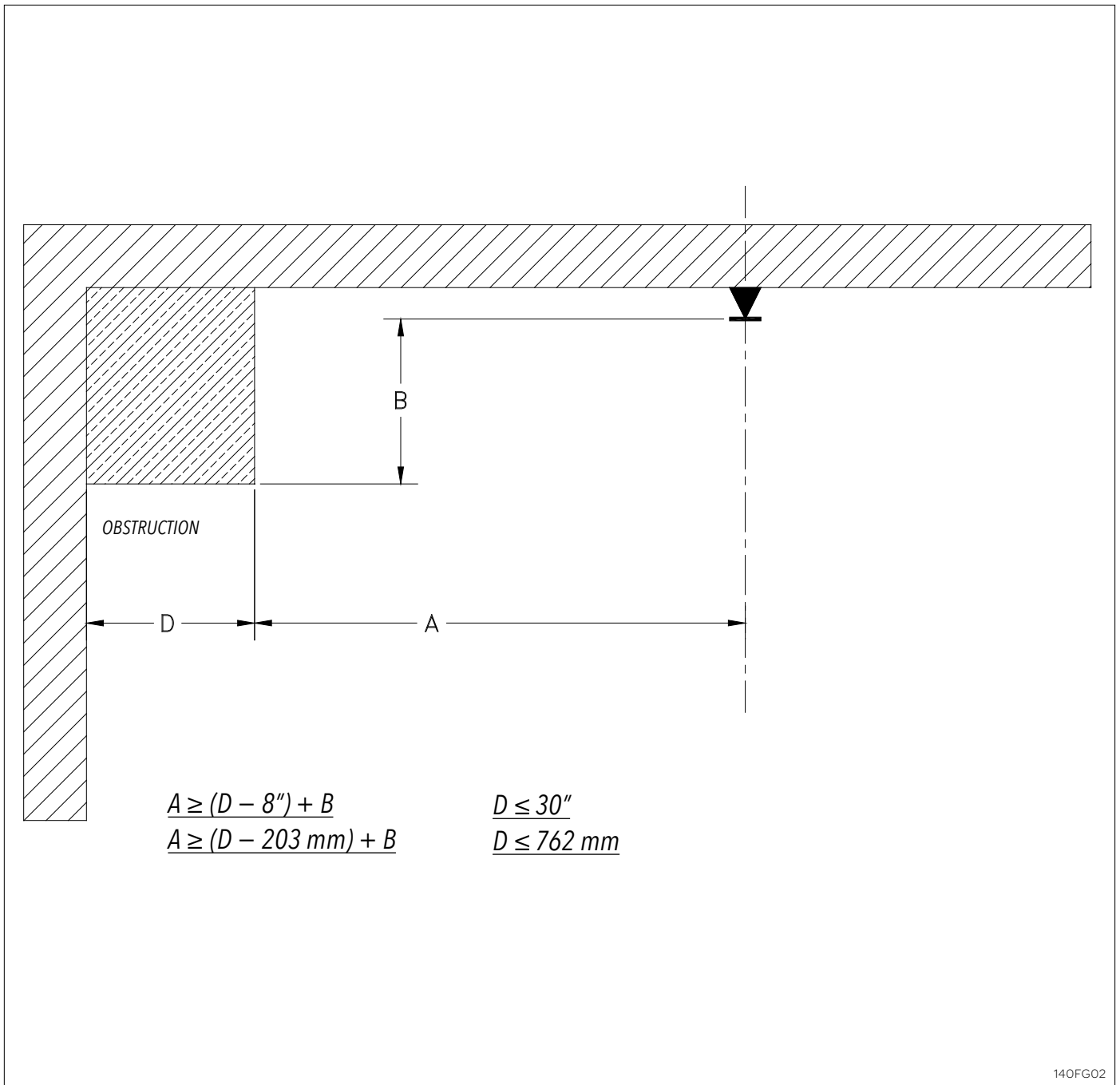

140FG02

Figure 2 – Positioning of pendent type sprinklers relative to obstructions against walls.

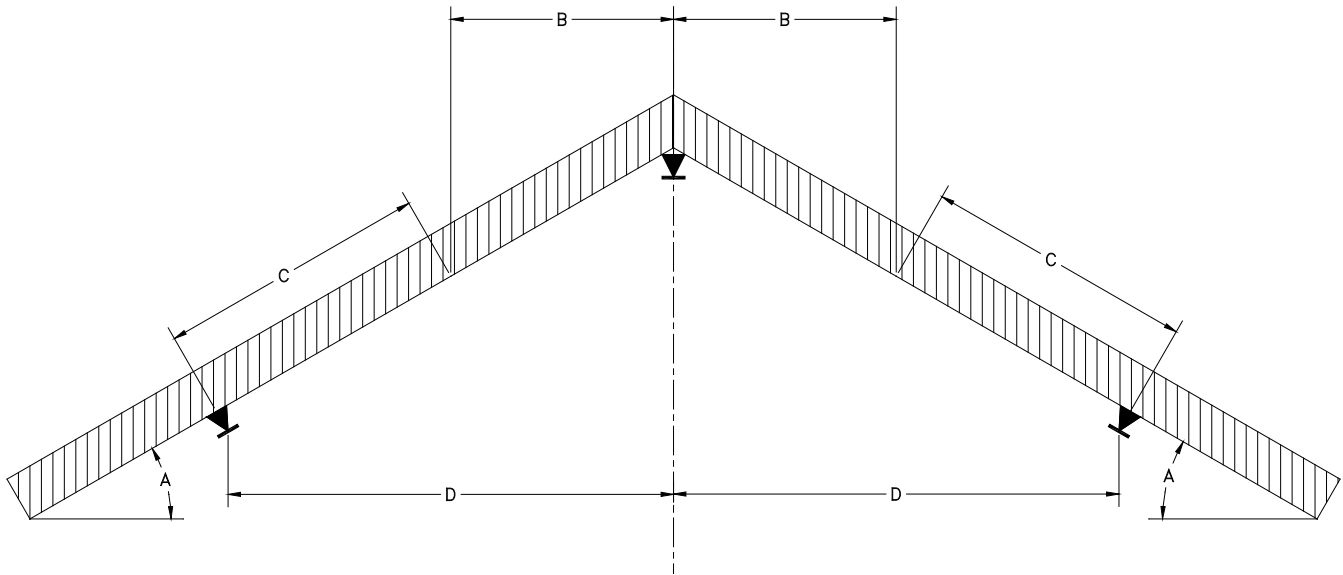

A - ACCEPTABLE CEILING ANGLE 10° - 33.7°

B - UP TO ONE-HALF THE MAXIMUM SPRINKLER SPACING (SEE TECHNICAL BULLETINS REFERENCED IN TABLE A) FOR THE COVERAGE AREA, MEASURED ALONG THE SLOPE, OR AS RESTRICTED BY THE TABLE BELOW)

<u>CEILING ANGLE (A)</u>	<u>MAXIMUM PERMITTED HORIZONTAL DISTANCE (B)</u>
10°	10' 0" (3048 mm)
12°	9' 10" (2997.2 mm)
15°	9' 6" (2895.6 mm)
18°	9' 2" (2784 mm)
20°	9' 0" (2743.2 mm)
22°	8' 6" (2598.8 mm)
25°	8' 0" (2438.4 mm)
28°	7' 4" (2235.2 mm)
30°	7' 0" (2133.6 mm)
33.7°	6' 2" (1879.6 mm)

C - ONE-HALF THE MAXIMUM SPRINKLER SPACING FOR THE COVERAGE AREA, MEASURED ALONG THE SLOPE.

D - MINIMUM 8' 0" (2438.4 mm)

Figure 3 – Sprinkler spacing for pendent sprinklers located at the peak.

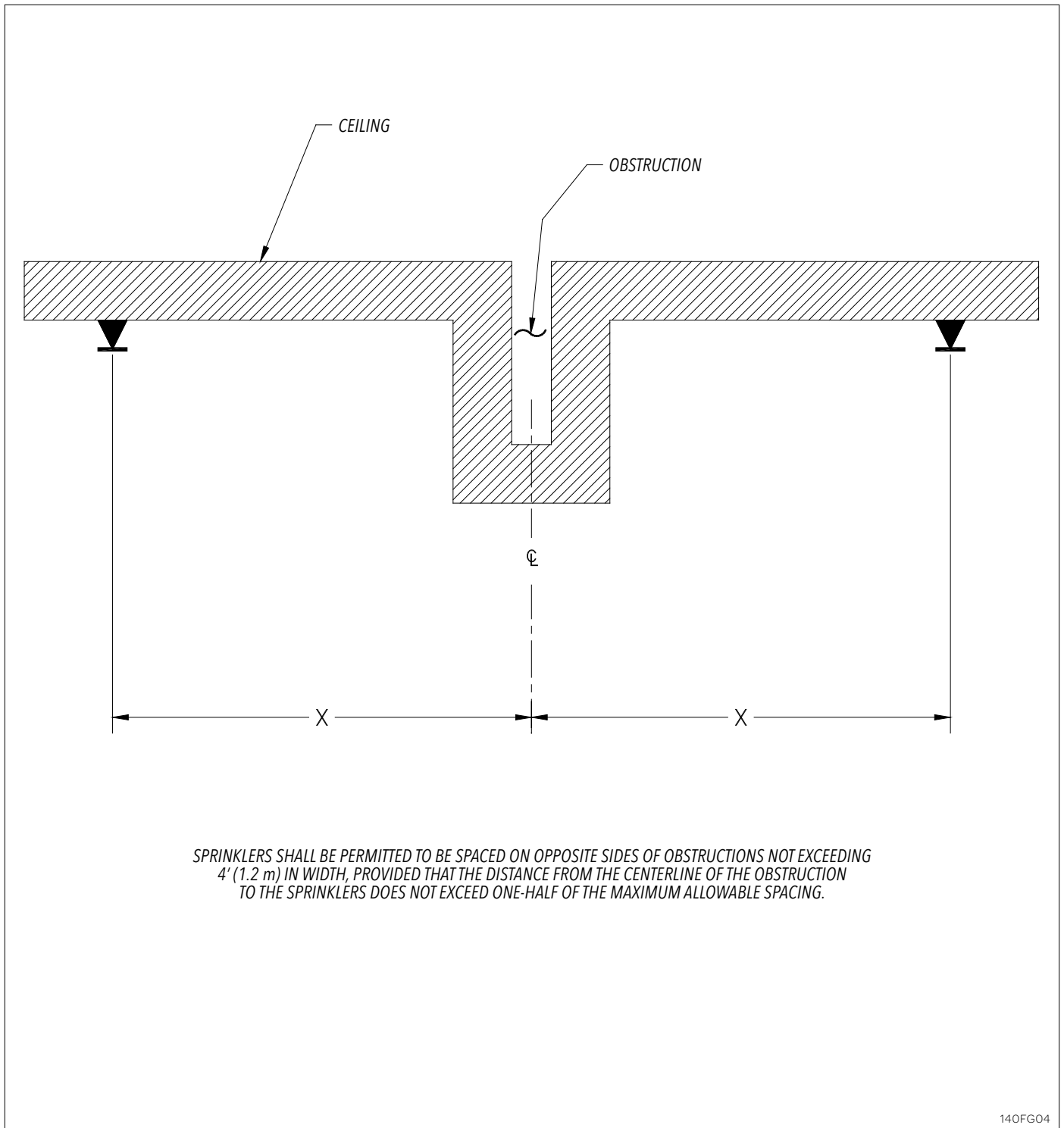
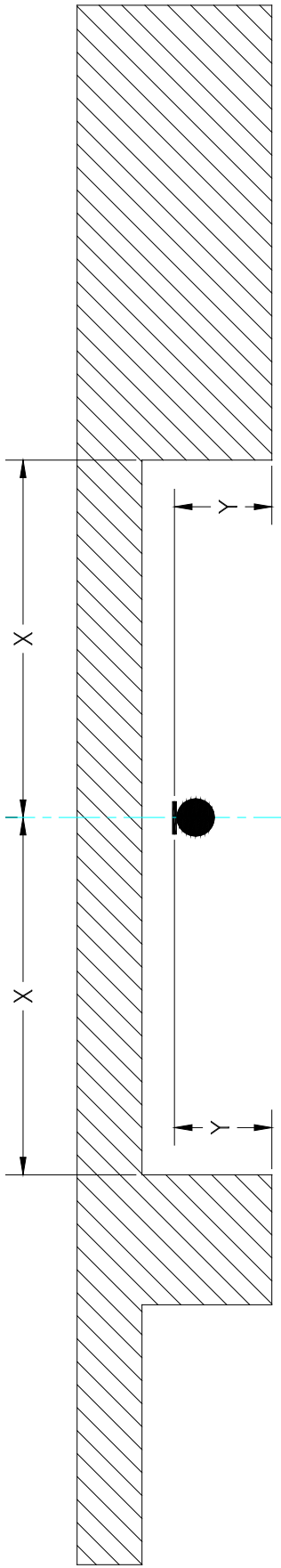

Figure 4 – Positioning of pendent sprinklers relative to continuous obstructions at the ceiling.



**DISTANCE FROM SIDEWALL SPRINKLER TO SIDE OF OBSTRUCTION (X)**

**MAXIMUM ALLOWABLE DISTANCE OF DEFLECTOR ABOVE BOTTOM OF OBSTRUCTION (Y)**

LESS THAN 1' 6" (508 mm)	NOT ALLOWED
1' 6" (508 mm) TO LESS THAN 3' 0" (914 mm)	1" (25.4 mm)
3' 0" (914 mm) TO LESS THAN 3' 6" (1016 mm)	1" (25.4 mm)
3' 6" (1016 mm) TO LESS THAN 4' 0" (1219.2 mm)	3" (76.2 mm)
4' 0" (1219.2 mm) TO LESS THAN 4' 6" (1371.6 mm)	4" (101.6 mm)
4' 6" (1371.6 mm) TO LESS THAN 5' 0" (1524 mm)	5" (127 mm)
5' 0" (1524 mm) TO LESS THAN 5' 6" (1676.4 mm)	6" (152.4 mm)
5' 6" (1676.4 mm) TO LESS THAN 6' 0" (1828.8 mm)	7" (177.8 mm)
6' 0" (1828.8 mm) TO LESS THAN 6' 6" (1981.2 mm)	9" (228.6 mm)
6' 6" (1981.2 mm) TO LESS THAN 7' 0" (2133.6 mm)	11" (279.4 mm)
7' 0" (2133.6 mm) TO 8' 0"	14" (355.6 mm)

Figure 5 – Positioning of sidewall sprinklers to avoid obstructions along the wall.

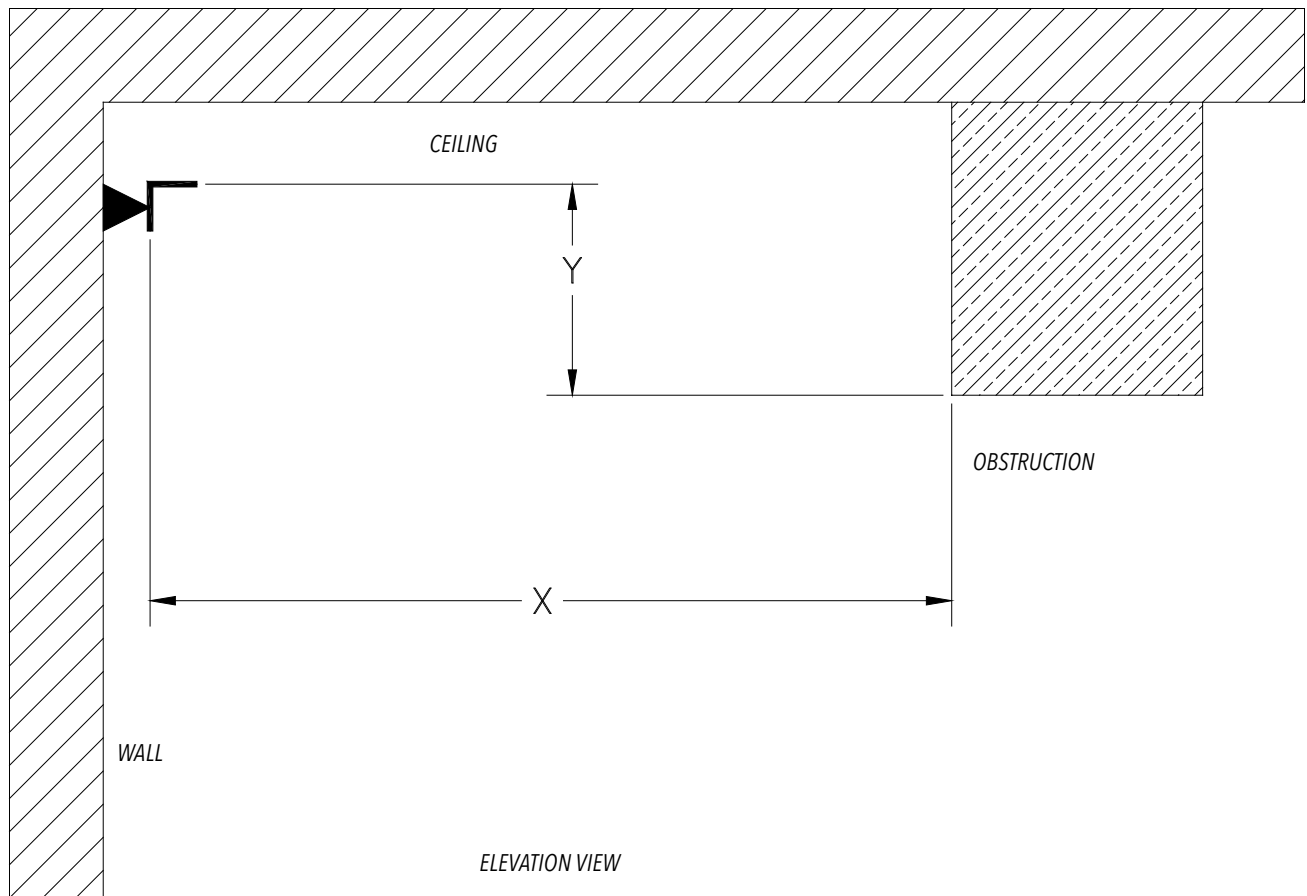

**DISTANCE FROM SIDEWALL SPRINKLER TO SIDE OF OBSTRUCTION (X)**

**MAXIMUM ALLOWABLE DISTANCE OF DEFLECTOR ABOVE BOTTOM OF OBSTRUCTION (Y)**

<i>LESS THAN 8' 0" (2438.4 mm)</i>	<i>NOT ALLOWED</i>
<i>8' 0" (2438.4 mm) TO LESS THAN 10' 0" (3048 mm)</i>	<i>1" (25.4 mm)</i>
<i>10' 0" (3048 mm) TO LESS THAN 11' 0" (3352 mm)</i>	<i>2" (50.8 mm)</i>
<i>11' 0" (3352 mm) TO LESS THAN 12' 0" (3657.6 mm)</i>	<i>3" (76.2 mm)</i>
<i>12' 0" (3657.6 mm) TO LESS THAN 13' 0" (3962.4 mm)</i>	<i>4" (101.6 mm)</i>
<i>13' 0" (3962.4 mm) TO LESS THAN 14' 0" (4267.2 mm)</i>	<i>6" (152.4 mm)</i>
<i>14' 0" (4267.2 mm) TO LESS THAN 15' 0" (4572 mm)</i>	<i>7" (177.8 mm)</i>
<i>15' 0" (4572 mm) TO LESS THAN 16' 0" (4876.6 mm)</i>	<i>9" (228.6 mm)</i>
<i>16' 0" (4876.6 mm) TO LESS THAN 17' 0" (5181.6 mm)</i>	<i>11" (279.4 mm)</i>
<i>17' 0" (5181.6 mm) OR GREATER</i>	<i>14" (355.6 mm)</i>

Figure 6 – Positioning of sidewall sprinklers to avoid obstructions.

HORIZONTAL SIDEWALL SPRINKLER INSTALLED BELOW SOFFITS

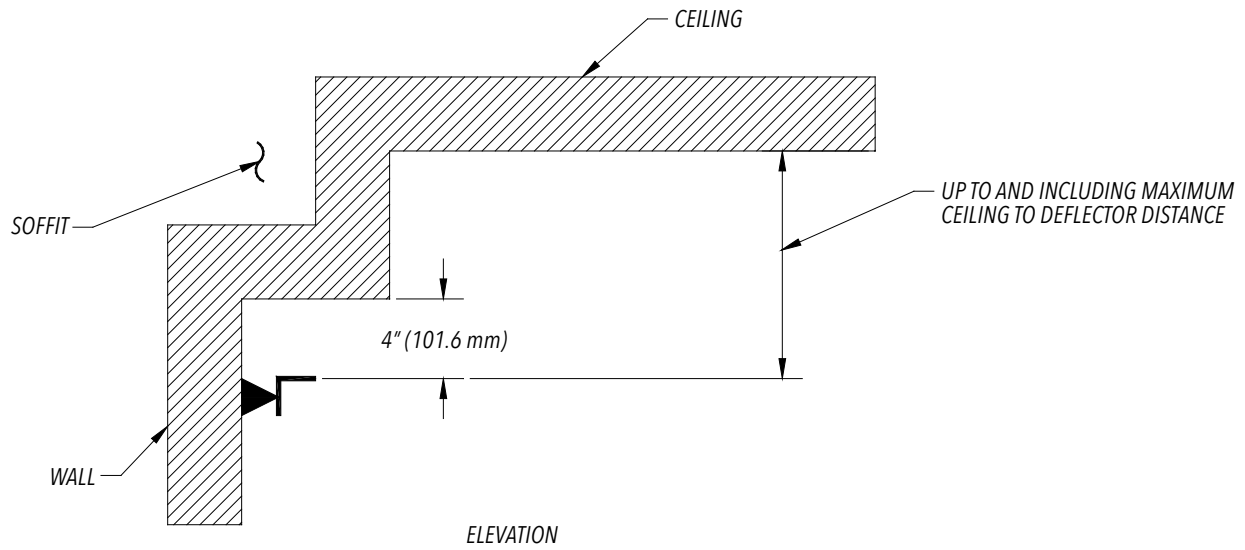

HORIZONTAL SIDEWALL SPRINKLER INSTALLED ON SIDE OF THE SOFFITS

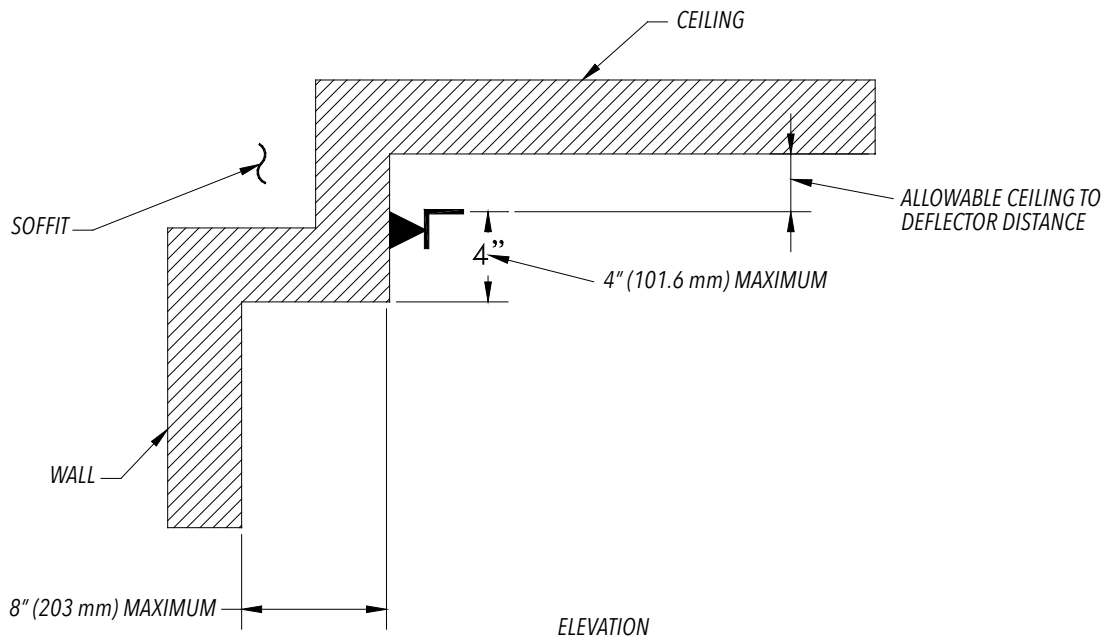
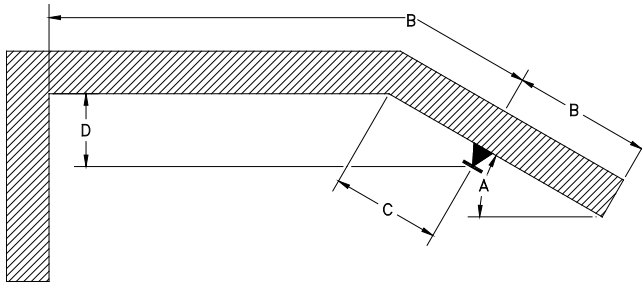
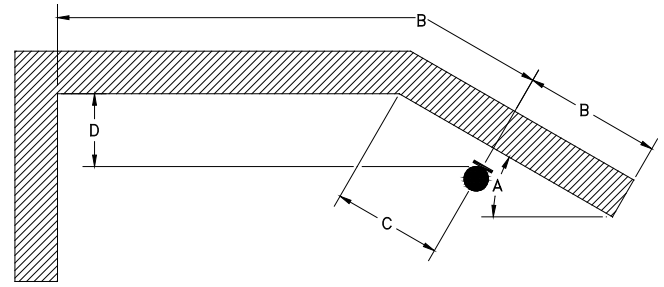

Figure 7 – Positioning of HSW sprinklers relative to continuous obstructions along a wall.



**PENDENT SPRINKLER ELEVATION**



**SIDEWALL SPRINKLER ELEVATION**

A – ACCEPTABLE CEILING ANGLE 10° - 33.7°

B – UP TO ONE-HALF THE MAXIMUM LISTED SPRINKLER SPACING (SEE TECHNICAL BULLETINS REFERENCED IN TABLE A) FOR THE COVERAGE AREA, MEASURED ALONG THE SLOPE.

C – MAXIMUM DISTANCE TO INTERSECTING HORIZONTAL CEILING

D – MINIMUM 3' 0"

<u>CEILING ANGLE (A)</u>	<u>SPRINKLER SPACING (FT.)</u>	<u>MINIMUM SLOPED DISTANCE (C)</u>
10° 0"	12' 0" (3657.4 mm)	0' 6" (152.4 mm)
	14' 0" (4267.2 mm)	0' 6" (152.4 mm)
	16' 0" (4876.6 mm)	0' 6" (152.4 mm)
	18' 0" (5486.4 mm)	0' 10" (254 mm)
	20' 0" (6096 mm)	1' 0" (304.8 mm)
15° 0"	12' 0" (3657.4 mm)	0' 6" (152.4 mm)
	14' 0" (4267.2 mm)	0' 6" (152.4 mm)
	16' 0" (4876.6 mm)	0' 6" (152.4 mm)
	18' 0" (5486.4 mm)	1' 4" (406.4 mm)
	20' 0" (6096 mm)	2' 2" (660.4 mm)
18° 4"	12' 0" (3657.4 mm)	0' 6" (152.4 mm)
	14' 0" (4267.2 mm)	0' 6" (152.4 mm)
	16' 0" (4876.6 mm)	0' 6" (152.4 mm)
	18' 0" (5486.4 mm)	2' 2" (660.4 mm)
	20' 0" (6096 mm)	3' 0" (914.4 mm)
20° 0"	12' 0" (3657.4 mm)	0' 6" (152.4 mm)
	14' 0" (4267.2 mm)	0' 6" (152.4 mm)
	16' 0" (4876.6 mm)	0' 6" (152.4 mm)
	18' 0" (5486.4 mm)	2' 8" (812.8 mm)
	20' 0" (6096 mm)	3' 8" (1117.6 mm)
25° 0"	12' 0" (3657.4 mm)	0' 6" (152.4 mm)
	14' 0" (4267.2 mm)	0' 6" (152.4 mm)
	16' 0" (4876.6 mm)	0' 6" (152.4 mm)
	18' 0" (5486.4 mm)	3' 6" (1066.8 mm)
	20' 0" (6096 mm)	4' 6" (1371.6 mm)
30° 0"	12' 0" (3657.4 mm)	0' 6" (152.4 mm)
	14' 0" (4267.2 mm)	0' 6" (152.4 mm)
	16' 0" (4876.6 mm)	0' 10" (254 mm)
	18' 0" (5486.4 mm)	4' 0" (1219.2 mm)
	20' 0" (6096 mm)	4' 10" (1473.2 mm)
33° 7"	12' 0" (3657.4 mm)	0' 8" (203.2 mm)
	14' 0" (4267.2 mm)	0' 8" (203.2 mm)
	16' 0" (4876.6 mm)	1' 2" (355.6 mm)
	18' 0" (5486.4 mm)	4' 4" (1320.6 mm)
	20' 0" (6096 mm)	5' 0" (1524 mm)

IF THE MINIMUM DISTANCE "C" CANNOT BE MET, ADDITIONAL SPRINKLERS WILL BE REQUIRED ON THE HORIZONTAL CEILING

Figure 8 – Obstruction to discharge by intersecting horizontal ceiling.

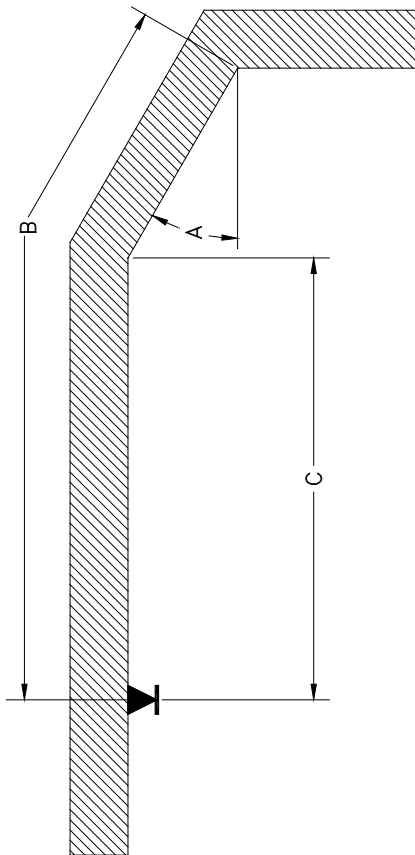

**PENDENT SPRINKLER ELEVATION**

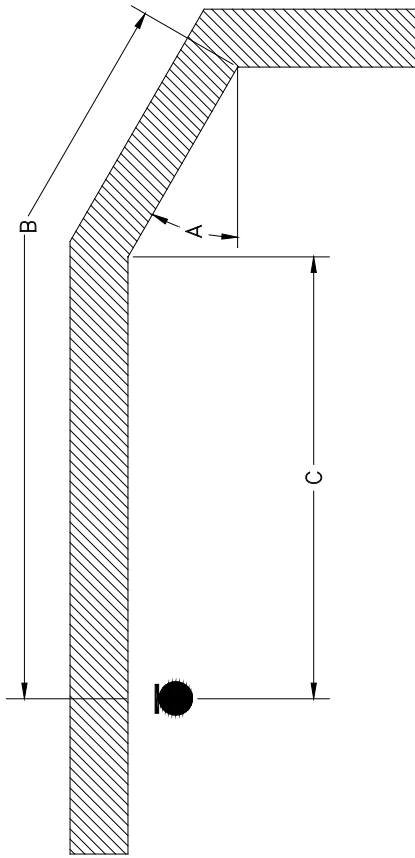

**SIDEWALL SPRINKLER ELEVATION**

A - ACCEPTABLE CEILING ANGLE 10° - 60°

B - ONE-HALF THE MAXIMUM LISTED SPRINKLER SPACING (SEE TECHNICAL BULLETINS REFERENCED IN TABLE A) FOR THE COVERAGE AREA, MEASURED ALONG THE SLOPE.

C - MINIMUM DISTANCE TO INTERSECTING HORIZONTAL CEILING

<u>CEILING ANGLE (A)</u>	<u>DISTANCE (C)</u>
10°	1' 0" (304.8 mm)
15°	1' 0" (304.8 mm)
18.4°	1' 0" (304.8 mm)
20°	1' 0" (304.8 mm)
25°	1' 0" (304.8 mm)
30°	1' 0" (304.8 mm)
35°	1' 0" (304.8 mm)
40°	1' 0" (304.8 mm)
45°	2' 0" (609.6 mm)
50°	2' 0" (609.6 mm)
60°	2' 0" (609.6 mm)

Figure 9 – Obstruction to discharge by intersecting sloped ceiling.



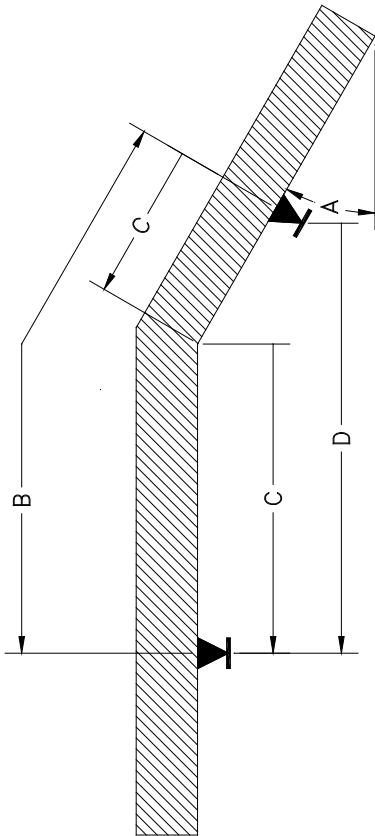
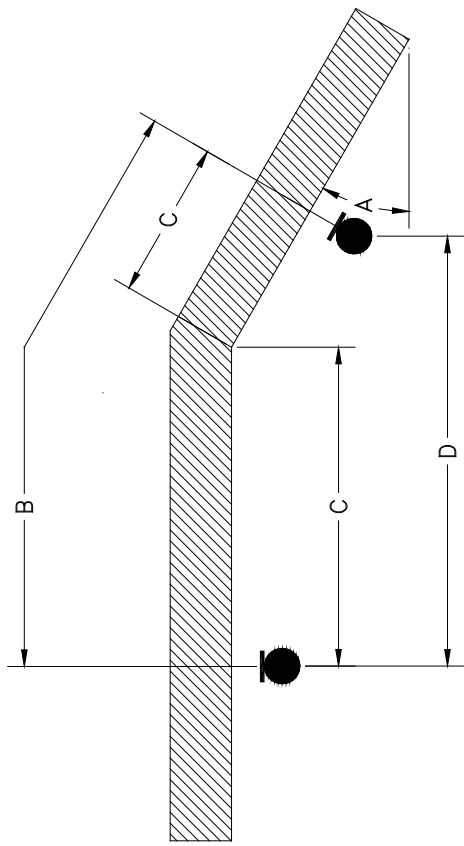

- A - ACCEPTABLE CEILING ANGLE 10° - 33.7°
- B - ONE-HALF THE MAXIMUM LISTED SPRINKLER SPACING (SEE TECHNICAL BULLETINS REFERENCED IN TABLE A) FOR THE COVERAGE AREA, MEASURED ALONG THE SLOPE.
- C - MINIMUM DISTANCE TO INTERSECTING CEILING, AS PERMITTED BY FIGURE 9.
- D - MINIMUM 8' 0" (2438.4 mm)

Figure 10 – Minimum distance between sprinklers on intersecting ceilings.

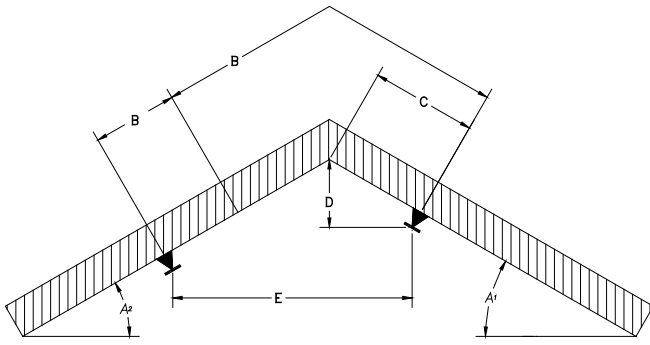

**PENDENT SPRINKLER**

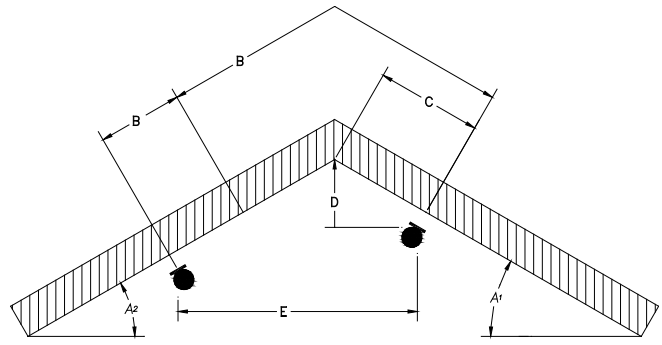

**SIDEWALL SPRINKLER**

*A<sub>1</sub>, A<sub>2</sub> - ACCEPTABLE CEILING ANGLES 10° - 33.7°. USE THE GREATER ANGLE "A<sub>1</sub>" OR "A<sub>2</sub>"  
 B - ONE-HALF THE MAXIMUM SPRINKLER SPACING (SEE TECHNICAL BULLETINS REFERENCED IN TABLE A) FOR THE COVERAGE AREA, MEASURED ALONG THE SLOPE.  
 C - MINIMUM DISTANCE TO INTERSECTING OPPOSED SLOPE AS SPECIFIED BELOW:*

<u>CEILING ANGLE (A)</u>	<u>SPRINKLER SPACING (FT.)</u>	<u>MINIMUM SLOPED DISTANCE (C)</u>
10' 0"	12' 0" (3657.4 mm)	1' 0" (304.8 mm)
	14' 0" (4267.2 mm)	1' 0" (304.8 mm)
	16' 0" (4876.6 mm)	1' 0" (304.8 mm)
	18' 0" (5486.4 mm)	1' 0" (304.8 mm)
	20' 0" (6096 mm)	1' 0" (304.8 mm)
15' 0"	12' 0" (3657.4 mm)	1' 0" (304.8 mm)
	14' 0" (4267.2 mm)	1' 0" (304.8 mm)
	16' 0" (4876.6 mm)	1' 0" (304.8 mm)
	18' 0" (5486.4 mm)	1' 0" (304.8 mm)
	20' 0" (6096 mm)	2' 0" (609.6 mm)
18' 4"	12' 0" (3657.4 mm)	1' 0" (304.8 mm)
	14' 0" (4267.2 mm)	1' 0" (304.8 mm)
	16' 0" (4876.6 mm)	1' 0" (304.8 mm)
	18' 0" (5486.4 mm)	1' 0" (304.8 mm)
	20' 0" (6096 mm)	2' 0" (609.6 mm)
20' 0"	12' 0" (3657.4 mm)	1' 0" (304.8 mm)
	14' 0" (4267.2 mm)	1' 0" (304.8 mm)
	16' 0" (4876.6 mm)	1' 0" (304.8 mm)
	18' 0" (5486.4 mm)	1' 0" (304.8 mm)
	20' 0" (6096 mm)	3' 0" (914.4 mm)
25' 0"	12' 0" (3657.4 mm)	1' 0" (304.8 mm)
	14' 0" (4267.2 mm)	1' 0" (304.8 mm)
	16' 0" (4876.6 mm)	1' 0" (304.8 mm)
	18' 0" (5486.4 mm)	2' 4" (711.2 mm)
	20' 0" (6096 mm)	3' 10" (152.4 mm)
30' 0"	12' 0" (3657.4 mm)	1' 4" (406.4 mm)
	14' 0" (4267.2 mm)	1' 0" (304.8 mm)
	16' 0" (4876.6 mm)	2' 0" (609.6 mm)
	18' 0" (5486.4 mm)	3' 2" (965.2 mm)
	20' 0" (6096 mm)	4' 4" (1320.8 mm)
33' 7"	12' 0" (3657.4 mm)	1' 0" (304.8 mm)
	14' 0" (4267.2 mm)	1' 6" (457.2 mm)
	16' 0" (4876.6 mm)	2' 8" (812.8 mm)
	18' 0" (5486.4 mm)	3' 8" (1117.6 mm)
	20' 0" (6096 mm)	4' 8" (1422.4 mm)

*D - 3' 0" (914.4 mm) MAXIMUM  
 E - MINIMUM 8' 0" (2438.4 mm)*

Figure 11 – Non-symmetric sprinkler locations on opposing slopes.

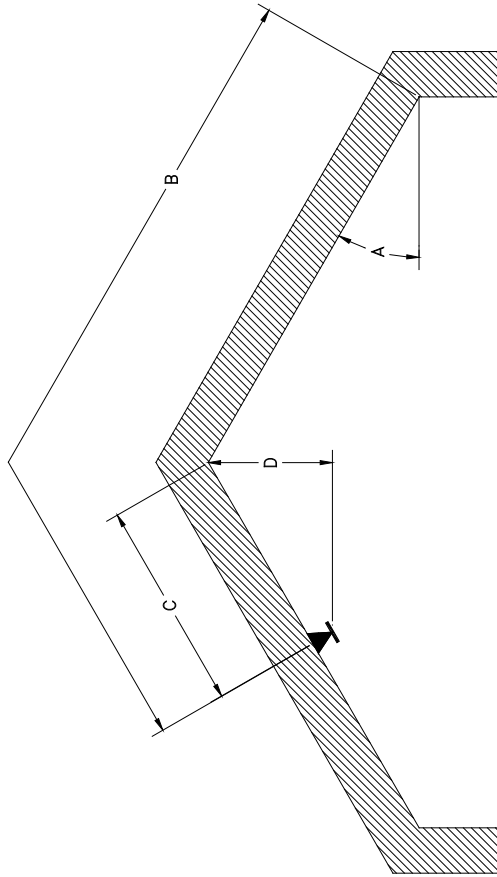

PENDENT SPRINKLER

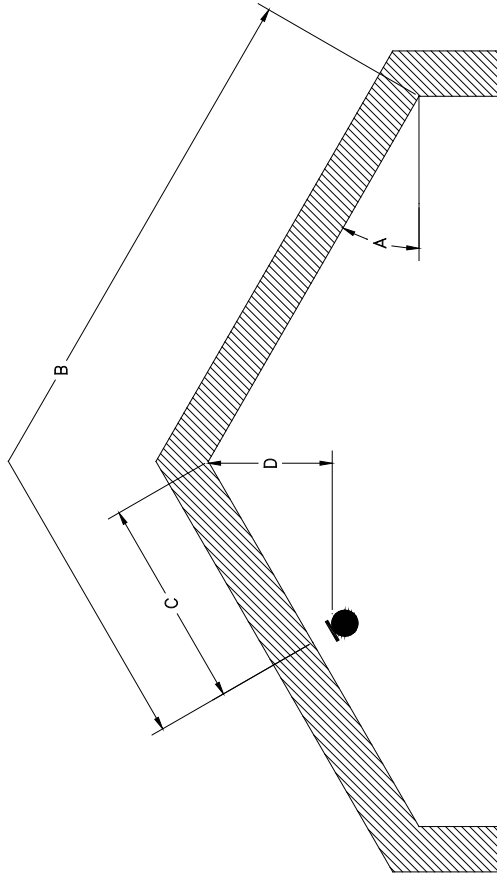

SIDEWALL SPRINKLER

- A - ACCEPTABLE CEILING ANGLES  $10^{\circ}$  -  $33.7^{\circ}$
- B - ONE-HALF THE MAXIMUM LISTED SPRINKLER SPACING (SEE TECHNICAL BULLETINS REFERENCED IN TABLE A) FOR THE COVERAGE AREA, MEASURED ALONG THE SLOPE.
- C - MINIMUM (UNOBSTRUCTED) DISTANCE TO OPPOSED SLOPE, AS PERMITTED BY FIGURE 11.
- D - 3'-0" (914.4 mm) MAXIMUM

Figure 12 – Single sprinkler coverage criteria for cathedral ceilings.

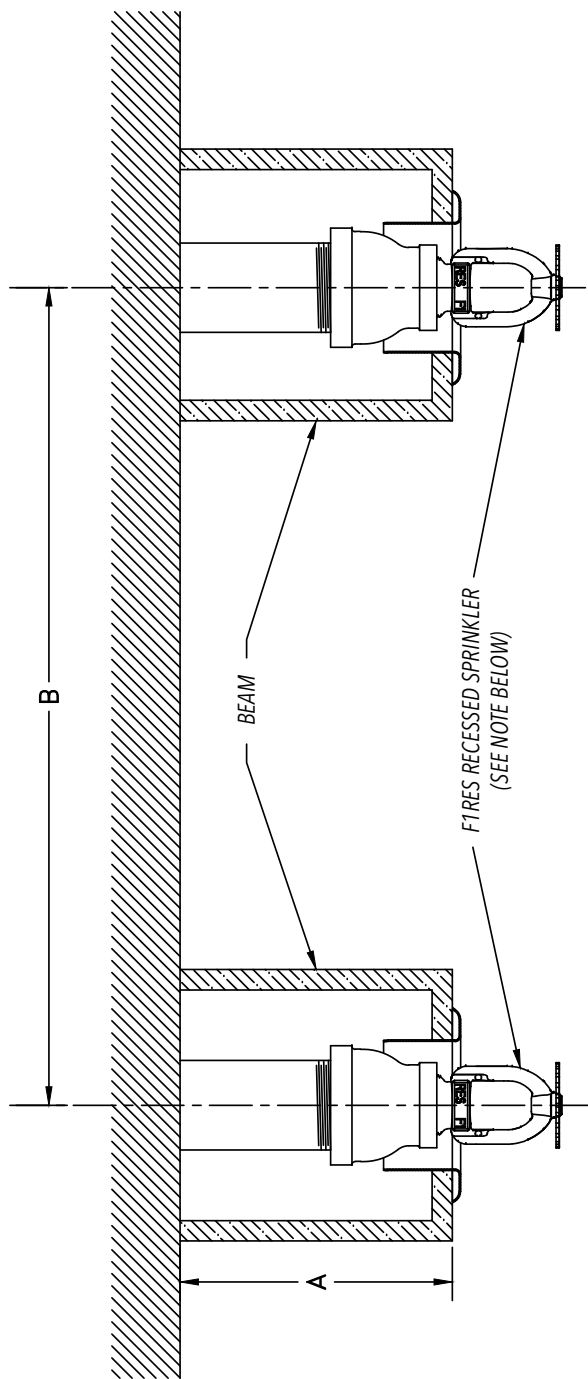

A - 14" (355.6 mm) MAXIMUM  
 B - 8' 0" (2438.4 mm) MINIMUM

NOTES: CORE DRILLING OF STRUCTURAL OR LOAD BEARING BEAMS TO ALLOW THE INSTALLATION OF SPRINKLER DROPS REQUIRES APPROVAL OF A STRUCTURAL ENGINEER.  
 RFC CONCEALED SPRINKLERS CANNOT BE INSTALLED IN STRUCTURAL BEAMS OR "FALSE" BEAMS THAT IMPEDE THE FLOW OF AIR THROUGH VENT HOLES INTO THE SPACE ABOVE.

Figure 13 – Pendent sprinkler positioning for beamed ceiling.

The equipment presented in this bulletin is to be installed in accordance with the latest published Standards of the National Fire Protection Association, Factory Mutual Research Corporation, or other similar organizations and also with the provisions of governmental codes or ordinances whenever applicable. Products manufactured and distributed by Reliable have been protecting life and property for over 90 years, and are installed and serviced by the most highly qualified and reputable sprinkler contractors located throughout the United States, Canada and foreign countries.

Manufactured by



**The Reliable Automatic Sprinkler Co., Inc.**

(800) 431-1588  
 (800) 848-6051  
 (914) 829-2042  
 www.reliablesprinkler.com

Sales Offices  
 Sales Fax  
 Corporate Offices  
 Internet Address



Revision lines indicate updated or new data.