

Reliable®

**Model DDX N2-Blast® PrePaK
Type F Preaction System
2" (50mm), 2-1/2" (65mm),
3" (80mm), 4"(100mm)**

Instructions for Installation, Operation, Care and Maintenance



Double Interlock Electric/Pneumatic Release

**8 psi - 24 psi (0.6 bar - 1.7 bar)
System Air/Nitrogen Pressure**

General Description

The Reliable Type F Model DDX PrePaK with integrated nitrogen generation is a completely self-contained, supervised preaction system that can be readily installed within a floor space of less than 7 ft² (0.65 m²) (not including door swing). Refer to Fig. 1 for cabinet dimensions. Installation of the PrePaK (not including exterior devices, i.e., detectors and alarm bells), requires just three piping connections. These connections are the water supply, the sprinkler system and the drain. Reference locations of these piping connections are shown in Fig. 1. Independent electrical supplies are required for the optional system air compressor (115 or 220 VAC), the optional Potter Model 4410 Releasing Control Panel (115/220 VAC), and the nitrogen generator (115 VAC).

Full assembly drawings for the units are available on the Reliable Automatic Sprinkler Company website (www.reliablesprinkler.com)

The Reliable Model DDX N2-Blast® PrePaK incorporates a South-Tek Systems FPS-900 pressure swing adsorption N2-Blast® nitrogen generator, complete with independent air compressor, nitrogen storage tank, control system, and AutoPurge™. The nitrogen generator is completely wired, tested, and integrated with the Model DDX PrePaK, and supplies 98% pure nitrogen to the piping network to limit electrochemical, galvanic, and micro-biologically influenced corrosion (MIC). Operation and maintenance information can be found in this bulletin as well as at the South-Tek Systems website (www.southteksystems.com).

The Reliable Type F PrePaK utilizes an optional Potter Model PFC-4410-RC Releasing/Control Panel. This fully programmable, microprocessor-based releasing panel is Underwriters Laboratories, Inc. Listed and is in compliance with NFPA 13 and NFPA 72. Because the PFC-4410-RC is totally zone and output programmable, the Reliable Type F PrePaK can be utilized in many different preaction applications without having to rewire any of the factory installed devices. Once the previously described connections are completed, the 24 VDC detectors, output devices, and relay contacts may be connected to achieve the desired system implementation.

Note: N2-Blast®, Blast-off®, and AutoPurge™ are registered trademarks of South-Tek Systems, LLC.

Reliable Automatic Sprinkler Co., Inc., 103 Fairview Park Drive, Elmsford, New York 10523

The Type F PrePaK is designed specifically for double interlock applications. Reliable double interlock preaction systems are designed for water sensitive areas that require protection from inadvertent water flow into the sprinkler system piping.

The major benefits of a double interlock preaction System, when compared with a wet pipe system, are as follows:

- A. A fire alarm sounds prior to the flow of water from a sprinkler, which may enable extinguishment of the fire by handheld means before the operation of any sprinkler occurs.
- B. An annunciator signals whenever the integrity of piping or sprinklers is accidentally or intentionally disturbed; however, no water flow occurs at that time.
- C. Detection and notification of a fire condition are provided by fire detectors, without the delay associated with water delivery time in the event of a fire. Note that with a wet pipe system, the fire alarm is delayed until after water has begun flowing from and operated sprinkler.

To flow water into the system piping of a Type F double interlock preaction system, two events must take place:

- 1) A fire detection device must detect heat and/or smoke thereby causing the releasing/control panel to energize the normally-closed solenoid valve.
- 2) The sprinkler system piping must discharge enough supervisory air for the Model LP Dry Pilot Actuator to operate. This is generally the result of a sprinkler operating due to fire.

In the event that the system piping is ruptured, or a sprinkler head is accidentally opened, the Model LP Dry Pilot Actuator will open and a low system air pressure alarm will sound. The Model DDX Deluge Valve, however, will not be released to flow water since the solenoid valve still remains closed. Conversely, in the event of a false detection signal, the releasing/control panel will activate an alarm, but the Model DDX Deluge Valve will not flow water due to the fact that the Model LP Dry Pilot Actuator remains closed.

When using the Reliable Type F PrePaK in double interlock applications the sprinkler system is pressurized (supervised) with air provided by the optional factory-installed air compressor (or on-site Nitrogen supply) and is monitored by a system pressure switch. If Nitrogen is used as the supervisory gas, an optional Nitrogen Kit is available. This kit contains a regulator and an additional pressure switch that is used to monitor any low pressure conditions that may arise due to having a limited Nitrogen supply. The optional factory-installed air compressor can be utilized for make-up air until the Nitrogen supply can be replenished.

Note: Compressed air is not to be considered as dry air and may create ice plugs in the sprinkler system piping.

A Model B Hydraulic Manual Emergency Releasing station is standard equipment in the Type F PrePaK. It consists of an aluminum nameplate mechanically attached to a ball valve. The valve handle in its OFF position is guarded against accidental turning to the ON position (and system discharge) by a nylon cable tie provided with the PrePaK assembly. The cable tie is designed to allow, in case of an emergency, forceful turning of the valve handle to the ON position.

Approvals

- The Model DDX N2-Blast PrePaK Type F preaction system is FM Approved as a factory-assembled Preaction System to Approval Standard 1011/1012/1013, Deluge and Preaction Sprinkler Systems.
- The Model DDX deluge valve and Type F preaction trim are FM Approved and cULus Listed.
- The South-Tek N2-Blast® Model FPS-900-RS nitrogen generator is FM Approved to Approval Standard 1035, Nitrogen Generators for Corrosion Mitigation.
- OSHPD Special Seismic Certification Preapproval (OSP) for SDS=2.50 and z/H=1, when installed with optional seismic kit.

Technical Data

1. The Reliable Model DDX Type F PrePaK is rated for a minimum water supply pressure of 20 psi (1.4 bar). When fitted with the optional 300 psi (20.7 bar) solenoid, the 2", 2-1/2", 3", and 8" sizes are rated for a maximum pressure of 250 psi (17.2 bar), and the 4" and 6" sizes are rated for a maximum pressure of 300 psi (20.7 bar). Water temperature must be maintained between 40°F and 140°F (4°C and 60°C).
2. Friction loss, expressed in equivalent length of Schedule 40 pipe and based on Hazen-Williams Formula is:

System Size:	Equivalent Length
2" (50mm)	19.4 ft (1.3 m)
2½" (65mm)	24.5 ft (1.8 m)
3" (80mm)	28.9 ft (3.8 m)
4" (100 mm)	32.8 ft (17.7 m)

These values account for the Model DDX Deluge Valve, supply manifold tee, butterfly control valve, and small pipe/manifold located directly above Model DDX Deluge Valve.

3. Shipping Weight:

System Size	Weight
2" (50mm)	950 lbs (431 kg)
2-1/2" (65mm)	
3" (80mm)	
4" (100 mm)	1075 lbs (488 kg)

4. Please reference Figure 1 for dimensions.

The following is a list of Technical Data Bulletins which describe the valves and devices which are used in the system:

Device	Reliable Bulletin # (unless otherwise noted)
Model DDX Deluge Valve	Reliable Bulletin 519
Type F Double Interlock Preaction Trim	Reliable Bulletin 751
Low Air Pressure Switch	Potter, 5401564
Alarm Pressure switch	Potter, 5400928
Releasing Control Panel	Potter Manual #5403550

ASSEMBLY DIMENSIONS

SYSTEM SIZE	A	B	C	D	E	F	G	H	J	K (RIGHT)	K (LEFT)	L	
												WITHOUT SYSTEM SIDE VALVE	WITH SYSTEM SIDE VALVE
2" (50MM)	30.0 [76.2]	33.1 [84.0]	74.0 [187.9]	60.0 [152.4]	12.8 [32.4]	19.7 [50.0]	19.7 [50.0]	11.6 [29.4]	11.6 [29.4]	8.0 [20.3]	2.0 [5.1]	34.0 [86.3]	30.0 [76.2]
2-1/2" (65MM)	30.0 [76.2]	33.1 [84.0]	74.0 [187.9]	60.0 [152.4]	12.8 [32.4]	19.7 [50.0]	19.7 [50.0]	11.6 [29.4]	11.6 [29.4]	8.0 [20.3]	2.0 [5.1]	34.0 [86.3]	30.0 [76.2]
3" (80MM)	30.0 [76.2]	33.1 [84.0]	74.0 [187.9]	60.0 [152.4]	12.8 [32.4]	19.7 [50.0]	19.7 [50.0]	11.6 [29.4]	11.6 [29.4]	8.0 [20.3]	2.0 [5.1]	34.0 [86.3]	30.0 [76.2]
4" (100MM)	30.0 [76.2]	33.1 [84.0]	74.0 [187.9]	60.0 [152.4]	12.8 [32.4]	19.7 [50.0]	19.7 [50.0]	11.6 [29.4]	11.6 [29.4]	8.0 [20.3]	2.0 [5.1]	34.0 [86.3]	29.5 [74.9]

SOME COMPONENTS OMITTED FOR CLARITY

DIMENSIONS: INCHES
[CM]

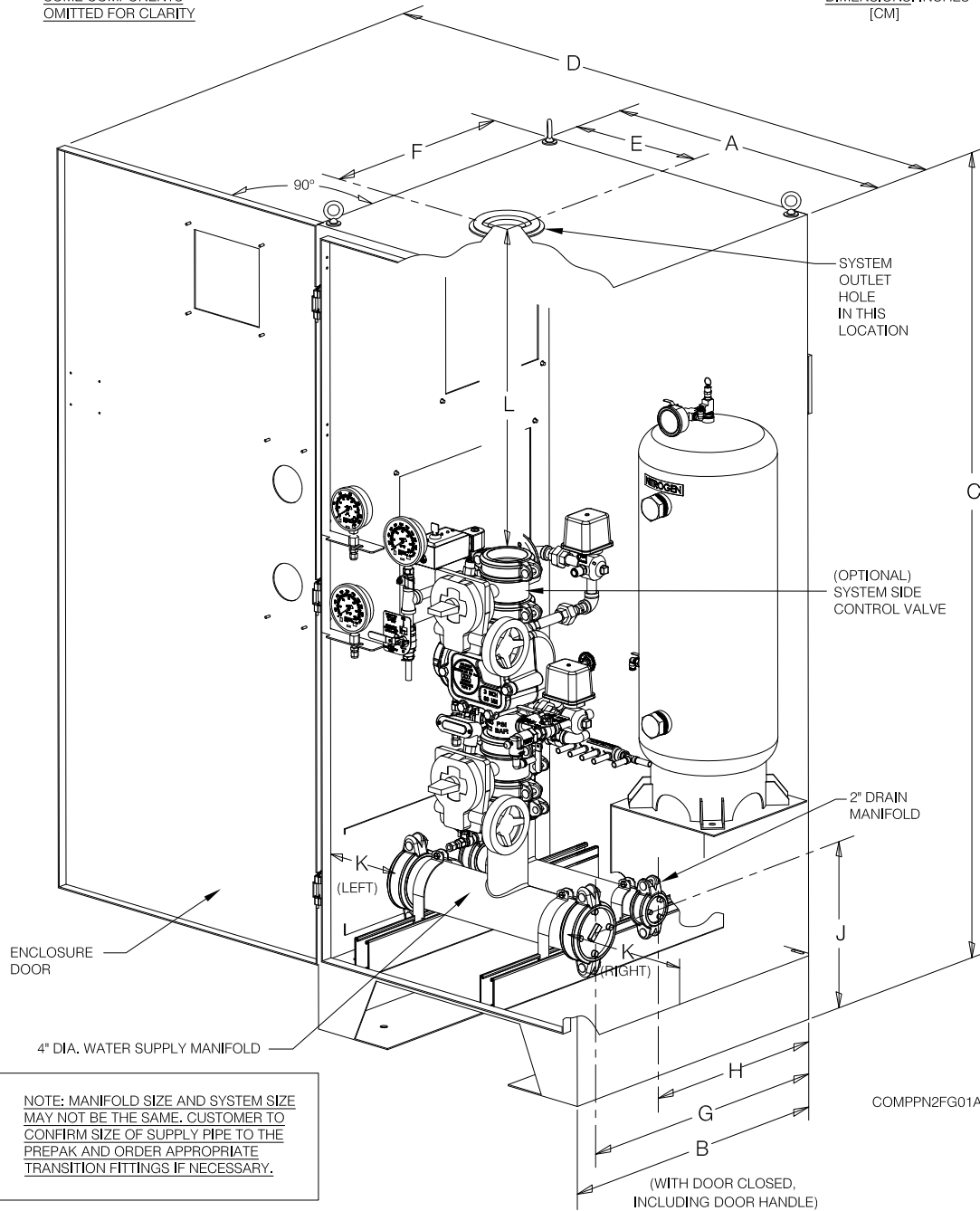

Fig. 1

The following table provides a quick reference to the various programs (found in this bulletin and the Potter Manual #5403550) that may be utilized with a Type F PrePaK:

Desired Application	Program
Single Interlock, Single Zone	Potter Program #6 (Factory Setting)
Single Interlock, Cross-Zoned	Potter Program #7

Note: The Model DDX Type F PrePaK Double Interlock Preaction system utilizes a solenoid controlled by single interlock programming in conjunction with a pneumatic (mechanical) actuator.

Installation Requirements

The automatic sprinklers, releasing devices, fire detection devices, manual pull stations, and signaling devices which are utilized with the Reliable Model DDX Type F PrePaK must be UL and/or ULC Listed or FM Approved, as applicable.

The steel enclosure and all the interconnecting piping must be located indoors in a readily visible and accessible location and in an area that can be maintained at a minimum temperature of 40°F (4°C). Note: Heat tracing is not permitted. The solenoid valve is operated and supervised by the Potter Model PFC-4410-RC Releasing Control Panel. Details on the electrical connections of this system to the Potter Panel can be found in the Potter Manual #5403550, Installation, Operation and Instruction of PFC-4410-RC Releasing Control Panel (this manual is included with other pertinent manuals and shipped inside the enclosure). This panel is fully zone and output programmable and may be adapted to several applications. Hydrostatic Testing of DDX Valves and DDX Systems.

Hydrostatic Testing of DDX Valves and DDX Systems

As required by NFPA 13, fire sprinkler systems with working pressures up to and including 150 psi are to be hydrostatically tested at a water pressure of 200 psi. Fire sprinkler systems with working pressures above 150 psi are required to be hydrostatically tested at 50 psi above the system working pressure. In addition to the hydrostatic tests described above, dry pipe and double interlock preaction systems require an additional low pressure air test.

In some cases, hydrostatic testing (in accordance with the NFPA 13 requirements noted above) will result in pressures that exceed the working pressure of the valve and trim kit for the two-hour test period. The valve and applicable trim kit have been tested, approved and listed under these conditions and as such, hydrostatic testing in accordance with NFPA 13 is acceptable. In addition, the clapper can remain in the closed position and the trim kit need not be isolated, as each has been designed to withstand hydrostatic testing as required by NFPA 13.

Hydrostatically testing the valve and trim to pressures higher than their rating is limited to the hydrostatic test as referenced by NFPA13. It does not address the occurrence(s) of a “water hammer” effect, which can indeed damage the valve. A “water hammer” in the water supply piping of the valve can create pressures in excess of the rated pressure and should be avoided by all necessary means. This condition may be created from improper fire pump settings, underground construction work, or an improper venting of trapped air in the water supply piping.

System Air / Nitrogen Pressure Requirements

The Model DDX Type F PrePaK includes gauges indicating the pneumatic and water pressures of Model LP Dry Pilot Actuator. Table A specifies the air or nitrogen pressure level to be applied to the Actuator. The factory installed Pressure Maintenance Device in the unit automatically provides adequate makeup air or nitrogen flow to maintain supervisory pressure with normal leakage for the system piping, while restricting the flow of makeup air or nitrogen to allow for system operation. Please note that when the optional Model B1 Accelerator is to be utilized to expedite water-delivery time, the pneumatic pressure must be not less than 15 psi (1.0 bar).

Table A

Water Pressure psi (bar)	System Air or Nitrogen Pressure psi (bar)
Maximum	Not Less Than
20 (1.4)	8 (0.6)
30 (2.1)	10 (0.7)
50 (3.4)	12 (.8)
75 (5.2)	13 (.9)
100 (6.9)	15 (1.)
125 (8.6)	16 (1.1)
150 (10.3)	17 (1.2)
175 (12.1)	18 (1.2)
200 (13.8)	19 (1.3)
225 (15.5)	21 (1.4)
250 (17.2)	22 (1.5)
275 (19.0)	23 (1.6)
300 (20.7)	24 (1.7)

Notes:

- Supervisory air or nitrogen pressure should not exceed 30 psi (2.1 bar). Excess pressure may result in damage to the actuator.
- Fastest valve operation is achieved with supervisory air or nitrogen pressure indicated; however, pressure must never be less than the minimum specified in the table above.
- Air maintenance devices that maintain a constant pressure are recommended; however, if a tank-less compressor is used, the “compressor on” setting of the pressure switch must never be lower than the minimum pressure in the table above.

When the air compressor in the Model DDX Type F PrePaK is used to initially fill the sprinkler system with air, the steel enclosure door should remain open to provide maximum intake air flow to the air compressor. The air compressor is connected to a storage tank. This tank functions as a reservoir, providing make-up air to compensate for small, intermittent leaks in the sprinkler system. It should be noted that significant leaks may overburden this storage tank, thereby causing the air compressor to continuously cycle on and off.

The factory-installed system air pressure switch may need on-site adjustment to correspond with the air pressure values found in Table A. Adjustment, if required, should be made according to Potter Bulletin 5401564 included with the switch.

System Electrical Requirements

All releasing, alarm, and detection devices in the Reliable Model DDX Type F PrePaK are supervised by a Potter Model PFC-4410-RC Releasing Control Panel. All of the terminals are translated to a water-tight terminal box mounted on the interior of the enclosure. All field wiring is connected to this terminal box. Note: The EOL (End of Line) resistors have also been relocated.

The Reliable Model DDX PrePaK is delivered with six factory-installed electrical devices. They consist of the following:

1. A system air pressure switch, which is used to monitor sprinkler piping.
2. An alarm pressure switch, which indicates an actuation of the deluge valve.
3. A normally-closed, releasing solenoid valve, which is used to actuate the deluge valve.
4. A 1/2 HP (2", 2-1/2", & 3" valve) or 1 HP (4" valve) air compressor with tank.
5. A supervised butterfly (main control) valve (Note: A system side butterfly valve is available as an option).
6. A release control disable switch (RCDS) which is used to disable the solenoid valve for test purposes.

Note: This unit is available with an optional Potter Electric Signal Co. CoilKeeper™ solenoid coil monitoring switch.

The factory electrical connections of these devices, along with information on the connection of detection devices (initiating zones 1 and 2), signaling devices, and supervisory outputs to the Potter PFC4410-RC Releasing Control Panel are included in this bulletin. The power supply, standby emergency power supply, battery charger and rectifier circuitry are all contained within the PFC4410 panel. Batteries that provide 90 hours of standby power are provided with the panel. For additional information and detailed wiring diagrams, please refer to Potter Manual #5403550 (Installation, Operation and Instruction of PFC4410-RC Releasing Control Panel).

Note: In order for the solenoid valve to maintain a warranty it must remain sealed as it came from the factory. If there are concerns about the valve's internal components, immediate replacement is recommended.

System Operation (Double Interlock)

To fully activate (discharge water from) the Reliable Model DDX Type F PrePaK system, a fire detection device must activate and pneumatic pressure must be lost from the sprinkler system piping (normally from the activation of one or more fire sprinklers).

When the system is properly set for service, the water supply pressure simultaneously acts on both the underside of the deluge valve's clapper and on the valve's push rod by means of the pressurized push rod chamber. The resultant pressure force acting on the push rod, in unison with the mechanical advantage of the deluge valve lever, is more than sufficient to hold the valve clapper in the closed position against the water supply pressure.

Energizing the releasing solenoid valve is only one of the events required towards opening the deluge valve. Air pressure in the sprinkler system must also be reduced to a level low enough to activate the Model LP Dry Pilot Actuator. Both of these events allows the deluge valve's push-rod chamber to be vented to drain through its outlet. Since the push-rod chamber pressure cannot be replenished through the inlet restriction as rapidly as it is vented, the pressure falls rapidly. When the push-rod chamber pressure drops below one-third of the water supply pressure, the force acting beneath the valve clapper becomes greater than the push-rod force acting on the lever which causes the clapper to open. Refer to Reliable Technical Bulletin 751 for further details.

Once the clapper has opened, the lever acts as a latch, preventing the clapper from returning to the closed position. Water from the supply flows through the deluge valve into the system piping and also through the alarm outlet to activate water flow alarm devices. Note that the solenoid valve will be maintained open by the Potter Model PFC-4410-RC Releasing/Control Panel latching feature until it is reset for operation.

After system shutdown and draining, the Model DDX Deluge Valve clapper is easily reset without special tools using the external reset feature. Restore detection devices by resetting or replacing any operated device. Once detection devices are restored the system can be reset (see Resetting Model DDX Type F Double Interlock Preaction System).

Resetting Model DDX Type F Double Interlock Preaction System

1. Close the valve controlling water supply to the Deluge Valve and close the air or nitrogen supply to the sprinkler system.
2. Close the pushrod chamber supply valve.
3. Open main drain valve and drain system.
4. Open all drain valves and vents at low points throughout the system, closing them when flow of water has stopped. Open the Model B Manual Emergency Station to relieve pressure in the pushrod chamber of the Deluge Valve.
5. With the alarm line valve open, push in the plunger of ball drip valve, forcing the ball from its seat, and drain the alarm line.

6. With the Model B Manual Emergency Station open, push in and rotate the Deluge Valve's external reset knob counterclockwise (when facing the valve), until you hear a distinct noise indicating that the clapper has reset. Note: The reset knob can be rotated only while pressure in the pushrod chamber is vented to atmospheric conditions (0 psig).

7. Inspect and replace any portion of the detection system and/or sprinkler system subjected to fire conditions.

8. Open the pushrod chamber supply valve and allow water to fill the pushrod chamber. Close the Model B Manual Emergency Station.

9. Purge all air from the actuation piping: Open the solenoid valve by operating a detector or an electric manual emergency station. Note that the Model LP Dry Pilot Actuator should also be open since there is no pneumatic pressure on the system.

10. While water is flowing through the solenoid valve AND the actuator, cause the actuator to close first by applying air or nitrogen pressure to the system.

11. Open the air or nitrogen supply quick fill valve to restore supervisory pressure in the sprinkler system and close the dry pilot actuator. Allow the pressure to build to the level specified in Table A, then set the pneumatic supply to automatic operation. (Note: To build supervisory air pressure in the sprinkler system, it may be necessary to temporarily close the main drain valve and the alarm line valve until air pressure has built up to the recommended level.)

12. After the Model LP Dry Pilot Actuator has been set, close the solenoid valve by resetting the release control panel. (All detectors and manual pull stations must be in a normal state before the panel can be reset.)

Note: It is important that the piping between the solenoid valve and the dry pilot actuator is filled with water and not air. This is accomplished by closing the dry pilot actuator FIRST while water is flowing through the device and closing the solenoid valve only AFTER the actuator is completely set.

13. Open the alarm line valve. Verify the main drain valve is open. Slightly open the main valve controlling water supply to the Model DDX Deluge Valve, closing the main drain valve when water flows. Observe if water leaks through the ball drip valve. If no leak occurs, the Deluge Valve clapper is sealed. Slowly open the main valve controlling water supply until fully open and verify that it is properly monitored.

14. Verify that the pushrod chamber supply valve and alarm line valve are open. The pushrod chamber supply valve must remain open when the Deluge Valve has been reset, to maintain water pressure in the pushrod chamber.

15. Verify that the Model B Manual Emergency Station is secured in the OFF position with the appropriate nylon tie.

Inspection and Testing

1. Water supply — Confirm that valves controlling water supply to the Deluge Valve are opened fully and properly monitored.

2. Alarm line — Confirm that the alarm line valve is open and remains in this position.

3. Other trim valves — Confirm that the pushrod chamber supply valve is open, as well as all pressure gauge valves. The main drain valve, condensate drain valve, and alarm test valve should be closed.

4. Ball drip valve — Push in on the plunger to be sure ball check is off its seat. If no water appears, the Deluge Valve water seat is tight. Inspect the bleed hole on the underside of the pushrod chamber for leakage.

5. Dry pilot trim — Inspect air pressure for conformance to Table A.

6. Releasing device — Check outlet of the releasing device (i.e., solenoid valve and hydraulic manual emergency station) for leakage. Also verify that tubing drain lines from releasing devices are not pinched or crushed which could prevent proper releasing of the Deluge Valve.

7. Testing alarms — Open the alarm test valve permitting water from the supply to flow to the electric sprinkler alarm switch and to the mechanical sprinkler alarm (water motor). After testing, close this valve securely. Push in on the plunger of ball drip valve until all water has drained from the alarm line.

8. Operational test — Open the Model B Manual Emergency Station. Alternatively, operate the electrical detection system and deplete pneumatic pressure from the sprinkler system.

Note: AN OPERATIONAL TEST WILL CAUSE THE DELUGE VALVE TO OPEN AND FLOW WATER INTO THE SPRINKLER SYSTEM.

9. Secure the Model B Manual Emergency Station in the OFF position with nylon tie after Deluge Valve is reset.

Testing Detection System Without Operating Deluge Valve

1. Close the valve controlling water supply to the deluge valve and open the main drain valve.

2. Verify that valve supplying hydraulic pressure to the piston/pushrod chamber is open, allowing water to enter the pushrod chamber.

3. Operate the electrical detection system and deplete pneumatic pressure from the sprinkler system.

4. Operation of the detection combined with loss of pneumatic pressure must result in a sudden drop of water pressure in the pushrod chamber, as indicated by the pressure gauge on the hydraulic release trim.

5. Reset the valve per the reset instructions.

Maintenance

The owner is responsible for maintaining the fire protection system in proper operating condition. Any system maintenance or testing that involves placing a control valve or detection/control system out of service may eliminate the fire protection that is provided by the fire protection system.

The Reliable Model DDX valve and associated equipment shall periodically be given a thorough inspection and test. NFPA 25, "Inspection, Testing, and Maintenance of Water Based Fire Protection Systems," provides minimum maintenance requirements. System components shall be tested, operated, cleaned, and inspected at least annually, and parts replaced as required. Replace any components found to be corroded, damaged, worn, or non-operable. Increase the frequency of inspections when the valve is exposed to corrosive conditions or chemicals that could impact materials or operation of the assembly.

If face plate is removed during maintenance, torque face plate bolts to the following values during re-installation:
35 ft-lbs. (47 N-m) for 2" through 4" valves
70 ft-lbs. (95 N-m) for 6"-8" valves

Draining Excess/Condensate Water from the System

1. Notify the owner and monitoring company that maintenance is being performed on the system.
2. Close the main water control valve.
3. Open the Main Drain Valve.
4. Open the Condensate Drain Valve until all water has drained.
5. Close Condensate Drain Valve.
6. Partially open the Main Water Control Valve.
7. Slowly close the Main Drain Valve.
8. Fully open the Main Water Control Valve.
9. Notify the owner and monitoring company that the system has been returned to service.

SOLENOID VALVE INSPECTIONS, TESTS AND MAINTENANCE

WARNING: THE OWNER IS RESPONSIBLE FOR MAINTAINING THE FIRE PROTECTION SYSTEM IN PROPER OPERATING CONDITION. ANY SYSTEM MAINTENANCE OR TESTING THAT INVOLVES PLACING A CONTROL VALVE OR DETECTION SYSTEM OUT OF SERVICE MAY ELIMINATE THE FIRE PROTECTION OF THAT SYSTEM. PRIOR TO PROCEEDING, NOTIFY ALL AUTHORITIES HAVING JURISDICTION. CONSIDERATION SHOULD BE GIVEN TO EMPLOYMENT OF A FIRE PATROL IN THE AFFECTED AREA.

WARNING: PRIOR TO OPERATING THE SOLENOID VALVE, BE SURE TO CLOSE THE SYSTEM CONTROL VALVE TO AVOID UNINTENTIONAL OPERATION OF THE DELUGE VALVE

1. Inspections: It is imperative that the system be inspected and tested in accordance with NFPA 25 on a regular basis. The frequency of the inspections may vary due to contaminated water supplies, corrosive water supplies, or corrosive atmospheres. In addition, the alarm devices, detection systems, or other connected trim may require a more frequent schedule. Refer to the system description and applicable codes for minimum requirements.
2. The valve must be inspected at least monthly for cracks, corrosion, leakage, etc., cleaned and replaced as necessary.
3. If leakage is suspected through the solenoid valve, it should be replaced.

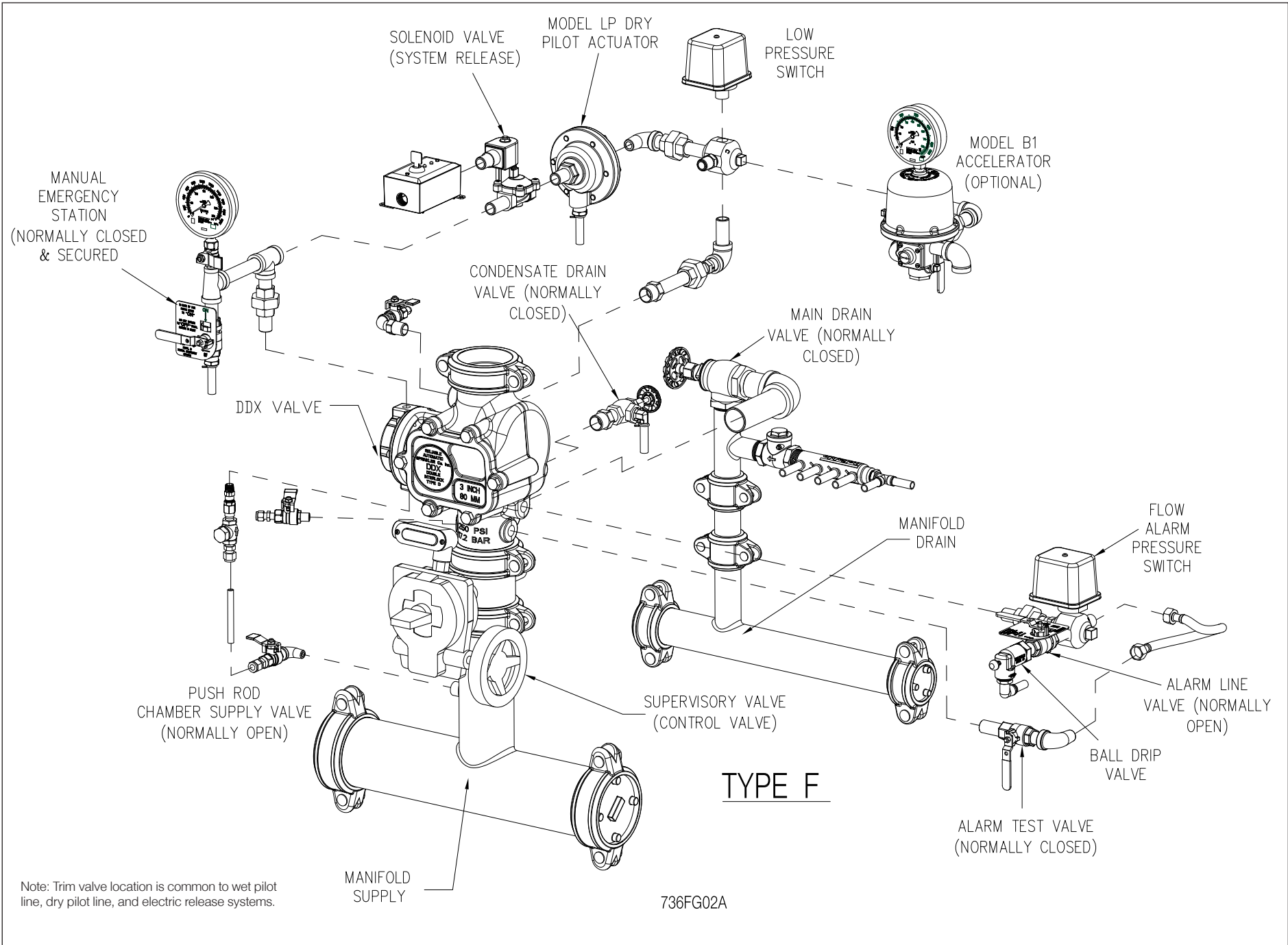
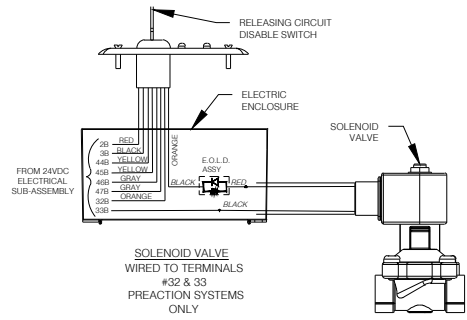
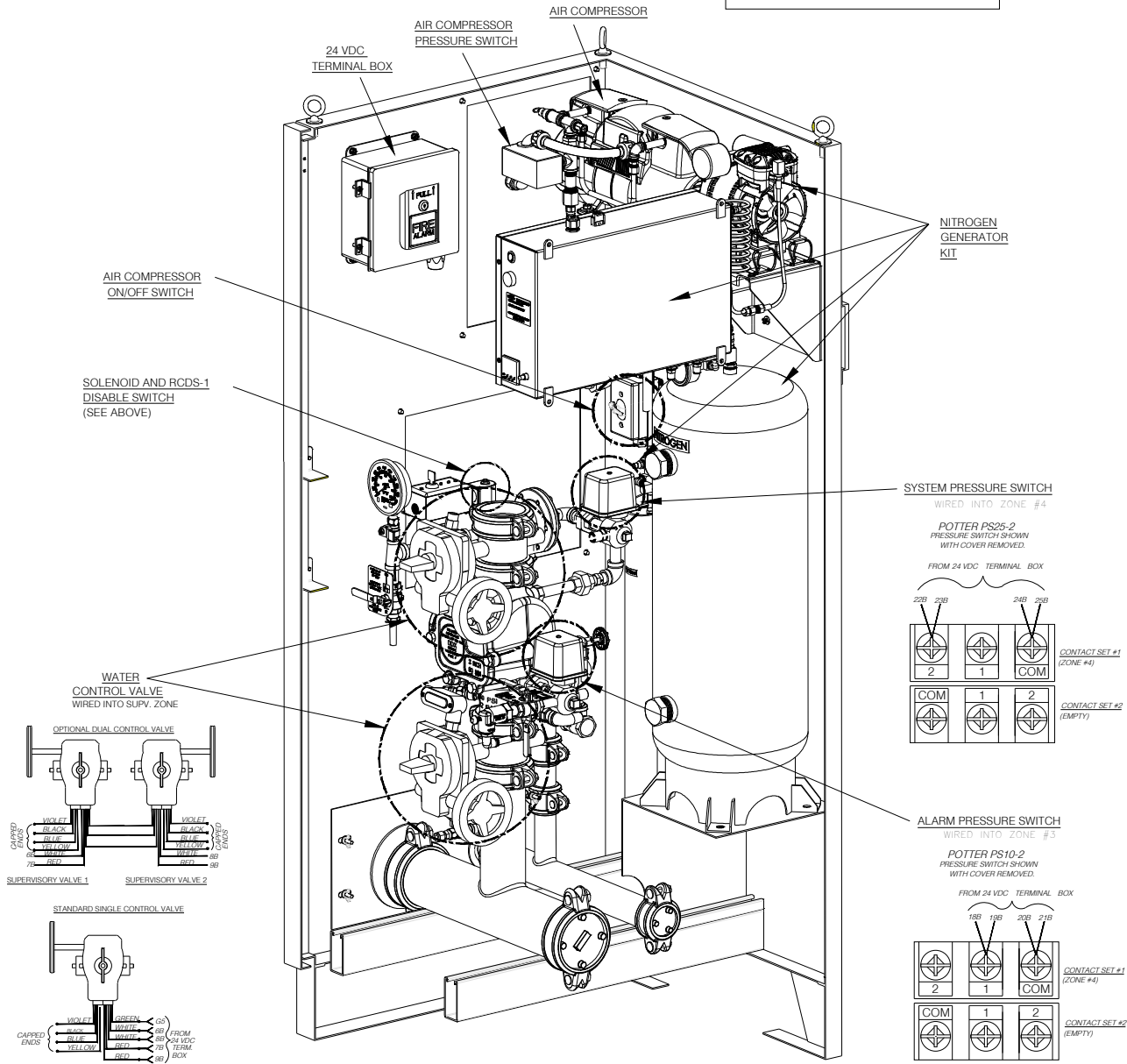

Fig. 2



NOTE: For convenience and where allowed by the approving authority, Type SO power cords are connected to the releasing panel and air compressor when such devices are present in the unit. When required, these power cords may be disconnected and replaced with wiring that is acceptable to the approving authority. Replacement of the factory installed power cords with other approved wiring does not void listing, approval, and/or warranty.



COMPNN2FG03A

FACTORY INSTALLED ELECTRICAL DEVICES
(SOME COMPONENTS OMITTED FOR CLARITY)

Fig. 3

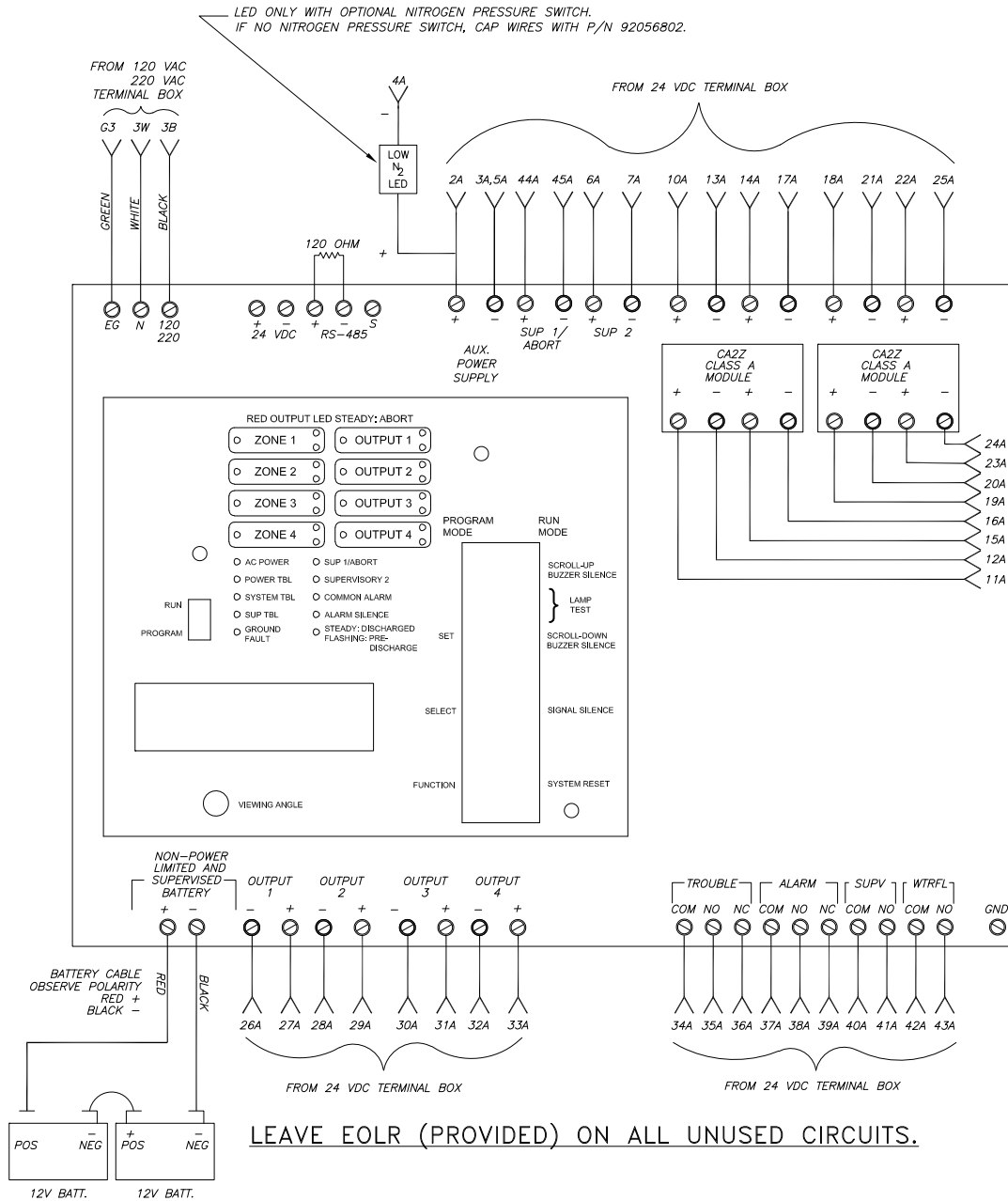

- NOTES:
1. Connect only UL listed 24VDC devices to outputs.
 2. Connect EOL diode assy. IN SERIES with solenoid on release circuit.
 3. Leave EOLR (provided) on all unused circuits.
 4. Polarity marked on outputs is for a normal, non-activated condition.
 5. Polarity reverses when output is activated.
 6. Max. current per output is 1 amp.
 7. Max. current for all outputs combined is 2.5 amps.
 8. All initiating and release circuits are supervised and power limited.

POTTER PFC-4410-RC RELEASING CONTROL PANEL

Fig. 4

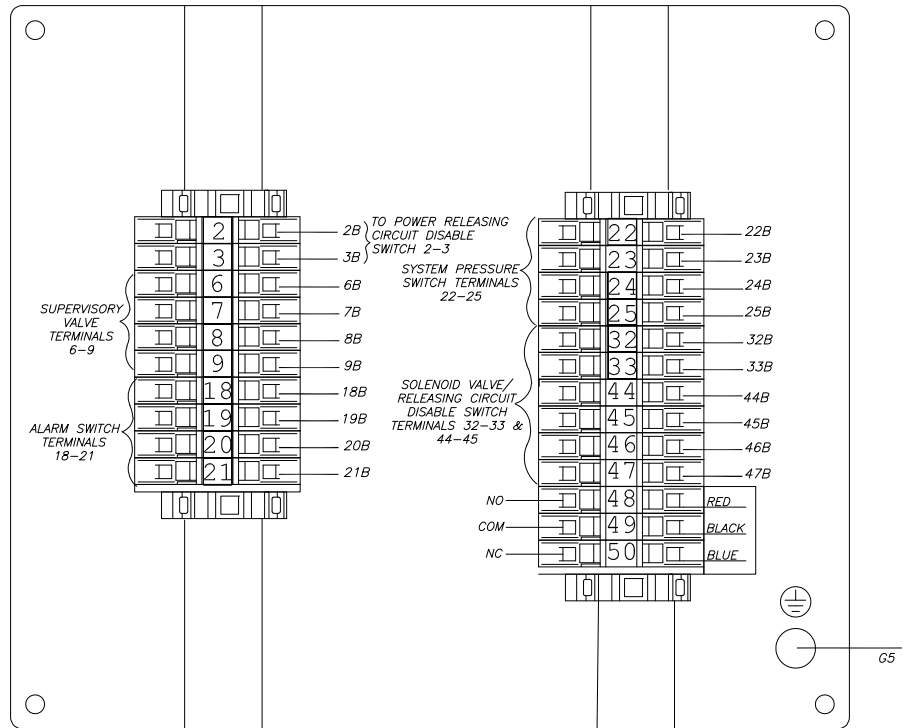

24 VDC TERMINAL BOX W/O RELEASING PANEL

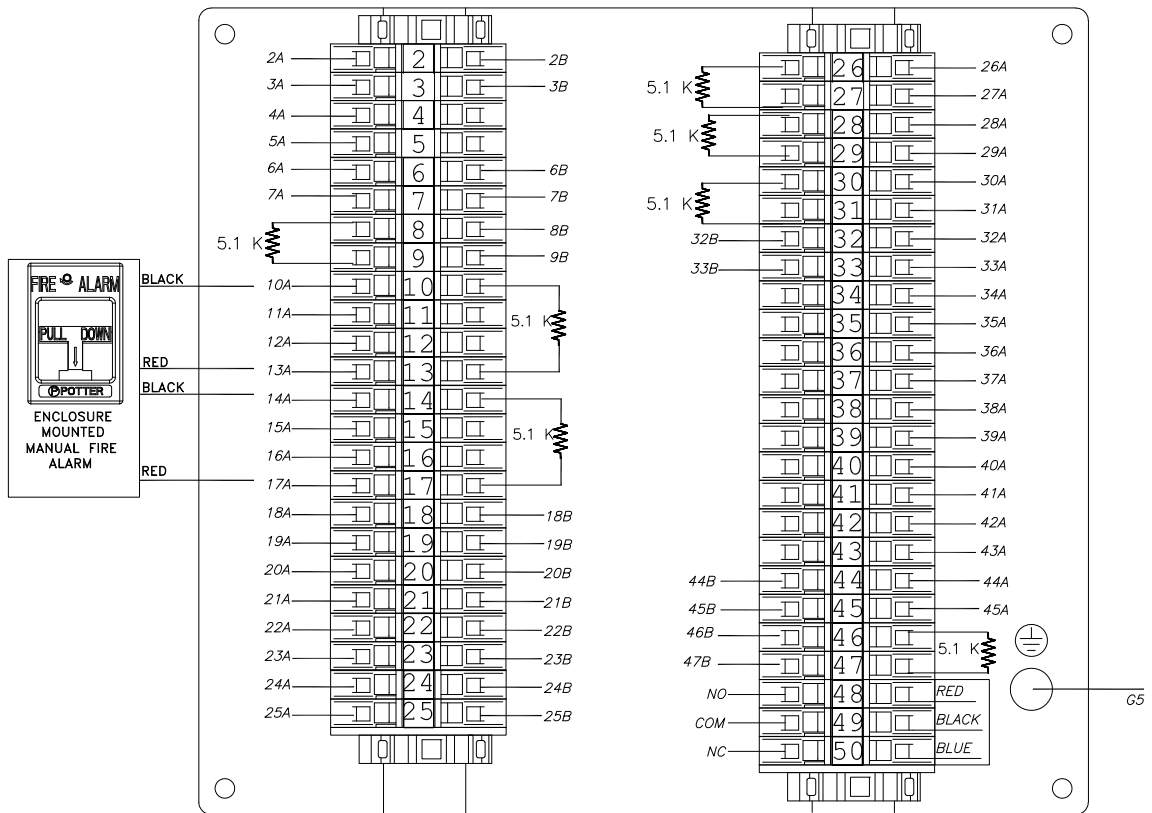

COMPPN2FG05

24 VDC TERMINAL BOX WITH RELEASING PANEL

Fig. 5

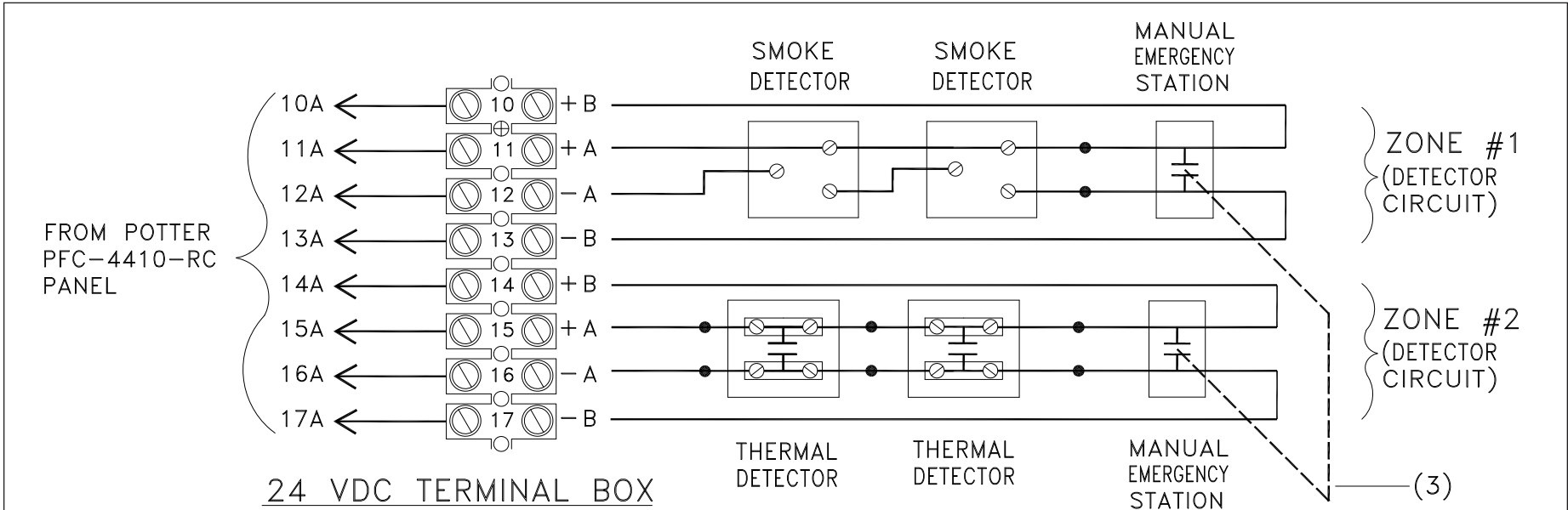

CLASS 'A' DETECTOR CIRCUIT WIRING EXAMPLE

1. THIS DRAWING IS INTENDED AS A REFERENCE ONLY. DESIGN OF THE DETECTION SYSTEM (BY OTHERS), TO MEET THE MINIMUM REQUIREMENTS OF NFPA 72 AND THE AUTHORITY HAVING JURISDICTION.
2. DETECTION DEVICES AND CIRCUITS ARE FIELD WIRED BY OTHERS.
2. ALL DEVICES MUST BE COMPATIBLE WITH POTTER PFC4410-RC IF PANEL IS PROVIDED WITH PREPAK UNIT.
3. USE MANUAL EMERGENCY STATION MODEL WHEN USING EITHER CROSS-ZONED DETECTION* OR DOUBLE INTERLOCK PREACTION SYSTEM OPTION. THIS STATION ACTIVATES BOTH DETECTION CIRCUITS SIMULTANEOUSLY.

*NOT PERMITTED IN NEW YORK CITY.
 *NOT FM APPROVED.

COMPPFG06

Fig. 6

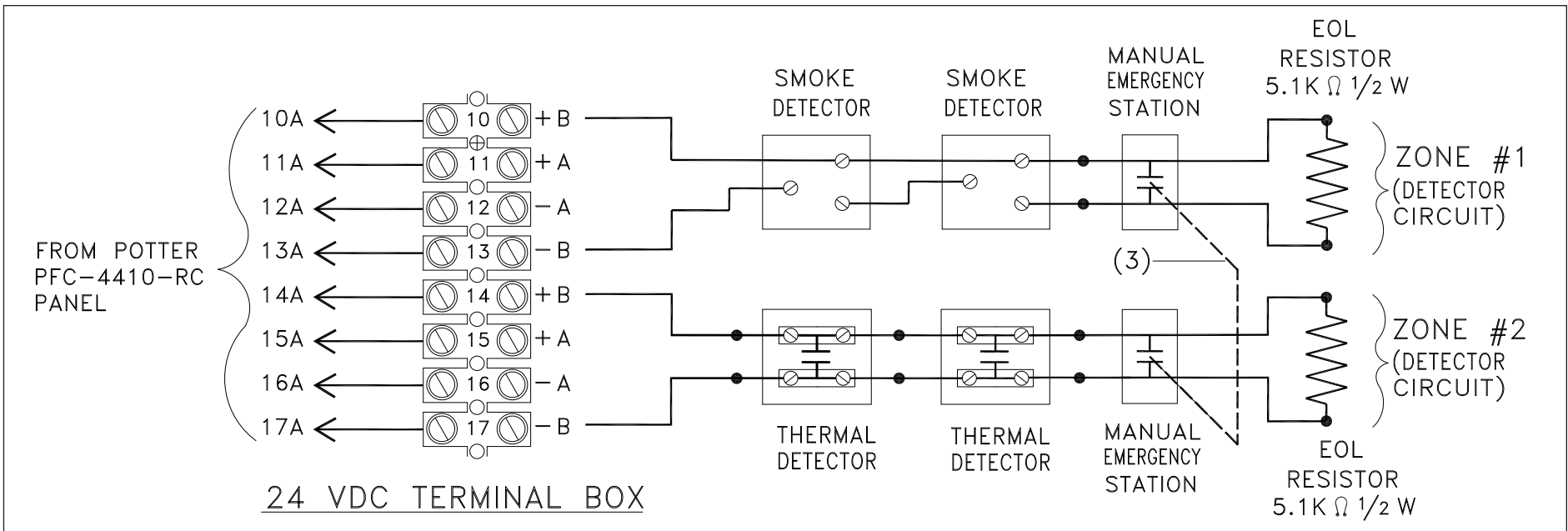

CLASS 'B' DETECTOR CIRCUIT WIRING EXAMPLE

1. THIS DRAWING IS INTENDED AS A REFERENCE ONLY. DESIGN OF THE DETECTION SYSTEM (BY OTHERS), TO MEET THE MINIMUM REQUIREMENTS OF NFPA 72 AND THE AUTHORITY HAVING JURISDICTION.
2. DETECTION DEVICES AND CIRCUITS ARE FIELD WIRED BY OTHERS.
2. ALL DEVICES MUST BE COMPATIBLE WITH POTTER PFC4410-RC IF PANEL IS PROVIDED WITH PREPAK UNIT.
3. USE MANUAL EMERGENCY STATION MODEL WHEN USING EITHER CROSS-ZONED DETECTION* OR DOUBLE INTERLOCK PREACTION SYSTEM OPTION. THIS STATION ACTIVATES BOTH DETECTION CIRCUITS SIMULTANEOUSLY.

*NOT PERMITTED IN NEW YORK CITY.
 *NOT FM APPROVED.

COMPPFG07

Fig. 7

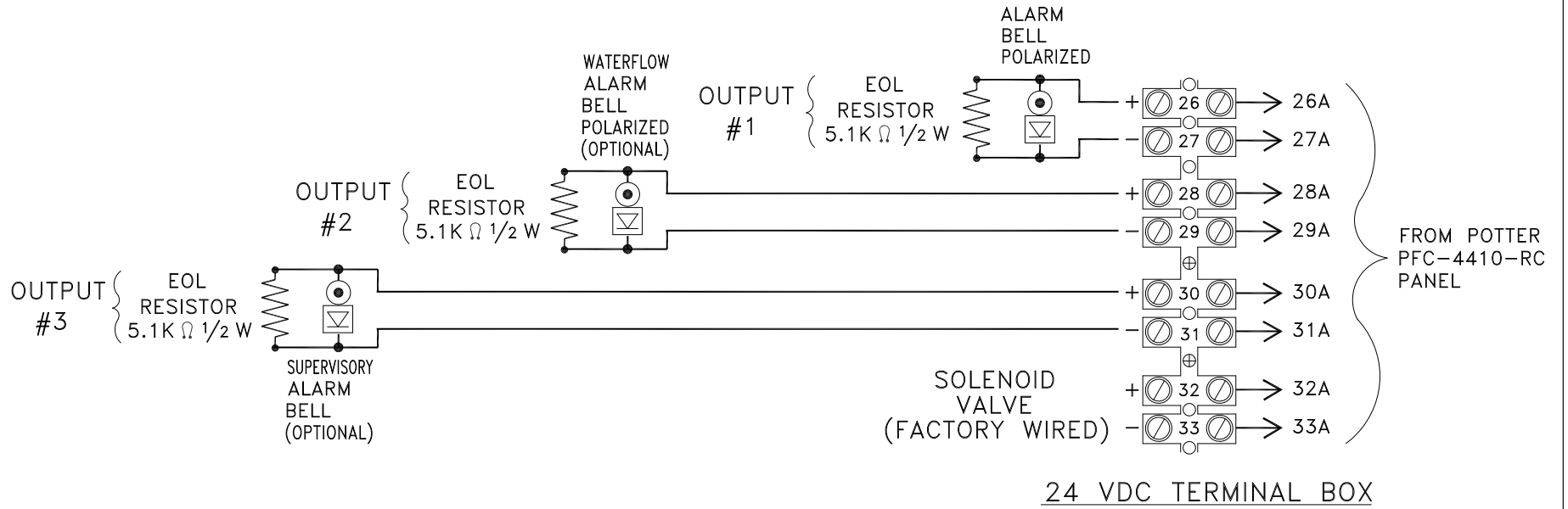

OUTPUT DEVICE CIRCUIT WIRING

COMPPFG08

Fig. 8 — Wiring Diagram

POTTER PFC4410-RC WIRING SCHEMATIC

Note: Inputs and outputs are mapped to the 24VDC terminal block within the PrePak cabinet; however, not all circuits may be necessary depending on the type of system and program utilized.

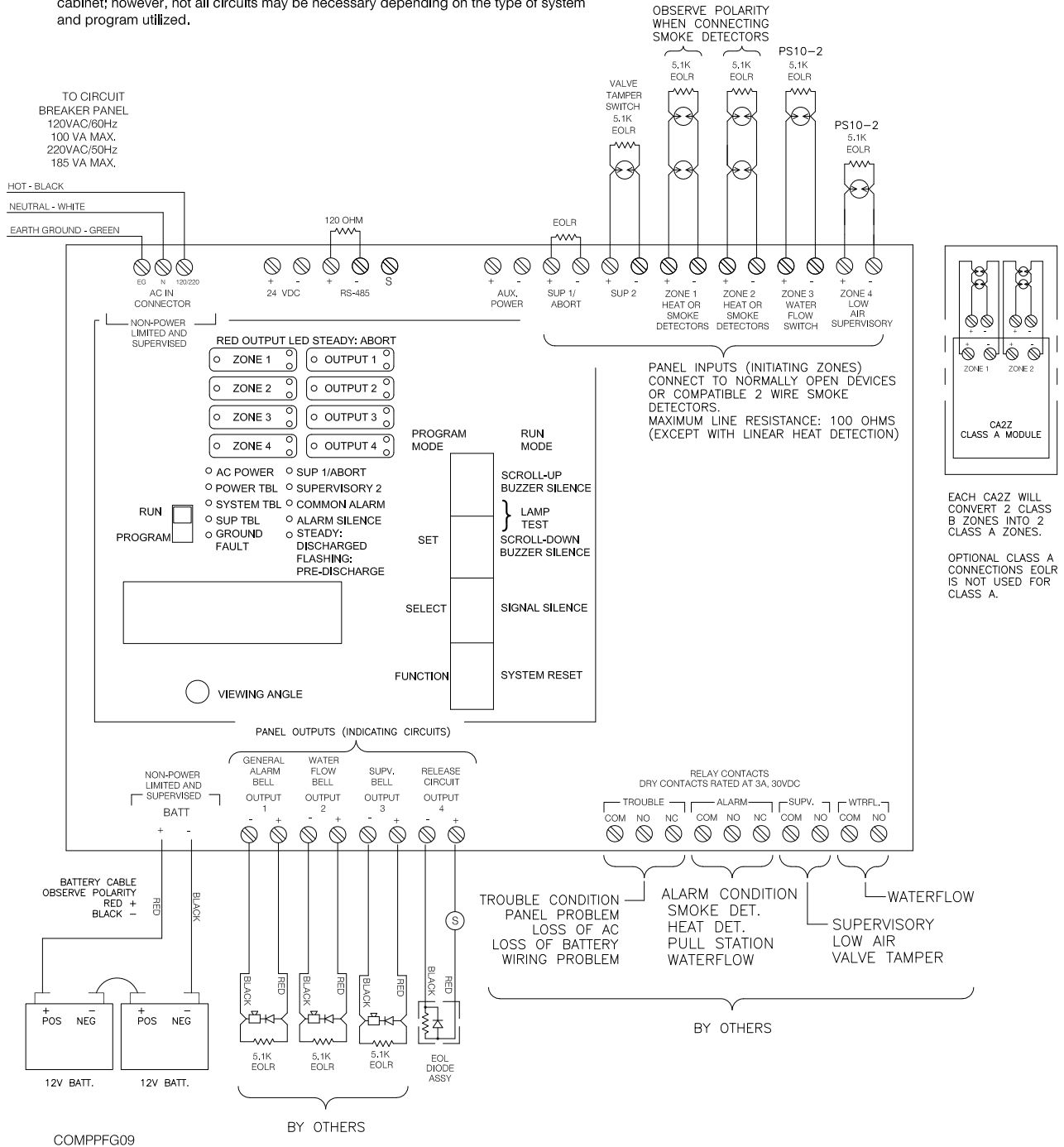

NOTES:

1. Connect only UL listed 24VDC devices to outputs.
2. Connect EOL diode assembly IN SERIES with solenoid on release circuit.
3. Leave EOL resistor on all unused circuits.
4. Polarity marked on outputs is for a normal, non-activated condition.
5. Polarity reverses when output is activated.
6. Max. current per output is 1 amp.
7. Max. current for all outputs combined is 2.5 amps.
8. All initiating and release circuits are supervised and power limited.

Fig. 9 — Wiring Diagram

Single Interlock, Single Detection Zone

Potter Program #6

1. Apply power to panel.
2. Slide the program switch down.
3. Press the FUNCTION button until the display reads "PASSWORD=000."
4. To enter a password, press the SELECT button until the proper number is displayed above the "^" symbol; then press the SET button to move to the next digit. After entering the third number the display will change. (All panels are shipped with a "000" password.)
5. Press the FUNCTION button until the display reads "PROGRAM ##." (the second "#" character refers to the current program number between "0" and "24").
6. Press the SELECT button until the display reads "PROGRAM #6."
7. Press the SET button
8. The panel is completely programmed except for the custom banner and zone messages. Slide the program switch back up.

POTTER PROGRAM #6

OUTPUTS	ZONES				
	Supervisory 2 ⁽¹⁾	#1 Conventional ⁽²⁾	#2 Conventional ⁽²⁾	#3 Waterflow	#4 Low Air Supervisory
#1 ALARM		X			
#2 WATERFLOW				X	
#3 SUPERVISORY	X				X
#4 RELEASE		X			

INPUTS: 1 conventional zone, 1 manual release zone, 1 waterflow zone, 1 low air zone, 1 supervisory zone.

OUTPUTS: 1 general alarm bell, 1 waterflow bell, 1 supervisory bell, 1 solenoid release circuit.

OPERATION: Activation of either conventional zone (or operation of the manual pull station within the PrePak cabinet) will operate the solenoid release circuit and the general alarm bell. Activation of the waterflow zone will operate the waterflow bell. Activation of either the low air zone or the supervisory zone will operate the supervisory bell. When either Zone #1 or #2 is in alarm, Output #1 (general alarm) and Output #4 (solenoid release) will operate. When Zone #3 is in alarm, Output #2 (waterflow bell) will operate. When either Zone #4 or the supervisory zone is activated, Output #3 (supervisory bell) will operate.

Note:

⁽¹⁾ The Butterfly valve in the PrePaK assembly is connected to Supervisory 2 input of the Potter PFC-4410RC Releasing/Control panel

⁽²⁾ The emergency manual release within the PrePak cabinet is wired into the conventional detection zones 1 and 2, and is designed to release the solenoid for setup and testing purposes.

For additional information, please refer to the "Installation, Operation, and Instruction Manual" for the Potter PFC4410-RC Releasing Control Panel (provided with the unit).

Single Interlock, Cross Zoned Detection

Potter Program #7

1. Apply power to panel.
2. Slide the program switch down.
3. Press the FUNCTION button until the display reads "PASSWORD = 000."
4. To enter a password, press the SELECT button until the proper number is displayed above the "^" symbol; then press the SET button to move to the next digit. After entering the third number the display will change. (All panels are shipped with a "000" password).
5. Press the FUNCTION button until the display reads "PROGRAM ##." (the second "#" character refers to the current program number between "0" and "24").
6. Press the SELECT button until the display reads "PROGRAM #7."
7. Press the SET button.
8. The panel is completely programmed except for the custom banner and zone messages. Slide the program switch back up.

POTTER PROGRAM #7

OUTPUTS	ZONES				
	Supervisory 2 ⁽¹⁾	#1 Conventional ⁽²⁾	#2 Conventional ⁽²⁾	#3 Waterflow	#4 Low Air Supervisory
#1 ALARM		X	X		
#2 WATERFLOW				X	
#3 SUPERVISORY	X				X
#4 RELEASE		XX	XX		

INPUTS: 2 conventional zones (cross-zoned), 1 waterflow zone, 1 low air zone, 1 supervisory zone.

OUTPUTS: 1 general alarm bell, 1 waterflow bell, 1 supervisory bell, 1 solenoid release circuit.

OPERATION: Activation of both conventional zones at the same time (or operation of the manual pull station within the PrePak cabinet) will operate the solenoid release circuit and the general alarm bell. Activation of either conventional zone will operate the general alarm bell. Activation of the waterflow zone will operate the waterflow bell. Activation of either the low air zone or the supervisory zone will operate the supervisory bell. When either Zone #1 or #2 is in alarm, Output #1 (general alarm) will operate. When Zones #1 and #2 are in alarm at the same time, Output #4 (solenoid release) and Output #1 (general alarm) will operate. When Zone #3 is in alarm, Output #2 (waterflow bell) will operate. When either Zone #4 or the supervisory zone is activated, Output #3 (supervisory bell) will operate.

Note:

⁽¹⁾ The Butterfly valve in the PrePaK assembly is connected to Supervisory 2 input of the Potter PFC-4410RC Releasing/Control panel

⁽²⁾ The emergency manual release within the PrePak cabinet is wired into the conventional detection zones 1 and 2, and is designed to release the solenoid for setup and testing purposes.

For additional information, please refer to the "Installation, Operation, and Instruction Manual" for the Potter PFC4410-RC Releasing Control Panel (provided with the unit).

FPS-900-RS Nitrogen Generator

General

This manual provides instruction for the proper use and maintenance of South-Tek Systems N2-Blast® FPS-900-RS. South-Tek Systems and Reliable are not responsible for damages when using this in manners not approved by South-Tek Systems and Reliable. The user(s) of this document should confer any questions with a qualified South-Tek Systems representative on its commissioning and correct use. Please contact South-Tek Systems with any question or concerns at:

South-Tek Systems, LLC
2940 Orville Wright Way Ste 600
Wilmington, NC, 28405
Tel: (888) 526-6284
Email: Info@southteksystems.com
http://www.southteksystems.com/

Important Information

All personnel (and their supervisors) installing, operating, and maintaining the N2-Blast® must read and fully understand this manual prior to installing, operating or performing maintenance. The N2-Blast® produces nitrogen (N₂) at a low flow rate, which quickly dissipates into the air. N₂ gas is not poisonous, but do not directly inhale since high concentrations can cause asphyxiation. Install the unit in a well-ventilated room that is not sealed off from normal living space air changes. All personnel involved with the installation, operations, and maintenance of the N2-Blast® must follow safe working practices, including OSHA and local health/safety code regulations.

Safety Guidelines

The following section outlines the basic safety considerations about installation and operation of the N2-Blast® FPS-900-RS. For other equipment used with the nitrogen generator, such as external air compressors, and dryers, refer to the manufacturer's safety guidelines.

Using the N2-Blast® FPS-900-RS correctly is important for safety and trouble-free operation. Wrong use can cause damages to the system or can lead to incorrect gas supply. The nitrogen generator produces nitrogen at a low flow rate, which quickly dissipates into the air. Nitrogen is not poisonous, but do not directly inhaled, since high concentrations, can cause asphyxiation. Install the unit in a well-ventilated room, unsealed off from normal living space air changes.

Warning: Install the unit in a within a well-ventilated room, one that is not sealed off from normal living space air changes.

Read carefully and act accordingly before operating or repairing the unit:

- The operator must use safe working practices and rules when running the nitrogen generator.
- The owner is responsible for always keeping the unit in safe working conditions.
- Always use approved parts when performing maintenance and repairs. Make sure that replacement parts meet or exceed the original parts' specification.
- Only competent individuals, trained and authorized, can install, operate, perform maintenance and repair.
- Isolate incoming and outgoing pressures to the generator, and depressurize the service or repair section before performing any mechanical work, including changing the filters.
- Vent the nitrogen generator's exhaust gas outside or to a large, well-ventilated room to avoid suffocation due to lack of oxygen.
- Wear safety glasses if the cabinet door is open while the machine is running.
- Use ear protection when the equipment is running.

NOTE: Always following local and site safety regulations in conjunction with this manual. Correct use of the nitrogen generator is important for personal safety. Incorrect safety practices can cause damage to the individual and equipment.

Follow safe working practices, OSHA, and local health and safety regulation when maintaining the N2-Blast® FPS-900-RS.

Air Supply

The N2-Blast® FPS-900-RS includes a built-in air compressor to supply gas to the nitrogen generator. It is not for performing quick fills; a separate suitable air compressor should be used to fill the system.

Electrical Requirements

The N2-Blast® FPS-900-RS requires 120VAC / 50-60hz / 1ph and draws < 8A. A 240VAC option is also available. It has a built-in 20A over-current protection device and comes with a standard 3-prong US power cord for the electrical connection (unless otherwise specified). It comes with UL 508A ICP certification, and the electrical schematics are available upon request.

Site Specifications

Unless designed otherwise, install in a nonhazardous indoor location with temperatures between 40-100°F (4°- 38°C). For ease of maintenance, troubleshooting, and minimizing pressure drop, install the equipment in the same area. Leave enough space around the generator and other equipment for routine maintenance.

Key Features

Air Compressor

An oil-less internal air compressor has an engineered dampening system reducing vibration and noise throughout the cabinet. The air compressor has a pre-filter to catch small particulates that can cause damage. The recommended replacement for the pre-filter is 1000 run hours or 1-year, whichever comes first. Dirtier environments may need more frequent changes. Consult with the supplier for a different filter maintenance schedule if installing in a dirty environment.

Air Filters

The generator has an air inlet pre-filters and two filters between the compressed air and O₂ separation beds - the particulate and coalescing. The 5-micron particulate filter catches the bulk particles, and the 0.1 micron coalescing catches the remaining smaller particles. Both filters feature an auto-drain that drains any water buildup within the filter housing. These drain lines are on the cabinet's bottom right side. Connect these drain lines to a safe location.

Programmable Logic Controller

An integrated PLC within the cabinet that features smart timing to maximize the generator's performance. It controls the valve timing and sequencing to move compressed gas throughout the system. It also has a smart feature to automatically switch between different "modes" based on the current run stages (see Chapter 7: System Operation for more about the unit's functionality).

Safety Relief Valves

The installed ASME safety relief valves add additional safety to protect component failures.

Nitrogen Tank

A nitrogen tank inside the cabinet comes with ball valves, safety relief, and a gauge.

Automatic Cut-In and Cut-Out

The generator starts and stops based on a pressure switch. Do not adjust the factory preset cut-in and out pressure without first consulting with South-Tek Systems.

Patented BlastOff® – Leak Detection System

The "BlastOff® Leak Detection" is a patented feature which sends an alarm if it detects a possible gas leak. The alarm signal can be an audible, visual, and dry contact connection to the "Building Management System (BMS)". Power cycle the unit to reset the alarm but avoid doing this without finding the cause, as it will shorten the generator's life.

AutoPurge™

Designed to cycle nitrogen continuously through the fire protection system, the AutoPurge™ consists of a ball valve, strainer, and a tunable orifice that is set based upon the capacity of the system. The device connects to a 1/2" NPT outlet on the system preferably at a remote location from the system riser, in an area where water will not collect, and is accessible (see Figure 10).

When set properly the AutoPurge™ is designed to ensure 98% minimum purity throughout the system within two (2) weeks. A convenient outlet port is provided for connection of a Quick-Check Portable® Nitrogen Purity Sensor (not provided; order separately).

N2-Blast® FPS-900-RS Specifications

- Nitrogen Purity 98.5+%
- Integrated Installation in Reliable PrePak
- Display Hours/Power on/Operating
- N₂ Storage Pressure 60-70 PSIG (±5%)
- Cabinet Port Connections 1/2" NPT Female
- Electrical 110-220V / 50-60Hz / 1Phase; 20 Amp Breaker
- Compressor Integral / Oil-Free
- Ambient Temperature 40° to 100°F
- Noise Level (dbA) < 90 dbA

Operation

The nitrogen generator uses valve sequencing to produce nitrogen. The design meets specifications of a fire protection system. Consult with South-Tek System for written approval before performing any field changes or customization. Unauthorized changes void all warranties and may cause damages or malfunctions to the system.

This section describes the major control functions and instrumentations associated with the nitrogen generators. All programs are proprietary and password protected from the factory. Do not alter any controls or instrumentations. Changes without South-Tek Systems' written consent voids the performance specifications.

Controller Modes

To utilize the buttons on the front of the controller the unit must be in "S" or "Switch" mode and unlocked. If the system is displaying "LOCK", the Mode Select Button may be pressed and held to unlock the controller (repeat this step if a system lockout is desired). To change to Switch Mode, press the Mode Select Button when the controller is unlocked until the System Mode Indicator displays "S". This mode allows access to two features:

- Alarm Simulation (5) – Hold the Alarm Simulation Button for 3 seconds or press the filter replacement reset button 3 times within 3 seconds to activate. This will simulate an alarm condition and trip the alarm dry contact in the unit for 2 seconds so that proper functioning can be confirmed.
- Filter Change Reset (0) – When a new FRP (Filter Replacement Kit) is installed, the 1000- hour filter change time must be reset. After replacing the filter elements, press and hold the Filter Change Reset Button for 7 seconds. An audible beep will confirm that the time is reset and filter alarm will be reset. (Note: this will also trigger the Customer Alarm Relay for one second)

Normal Run/Standby Mode (run/StdbY)

“Run” mode is when the FPS-900-RS is producing nitrogen and supplying it to the storage tank. The system will automatically enter “Standby” mode when the tank is fully pressurized (70 PSIG \pm 5 PSIG). It will remain in “Standby” mode until the tank pressure falls 7-10 psig.

To run the system in normal run mode:

1. Connect power to the system.
2. Open the nitrogen generator's 3-way outlet ball valve to nitrogen-out position.
3. On the nitrogen tank, open the gas inlet valve.
4. Push the On/Off toggle button on the upper right control panel to the “On” position (up) and the system will automatically turn on and start filling the storage tank with nitrogen.

To stop the system:

1. Switch the nitrogen generator's 3-way outlet ball valve to the bypass position.
2. System will automatically stop once it reaches the cut-out pressure of approximately 65-75 PSIG.
3. In the case of an emergency shut off, push the On/Off toggle button on the upper left control panel to the “Off” position. The unit will shut down immediately.

Alarm Mode

When an alarm mode is activated, it will trigger the audible buzzer, alarm contact, and flash the cause of the alarm on the screen. The customer alarm contact wiring can be viewed on the supplied wiring diagram. The customer alarm dry contact is constantly energized and will constantly illuminate the LED indicator on top of the contact. This is so when there is no power or power is lost on the system, the contact will de-energize and show a fault condition. The alarm contact has a max rating of 6A at 250VAC and 2A at 24VDC.

Bypass Mode (BPASS)

During the 30-minute fire protection piping system fill test or an issue with the generator is detected, the operator can switch the system into manual bypass mode by turning the handle on the 3-way ball valve to the bypass position. With the handle in the “Bypass Mode”, the bypass alarm triggers the audible buzzer, alarm contact, and flashes “BPASS” on the controller's 7-segment display. The alarm will turn off once the handle is back to normal run position.

BLASTOFF® Alarm Mode (B-Off)

The nitrogen generator activates a BlastOff® Alarm when it detects potential leaks or nitrogen being over-drawn. The BlastOff® Alarm will trigger the audible buzzer, alarm contact, and flash “B-OFF” on the controller's 7-segment display. Inspect and test the system for leaks and component failures. Power cycle the unit to reset the alarm but avoid doing this without finding the cause, as it will shorten the generator's life. Contact South-Tek System or the local installer for further troubleshooting.

Low System Pressure Alarm Mode (Lo-n2)

The low system pressure alarm activates when a system pressure is detected below the normal functioning limits of the nitrogen generator. This may be from an issue with the generator, a supply valve being shut off, or caused by a large leak in the fire protection system.

Power Loss Alarm Mode (-----)

The Power Loss alarm activates when the nitrogen generator loses power for any reason. This will cause the alarm contact to trigger.

Filter Replacement Alarm Mode (FILTr)

Once the generator has been running for 1000 hours or more, the filter replacement alarm will activate. Replace the filters according to Section 9 Maintenance. After replacing the filter elements, press and hold the Filter Change Reset Button for 7 seconds. An audible beep will confirm that the time is reset, and filter alarm will shut off if it is active. (Note: resetting this will also trigger the Customer Alarm Relay for one second)

Start-up Procedures

Use caution when working with pressurized gas. Always leak check every line before using the system. Note: Line leaks will cause the N2-Blast® FPS-900-RS to run excessively, shortening its life and possibly causing excessive wear on the compressor.

1. Visually inspect the unit to ensure no damage occurred during shipping and handling.
2. Check the power connection is correct.
3. Turn the 3-way ball valve on the system output to the “Bypass” position.
4. Open the inlet ball valve on the nitrogen storage tank if it is closed.
5. Push the power button on the top left of the cabinet to the “On” position (up). The air compressor will power on if the storage tank is under pressurized. If neither the compressor nor PLC display power on, check the wiring and supply power to the generator.
6. Once the system is running, the pressure gauge will increase to 65-70 PSIG within 30 minutes or less. While it is running, check the system for leaks to ensure proper functionality.
 - a. Once it reaches 65-70 PSIG, the system will enter “Standby” mode and automatically shut off the internal air compressor. Check the controller on the control panel for the “StdbY” display.
 - b. Once in standby, note the pressure reading on the tank pressure gauge. Monitor the pressure for the next 5 minutes for any loss in pressure. If there is a pressure drop, check for leaks around connection fittings, otherwise proceed to the next step.
7. Switch the 3-way ball valve on the system output to the “Nitrogen Out” position and the system will turn on and fill the storage tank with nitrogen.
8. Completely fill the storage tank and allow the nitrogen generator to go into standby mode.
9. Once in standby mode, monitor the tank pressure gauge for 5 minutes and ensure no significant leaks are in the sprinkler system.

Air Intake Filter

The integrated air compressor, of the N2-Blast® FPS-900-RS, has an air intake pre-filter. It prevents particles from entering the compressor housing and damaging internal components. Replace this filter once per year or every 1000 hours, whichever comes first. To do so, remove the pre-compressor filter cap by twisting it clockwise. Remove the old element and use a clean dry cloth to clean the filter bowl before installing the new element.

Air Filter Replacement

The particulate and coalescing filters, after the air compressor, are designed to capture particulate and moisture prior to entering the rest of the system. These filters need to be replaced once per year or every 1000 hours, whichever comes first.

Note: Annual Filter replacement kit part # FRP-007
Follow these instructions to replace filters:

1. Turn off the unit and remove the front cabinet door.
2. Locate the air filters on the bracket in the top-left of the cabinet (see Figure 11).
3. Make sure the filters are completely depressurized by checking the pressure gauge.
4. Remove both filter bowls by turning them counter-clockwise.
5. After removing the filter bowls, rinse debris out of the bowls with warm water.
6. Dry the bowls with a clean dry cloth and replace old O-rings with the ones in the kits and lubricate the seals.
7. Change the filter elements:
 - a. Particulate Element - Pull the plastic element housing out of the filter bowl. Twist off the black plastic cover and pull off the particulate element. Install the new element in the reverse order.
 - b. Coalescing Element - Twist the coalescing element counter-clockwise. Install the new element in the reverse order.
8. After replacing all elements and O-rings and cleaning the bowls, install the bowls back to their corresponding filter housings. Hand-tighten only.

After replacing the filters, check the filter bowls for leaks by turning on the unit momentarily. Turn the unit off to reinstall the front cover and then power the unit back on. Once powered up, the air compressor will turn on and the system will start producing nitrogen.

Key Contacts

Contact your local provider/installer for any questions about the performance and/or maintenance of the system. They will be best suited to answer your questions and your quickest solution on any issues you may have. If they cannot be reached, contact the manufacturer at:

South-Tek Systems, LLC.
tel (888) 526-6284 fax (910) 332-4178
Email: info@southteksystems.com

FAQS

1. Power Issues

If the N2-Blast® FPS-900-RS does not have power, the production and storage of nitrogen will become apparent once the storage pressure drops.

- Check the power cord.
- Has the building's circuit breaker or GFCI tripped? Locate the breaker and reset. If breaker continues to trip, you may have that circuit overloaded.

2. Pressure Issues

The N2-Blast® FPS-900-RS will produce and store Nitrogen (N₂) at 70 (+/-3) psig. Once the storage tank reaches 70 (+/-3) psig, the system will go into Standby Mode. When the pressure drops by about 7-10 psig, the system will go into Run Mode and begin to refill the storage tank. Contact the manufacturer or factory trained technician if system does not properly operate within these ranges

Nitrogen Pressure Check:

The pressure gauge on the storage tank should be between 60 and 70 psig. If the pressure is low, check the following:

- Check the power.
- Find out if fire protection system is being tested.
- Check for leaks throughout system.

3. Leaks

As with any gas system, only use a spray bottle on non-electrical equipment to find leaks. Fix or replace leaking fittings or old hose. Push-to-connect fittings will show bubbles and typically have up to a 5ccm acceptable leakage rate. Contact your local provider/installer for help.

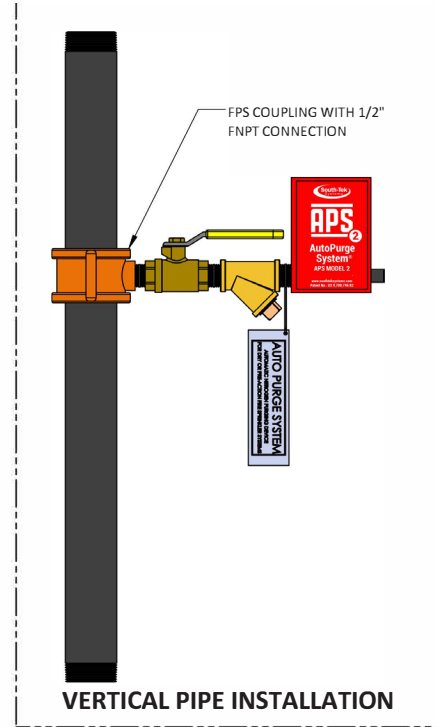
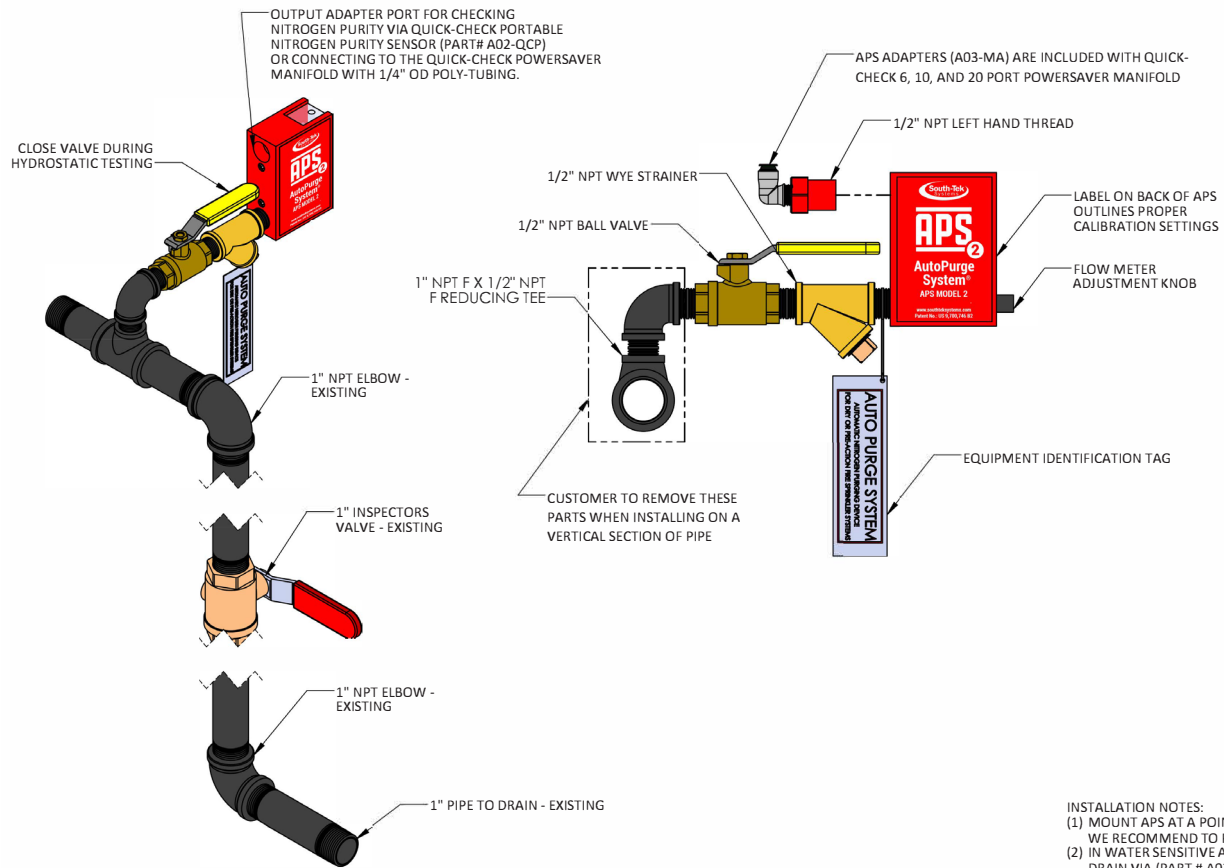

INSTALLATION NOTES:
 (1) MOUNT APS AT A POINT IN WHICH WATER WILL NOT COLLECT WITHIN THE FIRE PROTECTION PIPING. WE RECOMMEND TO PLACE THE APS AS FAR FROM THE PUMP ROOM AS POSSIBLE.
 (2) IN WATER SENSITIVE AREAS, USING THE OUTPUT ADAPTER PORT YOU CAN PLUMB THE APS TO A DRAIN VIA (PART # A03-WDK)*N2-BLAST - APS WATER DRAIN ADAPTER KIT**.

Fig. 10

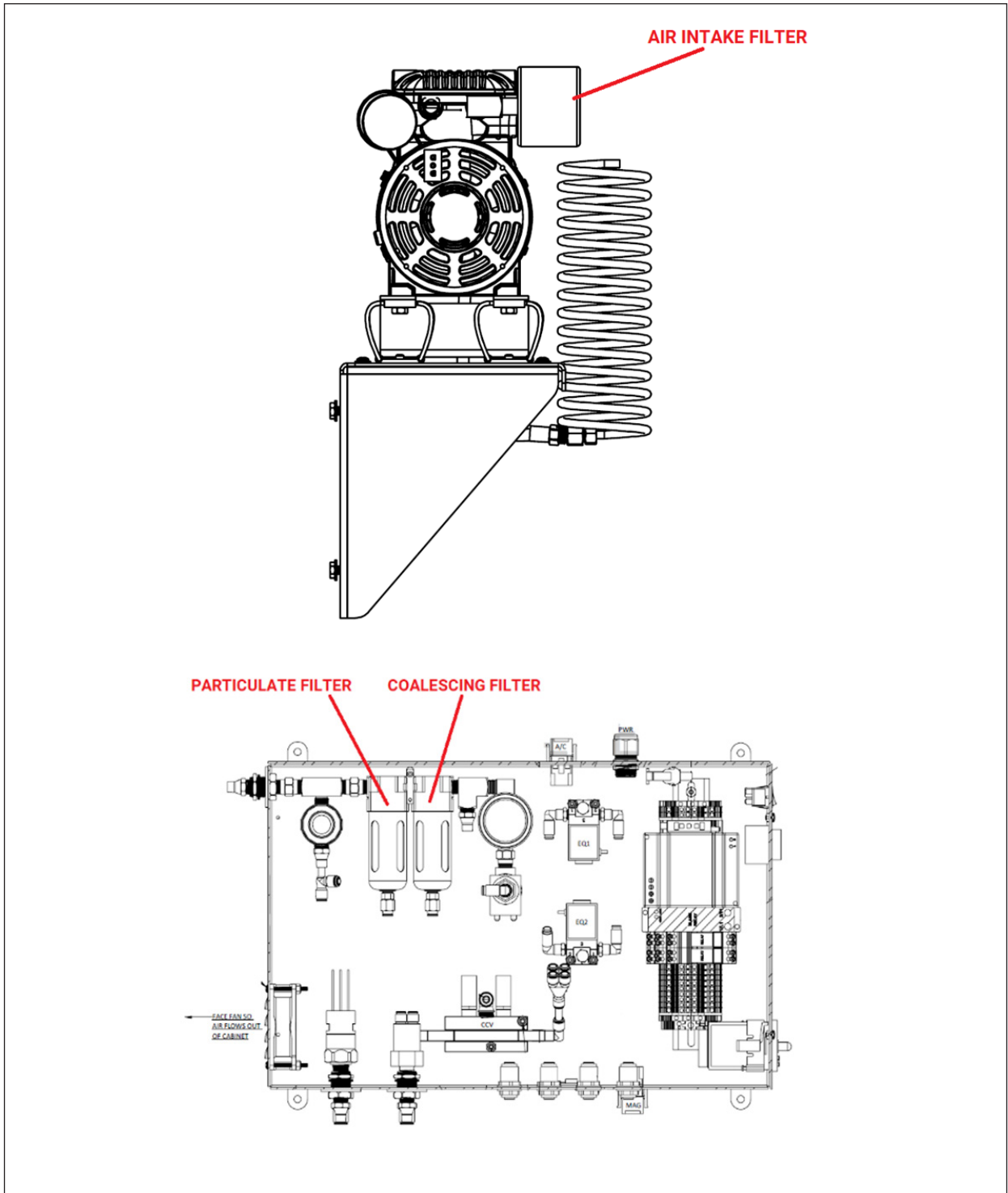

Fig. 11 - Nitrogen Generator Filter Locations

Reliable PrePaK™ Part Number Configurator (Type F with N2-Blast®)

PREPAK	SIZE ⁽¹⁾	SYSTEM TYPE	SOLENOID ⁽²⁾	RELEASE CONTROL PANEL ⁽⁴⁾	AIR COMPRESSOR ⁽⁵⁾⁽⁶⁾	GENERATOR OPTION	FUTURE
655	Select Below	2	Select Below	Select Below	Select Below	Select Below	0
	2 = 2"			0 = NO CONTROL PANEL	0 = None	8 = FPS 900 Nitrogen Generator	
	0 = 2-1/2"		1 = 175 PSI Rated	1 = POTTER 4410RC	1 = 1/2 HP 115VAC 60HZ QRM2-50115T	9 = FPS 900 Nitrogen Generator & B-1 Accelerator	
	3 = 3"		2 = 300 PSI Rated		2 = 1 HP 115VAC 60HZ QRM2-100115T		
	4 = 4"				3 = 1/2 HP 220VAC 60HZ QRM2-50220T		
	6 = 6"				4 = 1 HP 220VAC 60HZ QRM2-100220T		
	A = 2" w/SYS Side Control Valve		5 = 175 PSI Rated w/ Coil Supervisory Switch ⁽⁴⁾				
	B = 2-1/2" w/ SYS Side Control Valve						
	C = 3" w/SYS Side Control Valve						
	D = 4" w/SYS Side Control Valve						
	E = 6" w/SYS Side Control Valve						

24.

Notes:

1. Manifold size may differ from system size. Customer to confirm size of supply pipe to PrePaK™ and provide appropriate transition fittings/couplings if necessary (see Figure 1 of this document).
2. Reference technical bulletin 718 for solenoid model numbers and details.
3. cULus listed Potter Electric Signal Company CoilKeeper™.
4. If "0 = None" option is selected, customer to provide separate UL and/or FM release control panel for systems utilizing electric solenoid release. Panel must be compatible with the solenoid valve selected from above.
5. Air compressor size depends on system capacity and normal system pressure.
6. If "0 = None" option is selected, customer to provide separate, appropriately sized compressed air or nitrogen source.

Optional Seismic Kit (order separately): Reliable part number 6501200042 (30" x 33" cabinet) seismic upgrade kit is required to make the Reliable N2Blast PrePaK OSHPD compliant. One kit is required for each PrePaK (reference Caution Sheet 331).