

# Reliable

## Model CR Commercial Riser

1-1/2" through 8" (40 - 200 mm) Sizes

cULus Listed, FM Approved  
300 psi (20,7 bar) Pressure Rated

### Features

- Cast stainless steel body for 1-1/2" and 2" threaded manifolds
- Schedule 10 welded body for 2" - 8" grooved versions
- Optional schedule 40 manifold for 2" - 4" sizes
- Approved for vertical or horizontal installation

### Product Description

The Reliable Model CR Commercial Riser arrives factory assembled with water flow switch, pressure gauge, and main drain for a cost-effective system riser or floor control assembly. The Model CR is cULus listed (VEOY.EX5980) and FM approved as a unit. The main drain is available with a ball valve or Reliable Test and Drain valve, which is available with a wide selection of test orifice K-factor choices. An optional pressure relief valve kit, available in 175, 185, 210, 260, and 310 psi (12, 13, 14, 18, and 21 bar) rating, is also available.

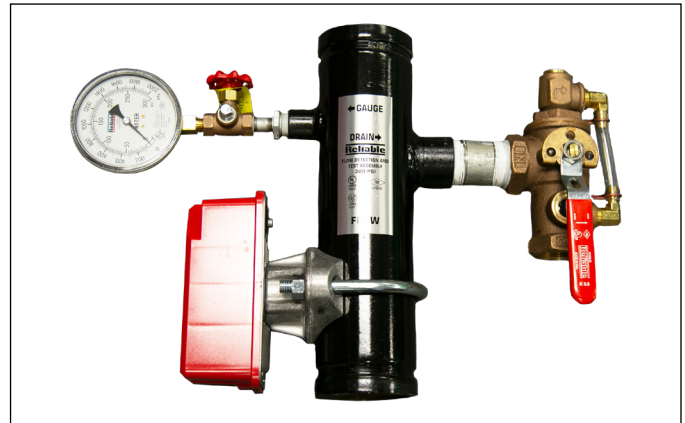

3" (80mm) welded Commercial Riser  
w/ 175psi Pressure Relief Kit and Test & Drain Valve (K5.6)

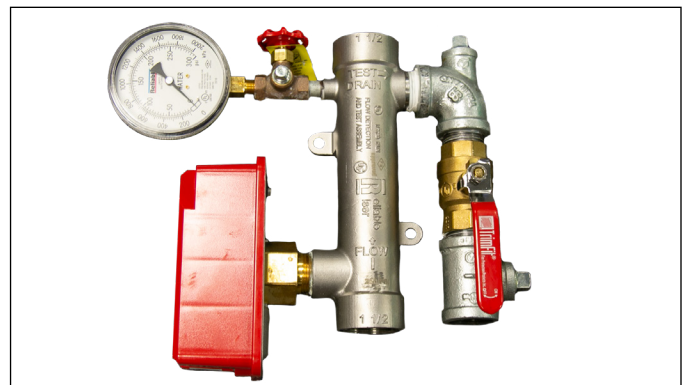

1-1/2" (40mm) Cast Stainless Commercial Riser  
w/ basic assembly

### Model CR Commercial Riser

Table A

| Valve Size    | End Connections | Material       | End-to-End Take Out | Drain Size    | K-Factor for Optional Test and Drain Valve* |
|---------------|-----------------|----------------|---------------------|---------------|---|
| 1-1/2" (40mm) | Threaded        | Cast Stainless | 8-1/4" (210mm)      | 1" (25mm)     | 2.8 (40), 4.2 (60), 5.6 (80)                |
| 2" (50mm)     | Threaded        | Cast Stainless | 8-1/4" (210mm)      | 1" (25mm)     |   |
| 2" (50mm)     | Grooved         | S10, S40 Steel | 13" (330mm)         | 1" (25mm)     |   |
| 2-1/2" (65mm) | Grooved         | S10, S40 Steel | 13" (330mm)         | 1-1/4" (32mm) | 4.2 (60), 5.6 (80), 8.0 (115), 11.2 (160)   |
| 3" (80mm)     | Grooved         | S10, S40 Steel | 13" (330mm)         | 1-1/4" (32mm) |   |
| 4" (100mm)    | Grooved         | S10, S40 Steel | 13" (330mm)         | 2" (50mm)     | 5.6 (80), 8.0 (115), 11.2 (160), 16.8 (240) |
| 6" (150mm)    | Grooved         | S10 Steel      | 13" (330mm)         | 2" (50mm)     |   |
| 8" (200mm)    | Grooved         | S10 Steel      | 13" (330mm)         | 2" (50mm)     |   |

**\*Note:** K-factor must be equal to or less than the K-factor of the smallest K-factor installed on the sprinkler system. For sprinkler systems where the smallest K-factor sprinkler on the system is greater than the largest available valve K-factor, use any valve K-factor that will provide a minimum flow of 10gpm (38 lpm) as required to operate a UL Listed Waterflow Switch.

**Model CR Commercial Riser Threaded End Assemblies (1-1/2" [40mm] & 2" [50mm])**

**Figure 1**

**THREADED ENDS ASSEMBLIES (1-1/2"(40MM) & 2"(50MM) ONLY)**

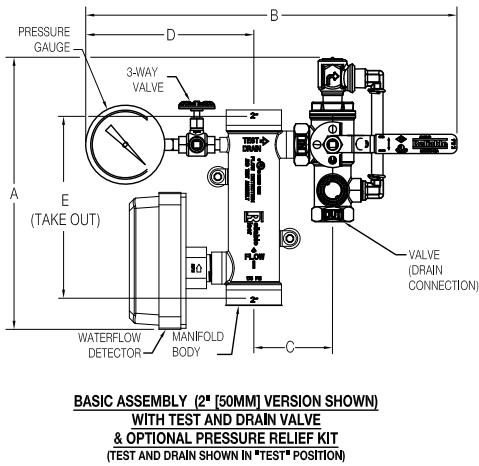
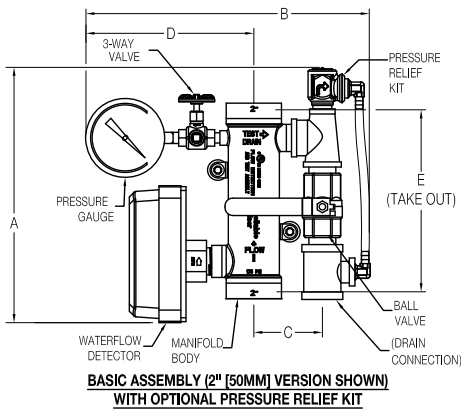

**Threaded End Basic Assembly w/ Pressure Relief Valve**

**Table B**

| End Connection             | Manifold Pipe Size in (mm) | A in (mm) | B in (mm)    | C in (mm)  | D in (mm)   | E in (mm)   | Weight lbs (kg) |
|----------------------------|----------------------------|-----------|--------------|------------|-------------|-------------|-----------------|
| Threaded Ends (See Fig. 1) | 1-1/2 (40)                 | 11 (279)  | 11-1/2 (292) | 3 (80)     | 7-3/4 (197) | 8-1/4 (210) | 8.3 (3.8)       |
|                            | 2 (50)                     | 11 (279)  | 12-1/4 (311) | 3-1/4 (83) | 8 (200)     | 8-1/4 (210) | 9.1 (4.1)       |

**Threaded End w/ Test & Drain Valve and Pressure Relief Kits**

**Table C**

| End Connection             | Manifold Pipe Size in (mm) | A in (mm)    | B in (mm)    | C in (mm)  | D in (mm)   | E in (mm)   | Weight lbs (kg) |
|----------------------------|----------------------------|--------------|--------------|------------|-------------|-------------|-----------------|
| Threaded Ends (See Fig. 1) | 1-1/2 (40)                 | 12-1/2 (318) | 11-3/4 (298) | 3 (80)     | 7-3/4 (197) | 8-1/4 (210) | 8.3 (3.8)       |
|                            | 2 (50)                     | 12-1/2 (318) | 12-1/2 (318) | 3-1/4 (83) | 8 (200)     | 8-1/4 (210) | 9.1 (4.1)       |

**Model CR Commercial Riser Grooved End Assemblies (2" [50mm] - 8" [200mm])**

**Figure 2**

GROOVED ENDS ASSEMBLIES (2" (50MM), 2-1/2" (65MM), 3" (80MM), 4" (100MM), 6" (150MM), & 8" (200MM))

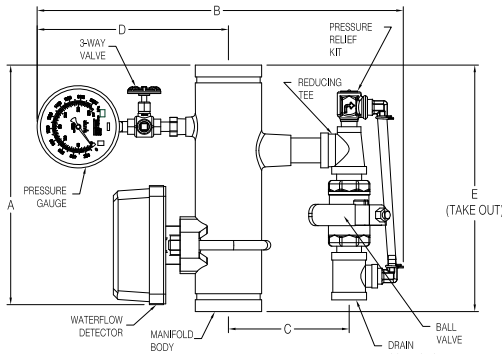

**BASIC ASSEMBLY (3" (80MM) VERSION SHOWN) WITH OPTIONAL PRESSURE RELIEF KIT**

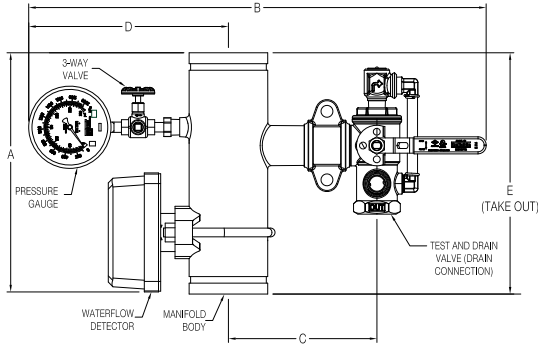

**BASIC ASSEMBLY (4" (100MM) VERSION SHOWN) WITH TEST AND DRAIN VALVE & OPTIONAL PRESSURE RELIEF KIT (TEST AND DRAIN SHOWN IN "TEST" POSITION)**

**Grooved End Basic Assembly w/ Pressure Relief Valve**

**Table D**

| End Connection            | Manifold Pipe Size in (mm) | A in (mm)    | B in (mm)    | C in (mm)    | D in (mm)   | E in (mm) | Weight lbs (kg) |
|---------------------------|----------------------------|--------------|--------------|--------------|-------------|-----------|-----------------|
| Grooved Ends (See Fig. 2) | 2 (50)                     | 12-3/4 (324) | 19 (483)     | 5-1/4 (133)  | 8 (200)     | 13 (330)  | 10.7 (4.9)      |
|                           | 2-1/2 (65)                 | 12-3/4 (324) | 19-1/2 (495) | 6-3/4 (171)  | 8-1/4 (210) | 13 (330)  | 12.9 (5.9)      |
|                           | 3 (80)                     | 12-3/4 (324) | 20-1/4 (514) | 7 (178)      | 8-1/2 (216) | 13 (330)  | 17.6 (8.0)      |
|                           | 4 (80)                     | 14 (356)     | 23-1/2 (597) | 8-1/4 (210)  | 9 (229)     | 13 (330)  | 21.3 (9.7)      |
|                           | 6 (150)                    | 14 (356)     | 26 (660)     | 9-1/4 (235)  | 10 (254)    | 13 (330)  | 26.3 (11.9)     |
|                           | 8 (200)                    | 14-1/4 (362) | 27-1/2 (699) | 10-1/4 (260) | 11 (279)    | 13 (330)  | 31.0 (14.1)     |

**Grooved End w/ Test & Drain Valve and Pressure Relief Kits**

**Table E**

| End Connection            | Manifold Pipe Size in (mm) | A in (mm)    | B in (mm)    | C in (mm)    | D in (mm)   | E in (mm) | Weight lbs (kg) |
|---------------------------|----------------------------|--------------|--------------|--------------|-------------|-----------|-----------------|
| Grooved Ends (See Fig. 2) | 2-1/2 (65)                 | 15-1/4 (400) | 19-1/2 (495) | 6-3/4 (171)  | 8-1/4 (210) | 13 (330)  | 12.9 (5.9)      |
|                           | 3 (80)                     | 15-1/4 (400) | 20-1/4 (514) | 7 (178)      | 8-1/2 (216) | 13 (330)  | 17.6 (8.0)      |
|                           | 4 (80)                     | 18-1/4 (464) | 23-1/2 (597) | 8-1/4 (210)  | 9 (229)     | 13 (330)  | 21.3 (9.7)      |
|                           | 6 (150)                    | 18-1/4 (464) | 26 (660)     | 9-1/4 (235)  | 10 (254)    | 13 (330)  | 26.3 (11.9)     |
|                           | 8 (200)                    | 18-1/4 (464) | 27-1/2 (699) | 10-1/4 (260) | 11 (279)    | 13 (330)  | 31.0 (14.1)     |

## Installation

The Model CR Commercial Riser shall be installed in accordance with NFPA 13, "Standard for the Installation of Sprinkler Systems," as well as the requirements of any authorities having jurisdiction. When installed vertically, the direction of flow shall be up through the assembly. For horizontal installations, the water flow indicator must be located to the top and drain opening to the bottom. Failure to follow installation instructions may void the warranty and/or listing of the valve. Verify compatibility of the Model CR Commercial Riser materials with the water supply and the environment where the valve will be installed prior to installation.

## Maintenance

The owner is responsible for maintaining the fire protection system in proper operating condition. Any system maintenance or testing that involves placing a system out of service may eliminate the fire protection that is provided by the fire protection system. Notify any required authorities having jurisdiction and implement appropriate precautions prior to proceeding.

The Reliable Model CR Commercial Riser shall periodically be given a thorough inspection and test. NFPA 25, "Inspection, Testing and Maintenance of Water Based Fire Protection Systems," provides minimum maintenance requirements. Replace any components found to be corroded, damaged, worn or non-operable. Increase the frequency of inspections when the valve is exposed to corrosive conditions or chemicals that could impact materials and/or operation of the assembly.

## Guarantee

For Reliable Automatic Sprinkler, Co., Inc. guarantee, terms, and conditions, visit [www.reliablesprinkler.com](http://www.reliablesprinkler.com).

## Ordering Information

Specify:

1. Reliable Model CR Commercial Riser
2. Size
3. End Connections (1 ½" and 2" threaded, 2" through 8" grooved)
4. (Optional) Schedule 40 (2" through 4" grooved end only)
5. Drain Option (Ball valve or Test and Drain valve)
6. Test orifice K-factor (if ordering Test and Drain valve)
7. (Optional) Pressure Relief Valve Kit (175, 185, 210, 260, or 310 psi [12.1, 12.8, 14.5, 17.9, or 21.4 bar])

## Notes:

1. All Model CR Commercial Riser Assemblies come with a 300 psi (20.7 bar) UL Listed and FM Approved pressure gauge for 175 psi (12.1 bar) applications. If the Model CR Commercial Riser Assembly is to be installed in a 300 psi (20.7 bar) application, please purchase a 600 psi (41.4 bar) (P/N 98248005) pressure gauge. This gauge may or may not be UL Listed and/or FM Approved at the time of purchase.
2. Unless specified at the time of ordering, pressure relief kits are NOT installed at the factory. This will facilitate hydrostatic testing of the system. When factory installed (see note 3 below) customer acknowledges that the pressure relief valve will operate during normal hydrostatic testing.
3. If required, Pressure Relief Kits may also be installed in the factory. Please contact Reliable's Customer Service Department for details.

**6A WW 0R X YY Z**

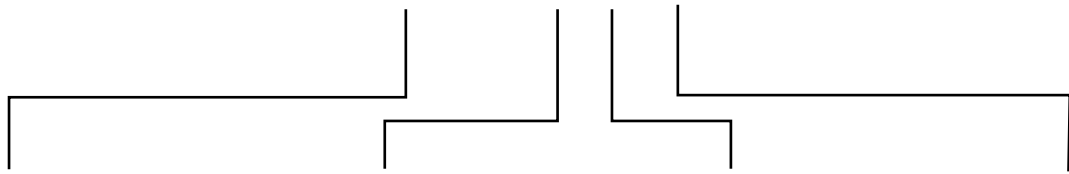

| <b>Riser Manifold Size &amp; End Connections<br/><u>WW</u></b> | <b>Waterflow Detector MFG<br/><u>X</u></b> | <b>Option*<br/>Drain Valve/K-Factor<br/><u>YY</u></b> | <b>Pressure Relief Valve<br/><u>Z</u></b> |
|--|--|---|---|
| 08 = 1-1/2" Threaded Female NPT                                | S = System Sensor                          | 00 = 1" Ball Valve Drain --                           | 0 = None                                  |
| 09 = 2" Threaded Female NPT                                    | P = Potter Flow Detector                   | 01 = 1-1/4" Ball Valve Drain --                       | 1 = 175 psi (12.1 bar)                    |
| 10 = 2" Grooved SCH10  |  | 02 = 2" Ball Valve Drain --                           | 2 = 185 psi (12.8 bar)                    |
| 11 = 2" Grooved SCH40  |  | 03 = 1" RASCO T&D Valve - K2.8                        | 3 = 210 psi (14.5 bar)                    |
| 12 = 2-1/2" Grooved SCH10                                      |  | 04 = 1" RASCO T&D Valve - K4.2                        | 4 = 260 psi (17.9 bar)                    |
| 13 = 2-1/2" Grooved SCH40                                      |  | 05 = 1" RASCO T&D Valve - K5.6                        | 5 = 310 psi (21.4 bar)                    |
| 14 = 3" Grooved SCH10  |  | 06 = 1-1/4" RASCO T&D Valve - K4.2                    |   |
| 15 = 3" Grooved SCH40  |  | 07 = 1-1/4" RASCO T&D Valve - K5.6                    |   |
| 16 = 4" Grooved SCH10  |  | 08 = 1-1/4" RASCO T&D Valve - K8.0                    |   |
| 17 = 4" Grooved SCH40  |  | 09 = 1-1/4" RASCO T&D Valve - K11.2                   |   |
| 18 = 6" Grooved SCH10  |  | 10 = 2" RASCO T&D Valve - K5.6                        |   |
| 19 = 8" Grooved SCH10  |  | 11 = 2" RASCO T&D Valve - K8.0                        |   |
|  |  | 12 = 2" RASCO T&D Valve - K11.2                       |   |
|  |  | 13 = 2" RASCO T&D Valve - K16.8                       |   |

**\*Note:** 1-1/2" and 2" manifolds have a 1" threaded drain outlet for both Test & Drain valve and ball valve drain. 2-1/2" and 3" manifolds have a 1-1/4" grooved outlet for Test & Drain valve or a 1-1/4" threaded outlet for ball valve drain. 4", 6", and 8" manifolds have a 2" grooved outlet for Test & Drain valve or 2" threaded outlet for ball valve drain.