

# Reliable®

## Model G/F1 Recessed Automatic Sprinkler

### Features

1. Highly decorative and adjustable recessed pendent sprinkler.
2. Rapid and easy installation.
3. Compensating angular ceiling alignment.
4. 3/4" (19mm) Adjustment to flush pendent position.
5. 1/2" (13mm) Adjustment for recessed position with 1/4" (6mm) minimum recess.
6. Various finishes available to match any decor.

### Listings and Approvals

1. Underwriters Laboratories Inc. (UL)
2. Underwriters' Laboratories of Canada (ULC)
3. NYC BS&A No. 587-75-SA
4. Loss Prevention Council (LPC, UK)
  - XLH, OHI and OHII Occupancies Only
5. Verband der Sachversicherer (VdS, Germany)

**Note:** Unless otherwise indicated, approvals are ordinary hazard without limitations. Small orifice sprinklers are limited to light hazard occupancies.

### Product Description

Attractively versatile is the description for the Reliable Model G/F1 Recessed Automatic Sprinkler. The Model G/F1 Recessed Sprinkler facilitates a rapid and perfect installation. When this sprinkler is used in place of any standard pendent sprinkler a more attractive and easier installation is the result.

The Model G/F1 Recessed escutcheon is highly adjustable. The two piece construction makes field installation a very easy and rapid task. The escutcheon collar threads onto the sprinkler inlet end and the sprinkler and collar are easily installed into the drop nipple using the Model RC1 Sprinkler Wrench. The escutcheon sleeve is then simply pushed onto the collar after the ceiling panels are installed. This also allows the ceiling panels to later be removed without shutting down the sprinkler system protection, thus facilitating maintenance of above ceiling services.



The impressively large adjustment in the escutcheon eliminates the expense of re-cutting drop nipples as is necessary with the non-adjustable pendent sprinklers.

This recessed sprinkler's small profile does not disrupt the overhead aesthetics, and yet one glance upward gives visual assurance of the finest in fire protection and decorative appearance of an automatic sprinkler system.

The Reliable Model G Automatic Sprinkler is the heart of the Model G/F1 Recessed Sprinkler. This sprinkler utilizes the center strut solder in compression principle of construction. The fusible alloy, captured in the cylinder of a small solder capsule by a stainless steel ball, acts as the trigger of the sprinkler. When the fusible alloys melts, the sprinkler's operating parts spring free from the sprinkler clearing the waterway and allowing the deflector to distribute the discharging water.

Reliable sprinklers should be installed in accordance with the standards of the government body or Authority Having Jurisdiction. The sprinklers must also be installed with the Model RC1 Sprinkler Wrench, specifically designed by Reliable for use with these sprinklers.

## Installation Data:

Orifice Size	Nominal K Factor		Thread	Height	Approvals	Sprinkler Identification Number (SIN)
	US	Metric				
1/2" (15mm)	5.6	80	1/2" NPT (R 1/2)	27/8" (73mm)	UL, ULC, BS&A, LPC UK, VdS	R1015
7/16" (11mm)	4.2	60	1/2" NPT (R 1/2)	27/8" (73mm)	UL, ULC, BS&A,	R1013
3/8" (9.5mm)	2.8	40	1/2" NPT (R 1/2)	27/8" (73mm)	UL, ULC, BS&A,	R1011
17/32" (13.5mm)	8.0	115	3/4" NPT (R 3/4)	215/16" (74.5mm)	UL, ULC	R1017
10mm	4.2	60	R 3/8"	73mm	VdS	R1014

## Standard Finishes

Sprinkler	Escutcheon
Bronze Chrome Plated White Polyester Coated <sup>(1)</sup>	Brass Plated Chrome Plated White Painted

<sup>(1)</sup> Only frame and deflector are coated, operating parts are chrome plated. UL Listed and BS&A Approved only.

## Ordering Information

1. Temperature rating
2. Sprinkler finish
3. Escutcheon finish
4. Orifice size
5. Inlet thread

**Note:** Sprinkler and escutcheon are packaged separately. Other finishes and colors are available on special order, consult factory for details.

## Temperature Ratings

Classification	Sprinkler Temperature		Frame Color (As Required)	Maximum Ambient Temperature	
	°F	°C		°F	°C
Ordinary	135	57	Uncolored	100	38
Ordinary	165	74	Uncolored	100	38
Intermediate	212	100	White	150	66

## Maintenance

Model G/F1 Recessed Sprinklers® should be inspected and the sprinkler system maintained in accordance with NFPA 25. Do not clean sprinklers with soap and water, ammonia or any other cleaning fluids. Remove any sprinkler that has been painted (other than factory applied) or damaged in any way. A stock of spare sprinklers should be maintained to allow quick replacement of damaged or operated sprinklers. Prior to installation, sprinklers should be maintained in the original cartons and packaging to minimize the potential for damage to sprinklers that would cause improper operation or non-operation.

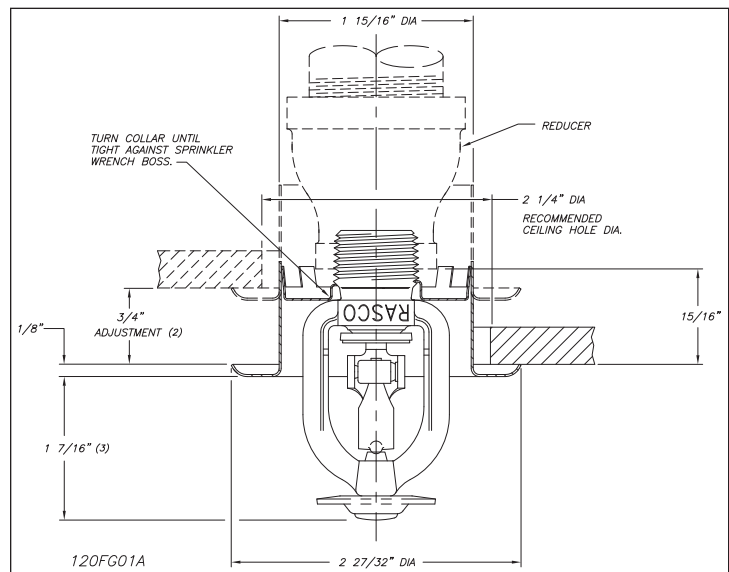

<sup>(2)</sup> A recessed sprinkler installed directly into a tee reduces the adjustment of the escutcheon.

The equipment presented in this bulletin is to be installed in accordance with the latest published Standards of the National Fire Protection Association, Factory Mutual Research Corporation, or other similar organizations and also with the provisions of governmental codes or ordinances whenever applicable.

Products manufactured and distributed by Reliable have been protecting life and property for over 90 years, and are installed and serviced by the most highly qualified and reputable sprinkler contractors located throughout the United States, Canada and foreign countries.

Manufactured by

# Reliable®

The Reliable Automatic Sprinkler Co., Inc.  
 (800) 431-1588 Sales Offices  
 (800) 848-6051 Sales Fax  
 (914) 829-2042 Corporate Offices  
 www.reliablesprinkler.com Internet Address



Revision lines indicate updated or new data.

EG. Printed in U.S.A. 10/13 P/N 99999700013