



Model F156-300 Series 300 psi (20,7 bar) Rated Standard Response Standard Spray

Model F156-300

Sprinkler Types

- Upright
- Pendent
- Recessed Pendent F1/F2/FP

Listing & Approval

1. Listed by Underwriters Laboratories, Inc. and Certified for Canada (cULus)

UL Listing Category

Sprinklers, Automatic & Open (VNIV)

Product Description

Reliable Models F156-300 Upright, Pendent and Recessed Pendent Sprinklers are high pressure rated automatic sprinklers which can handle a maximum service pressure of 300 psi (20,7 bar).

The Model F156-300 glass bulb sprinkler combines durability with the attractive low profile of a decorative sprinkler. Whether installed on exposed piping or below an office ceiling, it is functional and attractive.

The Model F1 Series Recessed Escutcheon provides convenient adjustment for Model F156-300 Sprinklers. The two-piece construction makes field installation an easy and rapid task. This also allows ceiling panels to later be removed without shutting down the fire protection system, thus facilitating maintenance of above ceiling services.

The Models F156-300 Upright, Pendent and Recessed Pendent automatic sprinklers are standard response sprinklers which utilize a 5.0mm frangible glass bulb. The glass bulb contains an accurately controlled amount of special fluid hermetically sealed inside. The other sprinkler parts are made of brass, copper or beryllium nickel.

At normal temperatures, the glass bulb contains fluid in both the liquid and vapor phases. The vapor phase can be seen as a small bubble. As heat is applied, the liquid expands, forcing the bubble smaller and smaller as the liquid pressure increases. Continued heating forces the liquid to push out against the bulb, causing the glass to shatter, opening the waterway and allowing the deflector to distribute the discharging water.



Upright



Pendent



Recessed
Pendent/F1/F2

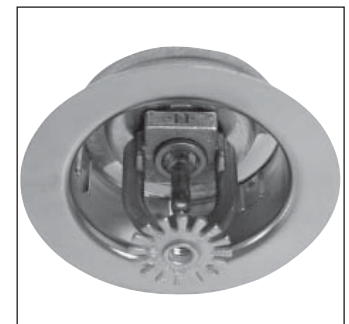

Recessed
Pendent/FP

The temperature rating of the sprinkler is identified by the color of the glass bulb.

Application

The most common applications for Model F156-300 sprinklers will be in fire protection systems for high rise buildings or where the pressure entering the sprinkler system is in excess of 175 psi (12 bar). The use of these sprinklers will provide opportunity to reduce or eliminate the need for pressure reducing valves.

Model F156-300 Upright & Pendent Sprinklers

Installation Wrench: Model D Sprinkler Wrench

Installation Data:

Sprinkler Height	Nominal Orifice Size	Thread Size	Nominal K Factor		Sprinkler Height	Sprinkler Identification Number (SIN)
			US	Metric		
Upright	1/2" (15mm)	1/2" NPT(R1/2)	5.6	80	2.25" (57mm)	RA2525 ⁽¹⁾
Pendent	1/2" (15mm)	1/2" NPT(R1/2)	5.6	80	2.25" (57mm)	RA2514 ⁽¹⁾

⁽¹⁾ cULus Listed corrosion resistant (Polyester coated) sprinklers.



Upright



Pendent

Model F156-300 Recessed Pendent Sprinkler

Installation Wrench: Model GFR2 Sprinkler Wrench

Installation Data:

Sprinkler Type	Nominal Orifice Size	Thread Size	Nominal K Factor		Sprinkler Height	Sprinkler Identification Number (SIN)
			US	Metric		
Recessed Pendent	1/2" (15mm)	1/2" NPT(R1/2)	5.6	80	2.25" (57mm)	RA2514

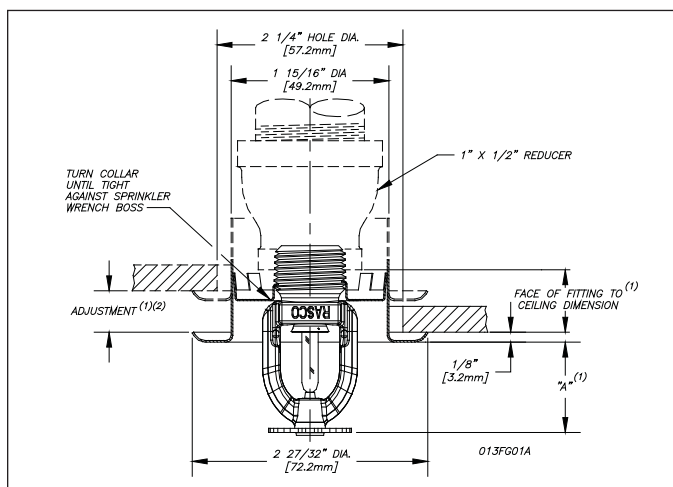

Model F156-300 F1/F2

Fig. 1

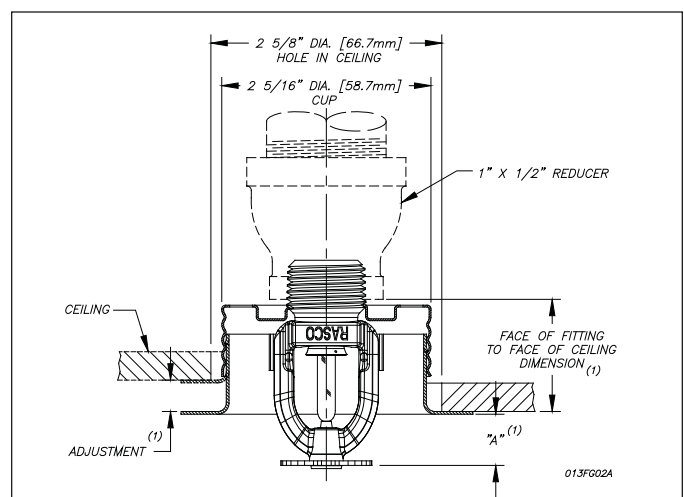

Model F156-300 FP

Fig. 2

⁽¹⁾ Refer to escutcheon data table for dimensions.

⁽²⁾ When installed directly into a tee, the escutcheon adjustment will be reduced.

Installation

Model F156-300 Sprinklers are standard response sprinklers intended for installation as specified in NFPA 13. They must be installed with the Model D Sprinkler Wrench specifically designed by Reliable for use with these sprinklers.

Model F156-300 Recessed Pendent Sprinklers are to be installed with a maximum recess of $\frac{3}{4}$ " (19mm). The Model F1, F2, and FP Escutcheons illustrated are the only recessed escutcheons to be used with Model F156-300 Pendent Sprinklers. The use of any other recessed escutcheon will void all approvals and negate all warranties.

When installing Model F156-300 Recessed Pendent Sprinklers, use the Model GFR2 Sprinkler Wrench. Any other type of wrench may damage these sprinklers.

Glass bulb sprinklers have orange bulb protectors to minimize bulb damage during shipping, handling and installation. REMOVE THIS PROTECTION AT THE TIME THE SPRINKLER SYSTEM IS PLACED IN SERVICE FOR FIRE PROTECTION. Removal of the protectors before this time may leave the bulb vulnerable to damage. RASCO wrenches are designed to install sprinklers when covers are in place. REMOVE PROTECTORS BY UNDOING THE CLASP BY HAND. DO NOT USE TOOLS TO REMOVE THE PROTECTORS.

Maintenance

The Model F156-300 Upright, Pendent and Recessed Pendent Sprinklers should be inspected and the sprinkler system maintained in accordance with NFPA 25. Do not clean sprinklers with soap and water, ammonia or any other cleaning fluid. Remove any sprinkler that has been painted (other than factory applied) or damaged in any way. A stock of spare sprinklers should be maintained to allow quick replacement of damaged or operated sprinklers. Prior to installation, sprinklers should be maintained in the original cartons and packaging until used to minimize the potential for damage to sprinklers that would cause improper operation or non-operation.

Escutcheon Data Table

Escutcheon Model	Adjustment	"A" Dimension	Face of Fitting to Ceiling or Wall Dimension
F1	Max Recessed	1 $\frac{1}{2}$ " (38.1mm)	$\frac{3}{16}$ " - $\frac{15}{16}$ "
	Min Recessed	$\frac{3}{4}$ " (19.1mm)	(5m - 24mm)
F2	Max Recessed	1 $\frac{1}{2}$ " (38.1mm)	$\frac{3}{16}$ " - $\frac{11}{16}$ "
	Min Recessed	1" (25mm)	(5m - 17mm)
FP Push-on/ Thread-off	Max Recessed	$\frac{7}{16}$ " (11mm)	1 $\frac{1}{2}$ " (38.1mm)
	Min Recessed	$\frac{15}{16}$ " (24mm)	1" (25mm)

Standard Temperature Rating

Classification	Sprinkler Temperature		Max. Ambient Temp.		Bulb Color
	°F	°C	°F	°C	
Ordinary	135	57	100°F	(38°C)	Orange
Ordinary	155	68	100°F	(38°C)	Red
Intermediate	175	79	150°F	(66°C)	Yellow
Intermediate	200	93	150°F	(66°C)	Green
High ⁽¹⁾	286	141	225°F	(107°C)	Blue
Extra High ⁽¹⁾	360	182	300°F	(149°C)	Mauve

⁽¹⁾ Not available for F1 Recessed.

Maximum Working Pressure

300 psi (20.7 bar)

100% Factory tested hydrostatically to 600 psi (41.4 bar)

Finish⁽¹⁾

Standard Finishes	
Sprinkler	Escutcheon
Bronze Chrome White or Black Polyester Coated ⁽⁵⁾	Brass Chrome White Painted
Special Application Finishes	
Sprinkler	Escutcheon
Bright Brass ⁽²⁾ Black Plated Black Paint Off White Satin Chrome Lead Plated ⁽³⁾ Wax Coated ⁽³⁾⁽⁴⁾ Wax Over Lead ⁽³⁾⁽⁴⁾	Bright Brass Black Plated Black Paint Off White Satin Chrome

⁽¹⁾ Other colors and finishes are available on special order. Consult factory for details.

⁽²⁾ 200°F (93°C) maximum.

⁽³⁾ 155°F to 200°F (68°C to 93°C) ratings only.

⁽⁴⁾ 212°F (100°C) brown wax may be used on 286°F (141°C) sprinklers when maximum ceiling temperatures do not exceed 150°F (66°C).

⁽⁵⁾ cULus Listed "Corrosion resistant" applies to SIN RA2514 (Pendent) and RA2525 (Upright) in standard black or white.

Note: Paint or any other coating applied over the factory finish will void approvals and warranties.

Ordering Information

Specify:

1. Sprinkler Model
2. Sprinkler Type
3. Orifice Size
4. Deflector Type
5. Temperature Rating
6. Sprinkler Finish
7. Escutcheon Finish (where applicable)

Note: When Model F156-300 Recessed Pendent Sprinklers are ordered, the sprinklers and escutcheons are packaged separately.

Reliable...For Complete Protection

Reliable offers a wide selection of sprinkler components. Following are some of the many precision-made Reliable products that guard life and property from fire around the clock.

- Automatic sprinklers
- Flush automatic sprinklers
- Recessed automatic sprinklers
- Concealed automatic sprinklers
- Adjustable automatic sprinklers
- Dry automatic sprinklers
- Intermediate level sprinklers
- Open sprinklers
- Spray nozzles
- Alarm valves
- Retarding chambers
- Dry pipe valves
- Accelerators for dry pipe valves
- Mechanical sprinkler alarms
- Electrical sprinkler alarm switches
- Water flow detectors
- Deluge valves
- Detector check valves
- Check valves
- Electrical system
- Sprinkler emergency cabinets
- Sprinkler wrenches
- Sprinkler escutcheons and guards
- Inspectors test connections
- Sight drains
- Ball drips and drum drips
- Control valve seals
- Air maintenance devices
- Air compressors
- Pressure gauges
- Identification signs
- Fire department connection

The equipment presented in this bulletin is to be installed in accordance with the latest published Standards of the National Fire Protection Association, Factory Mutual Research Corporation, or other similar organizations and also with the provisions of governmental codes or ordinances whenever applicable.

Products manufactured and distributed by Reliable have been protecting life and property for over 90 years, and are installed and serviced by the most highly qualified and reputable sprinkler contractors located throughout the United States, Canada and foreign countries.

Manufactured by

Reliable[®]

The Reliable Automatic Sprinkler Co., Inc.

(800) 431-1588

(800) 848-6051

(914) 829-2042

www.reliablesprinkler.com

Sales Offices

Sales Fax

Corporate Offices

Internet Address



Recycled
Paper

Revision lines indicate updated or new data.

EG. Printed in U.S.A. 10/13 P/N 9999970385