

Reliable®

Model F4FR-NF Non-Ferrous Quick Response Concealed Automatic Sprinkler for MRI Type Applications

The Non-Ferrous Concealer™

Features

1. Completely Non-Ferrous material designed for MRI rooms.
2. Laboratory tested in an MRI room environment.
3. Cup and skirt fabricated from brass.
4. Simple sturdy cover attachment.
5. Smooth aesthetic ceiling profile.
6. Available in bright brass, chrome and black plated, and white or other color painted finishes.
7. Ordinary temperature rating.
8. Threaded cover plate (Solid or Perforated) does not require clips or springs.

Listings and Approvals

Listed by Underwriters' Laboratories Inc. and UL certified for Canada (cULus).

Note: Approvals are light and ordinary hazard.

UL Listing Categories

Sprinklers, Automatic & Open
Quick Response Sprinkler

UL Guide Number

VNIV

Application

The Reliable Model F4FR-NF Non-Ferrous Concealer™ is designed specifically for MRI rooms. The sprinkler assembly was tested in a laboratory with a magnetic field up to 6 Tesla. The highest clinical magnet system commercially available today is 3 Tesla. There was no recorded influence of the magnetic field on the sprinklers. The test exposed the sprinklers to magnetic fields and field gradients that would far exceed a standard peripheral MRI room environment.

The Model F4FR-NF is a versatile, concealed, quick-response standard spray pendent sprinkler. This sprinkler offers an attractive appearance and 1/2" (13mm) cover adjustment for ease of installation. The small diameter cover plate is easily and positively attached. The cover plate is available,

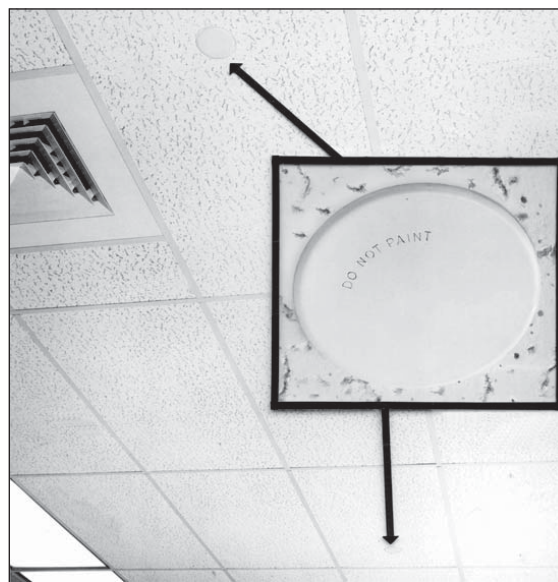
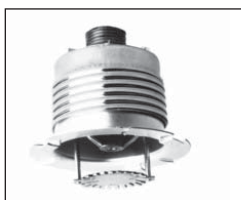

either solid or perforated, in a wide variety of colors and finishes to blend into the ceiling.

The Model F4FR-NF Non-Ferrous Concealer™ is designed for use where aesthetic appearance is important. It is a quick-response, concealed, standard spray pendent sprinkler intended for use in accordance with NFPA 13. The 1/2" (13 mm) cover plate adjustment of the Non-Ferrous Concealer™ can eliminate the need for precise cutting of drop nipples. The threaded cover plate assembly can be adjusted without tools to fit accurately against the ceiling. The fire protection system need not be shut down to adjust or remove the cover plate assembly.

Product Description

The Model F4FR-NF Non-Ferrous Concealer™ is a quick-response sprinkler that uses either a 135°F (57°C) or a 155°F (68°C) 3mm diameter glass bulb in a standard style sprinkler frame with a drop-down deflector. This assembly is recessed into the ceiling and concealed by a flat cover plate. The cover plate and sprinkler cup assemblies are attached using a strong threaded engagement. This threaded engagement provides 1/2" (13mm) of cover adjustment. The cover plate is attached to the skirt using 135°F (57°C) ordinary temperature classification solder. When the ceiling temperature rises, the solder holding the cover plate fuses, thus releasing the plate and exposing the sprinkler inside. The subsequent shattering of the sprinkler bulb opens the waterway and causes the deflector to drop into position to distribute the discharging water. Any secure engagement between the cover plate and cup will assure that the drop-down deflector is properly located below the ceiling.

Installation

Do not install The Non-Ferrous Concealer™ in ceilings which have positive pressure in the space above. In addition, inspect all sprinklers after installation to ensure that both the gap between the cover plate and ceiling and the four (4) slots in the cup are open and free from any air flow impediment.

After a 2⁵/₈" diameter hole is cut in the ceiling, the sprinkler is to be installed with the Model G4 Wrench. When installing a sprinkler, the wrench is first positioned into the sprinkler/cup assembly until two wrench tangs fully engage drive slots in the top of the cup (there are two pairs of drive slots in the cup). The sprinkler is then tightened into the pipe fitting to a torque of 8 to 18 ft-lbs (11 to 24 N-m). When inserting or removing the wrench from the sprinkler/cup assembly care should be taken to prevent damage to the sprinkler. DO NOT WRENCH ON ANY OTHER PART OF THE SPRINKLER/CUP ASSEMBLY.

Maintenance

The Model F4FR-NF should be inspected and the sprinkler system maintained in accordance with NFPA 25. Do not clean sprinklers with soap and water, ammonia or any other cleaning fluids. Replace any sprinkler or cover plate that has been painted (other than factory applied) or damaged in any way. A stock of spare sprinklers should be maintained to allow quick replacement of damaged or operated sprinklers. Prior to installation, sprinklers should be maintained in the original cartons and packaging to minimize the potential for damage to sprinklers that would cause improper operation or non-operation.

Engineering Specification

Sprinklers shall be cULus Listed, non-ferrous, quick response concealed pendent sprinklers specifically designed and tested for use in MRI type applications, and able to withstand exposure to a magnetic field of up to 6 Tesla. The sprinkler frame and cover plate assembly shall be of all brass construction, including the drop-down deflector and sprinkler cup assembly. The water seal shall consist of a Teflon film coated Belleville spring washer and bulb/machined cup assembly utilizing a 3 mm glass bulb thermal element. Sprin-

Temperatures Ratings

Classification	Sprinkler	Cover Plate	Max. Ceiling Temp.
Ordinary	135°F/57°C 155°F/68°C	135°F/57°C	100°F/38°C

Installation Data

Total Adjustment	Nominal Orifice	Nominal K Factor		Thread	Approval	Sprinkler Identification Number (SIN)
		US	Metric			
1/2" (13mm)	1/2" (15mm)	5.6	80	1/2" NPT (R1/2)	cULus	RA0212

klers shall have a 1/2" NPT with a nominal K-factor of 5.6 (80 metric). Sprinklers shall have a temperature rating of [135°F (57°C)][155°F (68°C)]. Cover plates shall be specifically listed for use with the sprinklers and shall have a temperature rating of 135 °F (57 °C). Sprinkler Cover plates shall be capable of providing 1/2" of adjustment and shall attach to the sprinkler cup by a strong threaded engagement. The sprinkler cup shall be reinforced with an attached brass wrenching plate to protect the sprinkler cup from damage during installation. Sprinklers shall be cULus Listed for Light Hazard and Ordinary Hazard occupancies. Cover plate finish shall be: [Chrome] [White] [Specialty – specify]. Quick Response Concealed Pendent Sprinklers shall be the Reliable Non-Ferrous Concealer™, SIN RA0212.

Ordering Information

Specify

1. Sprinkler Model
2. Cover Plate Finish

Cover Plate Finishes⁽¹⁾

Standard Finishes
Chrome
White
Special Application Finishes ⁽²⁾
Bright Brass
Finished Bronze
Black Plating
Black Paint
Off White
Satin Chrome

⁽¹⁾ Other finishes and colors are available on special order. Consult factory for details. Coverplate custom paint is semi-gloss, unless specified otherwise.

⁽²⁾ For the perforated style cover plate, consult factory for availability on these and other custom finishes.

Installation Wrench

Model G4 Sprinkler Wrench

Note: Paint or any other coatings applied over the factory finish will void all approvals and warranties.

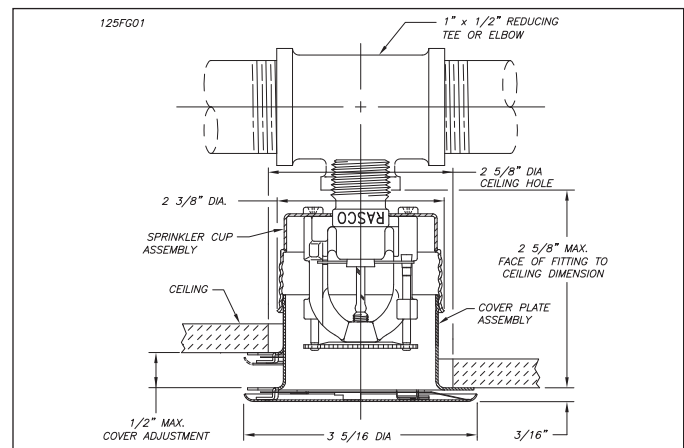

The equipment presented in this bulletin is to be installed in accordance with the latest published Standards of the National Fire Protection Association, Factory Mutual Research Corporation, or other similar organizations and also with the provisions of governmental codes or ordinances whenever applicable.

Products manufactured and distributed by Reliable have been protecting life and property for over 90 years, and are installed and serviced by the most highly qualified and reputable sprinkler contractors located throughout the United States, Canada and foreign countries.

Manufactured by



Reliable Automatic Sprinkler Co., Inc.

(800) 431-1588

(800) 848-6051

(914) 829-2042

www.reliablesprinkler.com

Sales Offices

Sales Fax

Corporate Offices

Internet Address



Recycled Paper

Revision lines indicate updated or new data.

EG. Printed in U.S.A. 04/15

P/N 9999970241