

Y Strainer Flanged x Grooved

REL-STR-FG

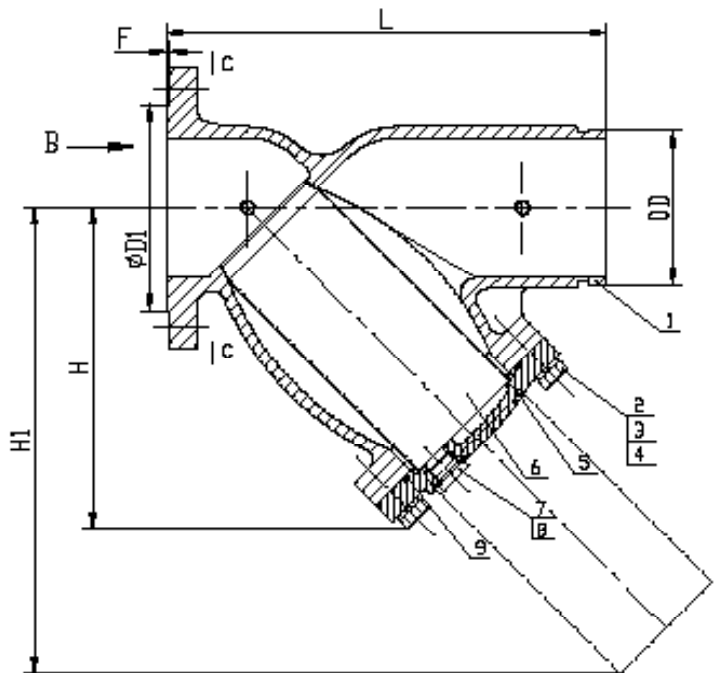

Working pressure:
21 BARS/300 PSI

Working temperature:
-10°C to 120°C

FBE coating internally
and externally RAL3002

Flanged x Grooved End:
ANSI B16.1 CL125/150/250
BS10 Table D/E, EN1092-2
PN10/PN16/PN25
AWWA C 606
Grooved ends to suit ANSI/BS
standard pipe.

Material Lists:

No.	Name	Material	DWG No.
1	Body	Ductile Iron ASTM A536 65-45-12	YH-MY125UL-01FG-00
2	Bolt	Gr 8.8	ASME B16.20-1998
3	Washer	Gr 8.8	ASME B18.2.1-1996
4	Washer	Gr 8.8	GB/T 95-1985
5	Cover	Ductile Iron ASTM A536 65-45-12	YH-MY125-02-00
6	Screen	Stainless Steel SS304	YH-MY125UL-03-00
7	Plug	Carbon Steel Q235+Zn	YH-MY50-300-04-00
8	Plug Seal	45#+EPDM	YH-MY50-300-05-00
9	O Ring	EPDM	GB/T 3452.1-1992
10	Test Screw	ASTM B16	YH-MY50-300-06-00

Size	DN50	DN65	DN80	DN100	DN125	DN150	DN200	DN250	DN300
Measured loss at 15fps (4.6m/s)	7.22 psi	5.89 psi	8.24 psi	5.88 psi	7.63 psi	4.82 psi	5.83 psi	7.25 psi	5.73 psi



R0027B

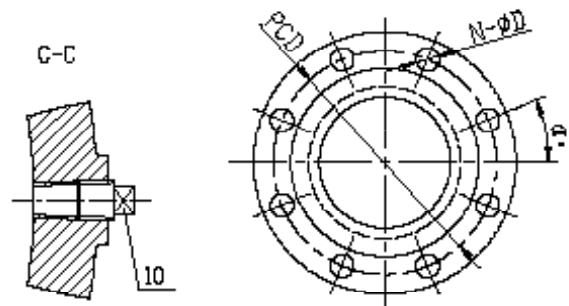

Dimensions (mm/inches):

Size	L	H	H1	ØD	Blow off plug	ANSI 150				
						PCD	N-ØD	a°	ØD1	F
DN50	203/7.99	130/5.20	195/7.68	60.3/2.37	3/4"	120.7	4-Ø19	45	92.1	2
DN65	254/10.00	158/6.22	240/9.45	73.0/2.87 (76.1/3)	3/4"	139.7	4-Ø19	45	104.8	2
DN80	260/10.24	175/6.89	270/10.63	88.9/3.50	3/4"	152.4	4-Ø19	45	127	2
DN100	308/12.13	202/7.95	320/12.60	114.3/4.50	3/4"	190.5	8-Ø19	22.5	157.2	2
DN125	398/15.67	290/11.42	425/16.73	139.7/5.5 (141.3/5.56)	3/4"	215.9	8-Ø22.2	22.5	185.7	2
DN150	472/18.58	334/13.15	495/19.49	165.1/6.5 (168.3/6.63)	3/4"	241.3	8-Ø22.2	22.5	215.9	2
DN200	550/21.65	391/15.39	570/22.44	219.1/8.63	3/4"	298.5	8-Ø22.2	22.5	269.9	2
DN250	654/25.75	460/18.11	700/27.56	273/10.75	3/4"	361.9	12-Ø25.4	15	323.8	2
DN300	762/30.00	590/23.23	840/33.07	323.9/12.75	3/4"	431.8	12-Ø25.4	15	381	2

Part numbers:

Description	Size	Part Number
RASCO Y Strainer Flanged/Grooved ANSI 150	DN50	7U99002129
RASCO Y Strainer Flanged/Grooved ANSI 150	DN65	7U99002130
RASCO Y Strainer Flanged/Grooved ANSI 150	DN80	7U99002131
RASCO Y Strainer Flanged/Grooved ANSI 150	DN100	7U99002132
RASCO Y Strainer Flanged/Grooved ANSI 150	DN125	7U99002133
RASCO Y Strainer Flanged/Grooved ANSI 150	DN150	7U99002134
RASCO Y Strainer Flanged/Grooved ANSI 150	DN200	7U99002135
RASCO Y Strainer Flanged/Grooved ANSI 150	DN250	7U99002136
RASCO Y Strainer Flanged/Flanged ANSI 150	DN300	7U99002137

R0027B