



### Material List

No.	Component	Material
1	Upper shaft sealing nut	WCB ASTM A216
2	Shaft seal	EPDM ASTM D2000
3	Body	DI ASTM A536
4	Upper shaft	SS416 ASTM A582
5	Disc	DI + EPDM
6	Lower shaft	SS416 ASTM A582
7	Lower shaft sealing nut	WCB ASTM A216
8	Stem bushing (2.5" to 6")	PTFE ASTM D4894
8	Stem bushing (8")	C95400 ASTM B148
9	Gear box	

### Carried Standard

Max Working Pressure:	300PSI / 21.4 Bar
Design Standard:	API609
Groove Standard:	ANSI/AWWA C606
Top Flange Standard:	ISO 5211
Test Standard:	API 598

Design and materials are subject to change without notice.



### Wiring Diagram

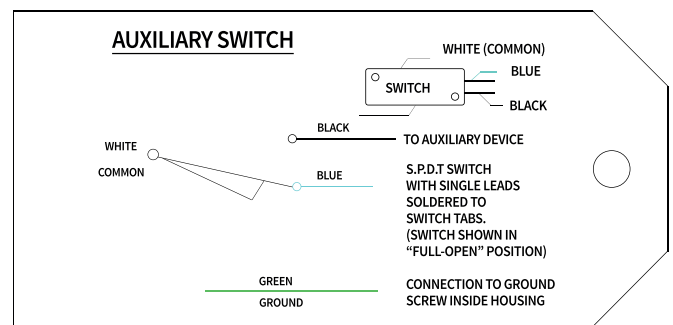
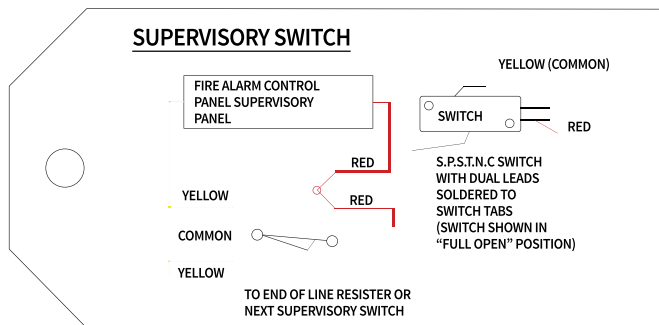

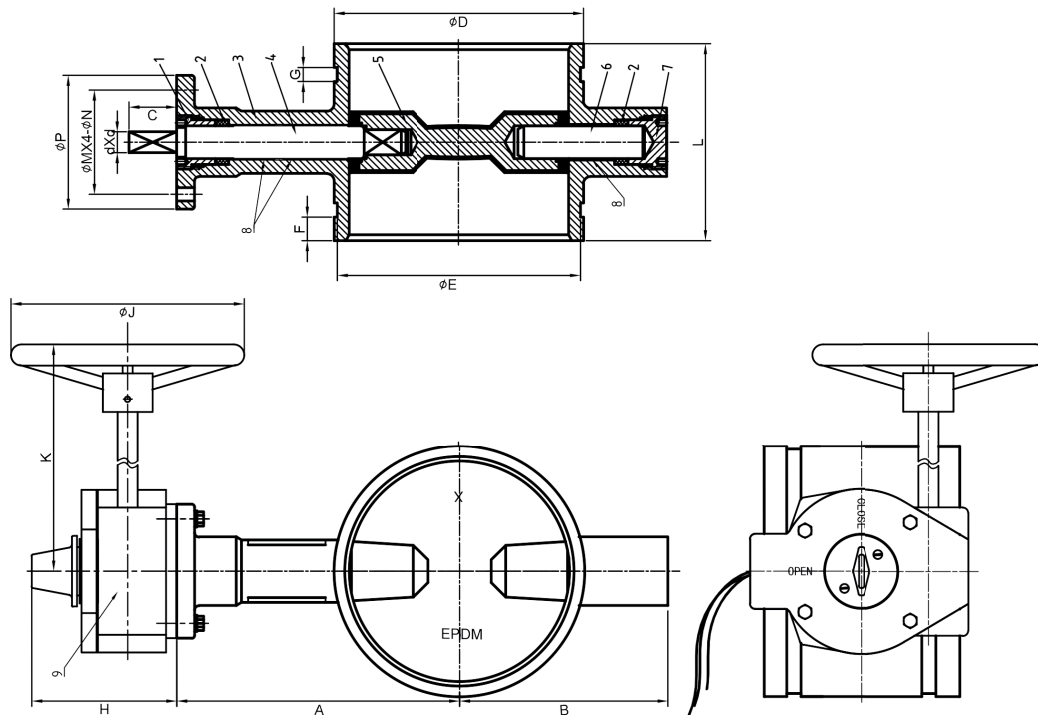

### Dimensions (mm)

DN	A	B	C	D	E	F	G	H	K	J	P	M	N	d	L	Weight	
65 (2.5")	125	95	32	73	69.1	15.9	7.9	111	153	218	152	90	70	9	10	96.4	8.4kg
				76.1	72.3												
80 (3")	140	100	32	88.9	84.9	15.9	7.9	111	153	218	152	90	70	9	11	97	9.1kg
100 (4")	160	100	32	114.3	110.1	15.9	9.5	111	153	218	152	90	70	9	14	115.1	10.1kg
165 (6")	190	140	32	165.1	160.9	15.9	9.5	111	153	218	200	90	70	9	16	132.4	14.7kg
				168.3	164												
200 (8")	230	175	32	219.1	214.4	19	11.1	126	210	232	290	125	102	12	16	147.4	28.7kg
				216.3	211.6												
250 (10")	260	200	45	273	268.3	19	12.7	126	232		290	125	102	12	22	159	37.4kg
300 (12")	300	240	45	324	318.3	19	12.7	161	252		350	150	125	14	24	165	72.7kg

### Ordering Information

Description	Size (mm)	Part Number
Butterfly Valve FM/UL Grooved 300 PSI (Rasco) (73mm)	65 (2.5")	7U99002223
Butterfly Valve FM/UL Grooved 300 PSI (Rasco) (76mm)	65 (2.5")	7U99002224
Butterfly Valve FM/UL Grooved 300 PSI (Rasco)	80 (3")	7U99002225
Butterfly Valve FM/UL Grooved 300 PSI (Rasco)	100 (4")	7U99002226
Butterfly Valve FM/UL Grooved 300 PSI (Rasco) (165mm)	165 (6")	7U99002228
Butterfly Valve FM/UL Grooved 300 PSI (Rasco) (168mm)	168 (6")	7U99002227
Butterfly Valve FM/UL Grooved 300 PSI (Rasco)	200 (8")	7U99002229
Butterfly Valve UL Grooved 300 PSI (Rasco) *	250 (10")	7U99002230
Butterfly Valve UL Grooved 300 PSI (Rasco) *	300 (12")	7U99002231

\* 10" and 12" are only UL Listed