



## Model BFG-300 Supervised Butterfly Valve Grooved

cULus Listed, FM Approved  
300 psi (20.7 bar)

### Product Description

The Reliable Model BFG-300 Supervised Butterfly valves are cULus Listed and FM Approved for fire protection systems. Reliable Supervised Butterfly Valves valves have AWWA C606 grooved end connections. They are available in 2-1/2" (65mm), 3" (80mm), 4" (100mm), 6" (150mm), and 8" (200mm) nominal sizes. The valves are listed for 300 psi (20.7 bar) working pressure. The maximum working temperature for the valves is 250°F (120°C).

### Maintenance

The owner is responsible for maintaining the fire protection system in proper operating condition. Any system maintenance or testing that involves placing a control valve out of service will eliminate the fire protection that is provided by the fire protection system.

The Reliable Supervised Closed Butterfly valves and associated equipment shall periodically be given a thorough inspection and test. NFPA 25, "Inspection, Testing and Maintenance of Water Based Fire Protection Systems," provides minimum maintenance requirements.

### Guarantee

For Reliable Automatic Sprinkler Co., Inc. guarantee, terms, and conditions, visit [www.reliablesprinkler.com](http://www.reliablesprinkler.com).



Supervised Grooved Butterfly Valve - Supervised Open



Supervised Grooved Butterfly Valve - Supervised Closed

### Ordering Information

Specify the following when ordering:

#### Model BFG-300 Butterfly Valve Supervision

- Valve Supervised Open (yellow indicator)
- Valve Supervised Closed (white indicator)

#### Valve Size

- 2-1/2" (65mm)
- 3" (80mm)
- 4" (100mm)
- 6" (150mm)
- 8" (200mm)

### Reliable Supervised Butterfly Valve Wiring Diagram - Valve in Supervised Position

Figure 1

Supervised Normally Open Valve

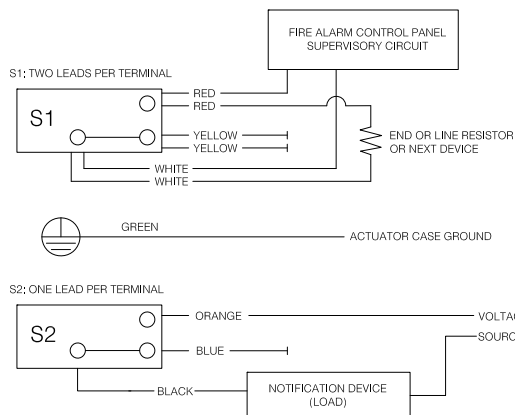

Supervised Normally Closed Valve

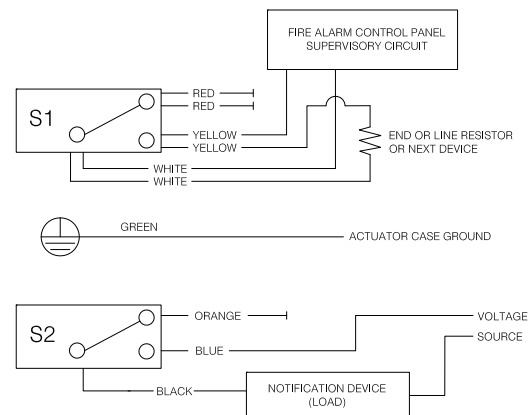

**Notes:** Rated: 5A-1/6HP-125/250VAC  
0.5A - 125VDC  
0.25A - 250DC

## Reliable Model BFG-300 Supervised Butterfly Valve Grooved

### Technical Specifications

**Pressure Rating:**  
300 psi (20.7 bar)

### Material Specifications

**Body:** Ductile Iron ASTM A-536 Nylon-11 Coated  
**Disc:** ASTM A-536 EPDM Encapsulated  
**Upper and Lower Stems:** AISI 420-SS  
**Housing:** ASTM A-536  
**Hand Wheel:** ASTM A-536  
**Flag Indicator:** ASTM A-536  
**Shear Pin:** ASTM A-510  
**Segment Gear:** ASTM B-148 or B-584  
**Housing Gasket:** EDPM Grade E  
**O-Ring:** EDPM Grade E

### Specifications

Groove Inlet: AWWA C 606

### Listings and Approvals

cULus Listed  
 FM Approved



Reliable Supervised Butterfly Valve Specification and Dimensions

Figure 2

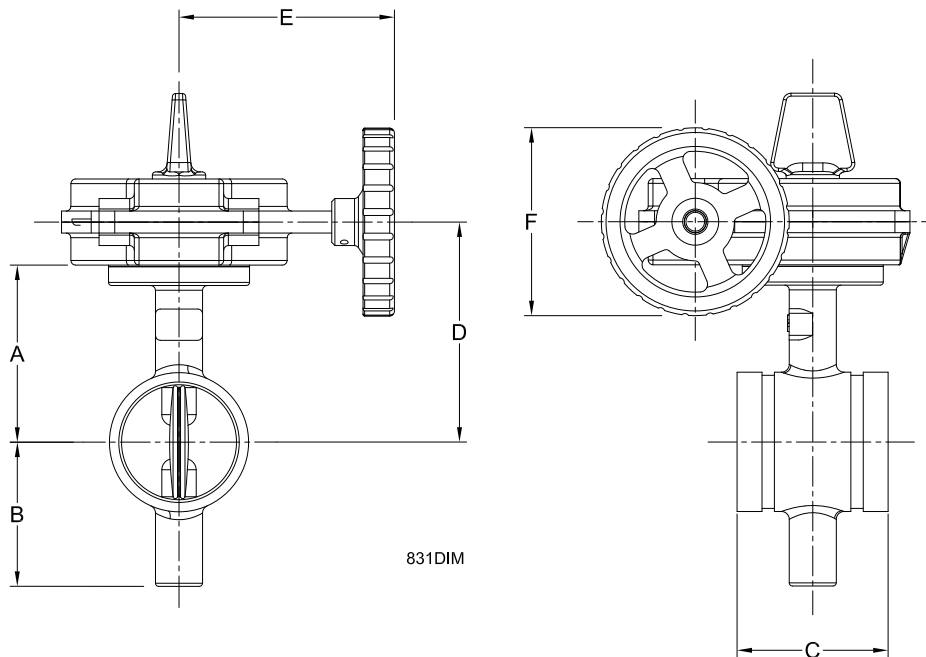

### Dimensions - in. (mm)

Table B

Valve Size	A	B	C	D	E	F
2-1/2" (65)	4-1/8 (105)	3-5/8 (92)	3-13/16 (96)	5-1/3 (135)	5-5/16 (135)	5 (128)
3" (80)	4-7/16 (112)	3-11/16 (95)	3-13/16 (96)	5-5/8 (142)	5-5/16 (135)	5 (128)
4" (100)	5-11/16 (145)	4-1/4 (108)	4-1/2 (115)	6-15/16 (175)	5-5/16 (135)	5 (128)
6" (150)	7 (179)	5-11/16 (146)	5-3/16 (132)	8-1/4 (209)	7-5/8 (193)	8-5/8 (220)
8" (200)	8 (204)	6-11/16 (170)	5-13/16 (147)	9-1/4 (234)	7-5/8 (193)	8-5/8 (220)