

Reliable®

Model REL-50GG Swing Check Valve

cULus Listed, FM Approved
365 psi (25 bar)

Product Description

Reliable Model REL-50GG single swing check valves are low friction loss check valves approved for use in fire protection systems. These are used in fire protection systems to allow water-flow in one direction only. Typical applications include connections between public water supplies and private fire systems, at the discharge from fire pumps, at gravity tank connections and at fire department pumper connections.

Installation

The Reliable Model REL-50GG Swing Check Valve shall be installed in accordance with NFPA 13, "Standard for the Installation of Sprinkler Systems," as well as the requirements of any authorities having jurisdiction. Verify compatibility of the Model REL-50GG Check Valve materials with the water supply and the environment where the valve will be installed prior to installation. Do not apply lubricants, sealants, or other chemicals to the clapper seal or seat.

Note: Model REL-50GG may be damaged by excessively turbulent water flow. Model REL-50GG should be installed a reasonable distance from pipe transitions, such as pumps, elbows, expanders, reducers, or similar devices. Typical piping practices suggest a minimum distance of five times the pipe diameter for general use.

Maintenance

The owner is responsible for maintaining the fire protection system in proper operating condition. Any system maintenance or testing that involves placing a control valve out of service will eliminate the fire protection that is provided by the fire protection system.

The Reliable Model REL-50GG Swing Check valves and associated equipment shall periodically be given a thorough inspection and test. NFPA 25, "Inspection, Testing and Maintenance of Water Based Fire Protection Systems," provides minimum maintenance requirements.



Swing Check Valve

Guarantee

For Reliable Automatic Sprinkler Co., Inc. guarantee, terms, and conditions, visit www.reliablesprinkler.com.

Ordering Information

Specify the following when ordering:

Model REL-50GG Swing Check Valve Valve Size

- 2" (50mm)
- 2-1/2" (65mm)
- 76mm
- 3" (80mm)
- 4" (100mm)
- 6" (150mm)
- 165mm
- 8" (200mm)
- 10" (250mm)
- 12" (300mm)

Model REL-50GG Swing Check Valve

Technical Specifications

Pressure Rating:
365 psi (25 bar)

Material Specifications

Body: Ductile Iron ASTM A536 65-45-12
Seat: Bronze ASTM B62 C83600
Clapper: Q235+SS304+EPDM
Clapper Arm: Stainless Steel ASTM A351 CF8
Washer: Stainless Steel AISI 304
Hexagonal Slot Thin Nut: Stainless Steel AISI 304
Split Pin: Stainless Steel AISI 304

Listings and Approvals

cULus Listed
FM Approved

End Connections

AWWA C606
VDS2100/AS2638.2



Dimensions

Figure 1

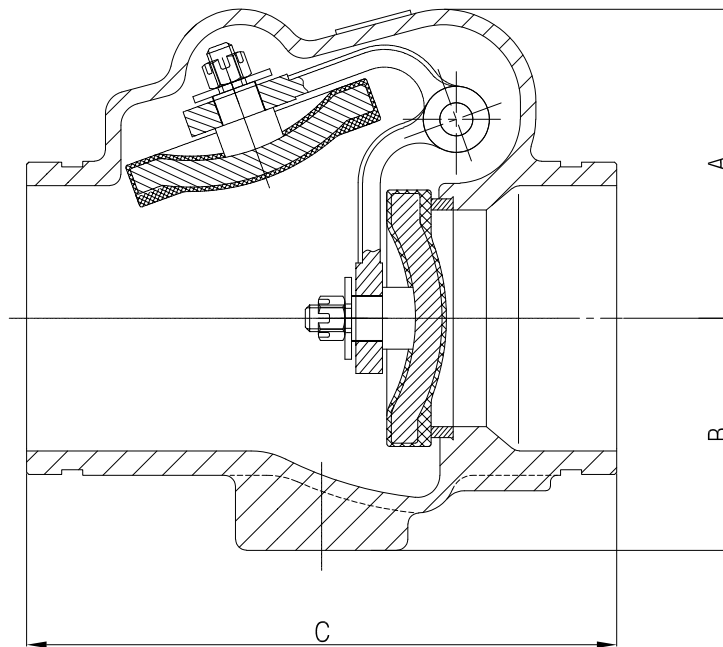

Dimensions - in. (mm)

Table A

Nominal Valve Size	A	B	C
2" (50)	3-3/8" (85)	2-1/2" (65)	6-5/8" (169)
2-1/2" (65)	3-3/4" (95)	2-11/16" (68)	8" (203)
76mm	3-3/4" (95)	2-11/16" (68)	8" (203)
3" (80)	4-2/4" (108)	3-1/8" (80)	8-3/8" (213)
4" (100)	4-13/16" (122)	3-5/16" (90)	9-5/8" (245)
6" (150)	6-1/4" (158)	4-3/4" (120)	11-1/2" (292)
165mm	6-1/4" (158)	4-3/4" (120)	11-1/2" (292)
8" (200)	10-5/8" (269)	6" (150)	14" (356)
10" (250)	11-11/16" (297)	6-11/16" (170)	17" (432)
12" (300)	14-5/8" (372)	7-11/16" (195)	19-1/2" (495)

