



Model CVE Check Valve & Riser Check Valve

cULus Listed, FM Approved
300 psi (20.7 bar) Rated Pressure

Features

- Grooved End Connections.
- Removable faceplate.
- Approved for horizontal and vertical installation.
- Non-slamming, spring loaded clapper to minimize water hammer.

Product Description

The Reliable Model CVE Check Valve and Riser Check Valve is a general purpose fire protection system check valve. The valves have grooved end connections and a removable face plate, and are approved for either vertical or horizontal (hinge pin up) installation. The Model CVE check valve incorporates a bronze seat and an EPDM-faced clapper.

The Model CVE Riser Check Valve is designed for use as a wet system riser or zone control, and includes supply and system-side pressure gauges and a two-inch ball valve main drain. The Riser Check trim may be ordered separately or factory assembled.



Model CVE Check Valve

Model CVE Check Valves & Riser Check Valves

Table A

Valve Size	Take Out	Friction Loss (Eq. Length)	Weight (Valve Only)	Weight (Riser Trim)
4" (100mm)	11.75" (299mm)	17' (5.2m)	60 lbs. (27.2kg)	9 lbs (4.1kg)
6" (150mm)	13.5" (343mm)	27' (8.2m)	75 lbs. (34kg)	
165mm	13.5" (343mm)	27' (8.2m)	75 lbs. (34kg)	
8" (200mm)	14.5" (368mm)	29' (8.8m)	126 lbs. (57.2kg)	

Model CVE Valve Components (refer to Table B)

Figure 1

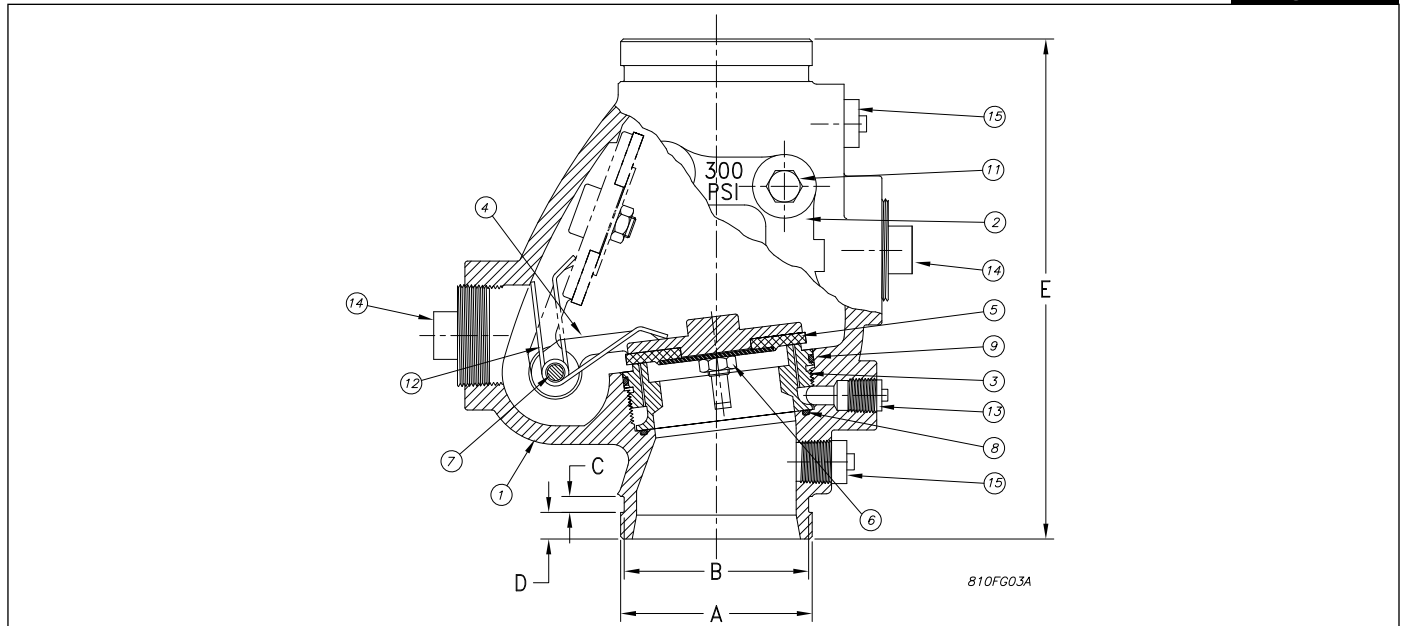

Model CVE Valve Components (refer to Figure 1)

Table B

Item No.	Part Name	Material	Quantity	Part Number			
				4" (100mm)	6" (150mm)	165mm	8" (200mm)
1	Valve Body	Gray Iron, ASTM-A48, Class 30A	1	91006015	91006017	91006020	91006019
2	Cover	Gray Iron, ASTM-A48, Class 30A	1	92116014	92116016	92116017	92116018
3	Seat	Bronze, C83600	1	96016114	96016116	96016116	96016118
4	Clapper & Bushing Assembly	Ductile Iron, ASTM-A536 (Clapper) & Brass C36000 (Bushing)	1	71020424	71020426	71020426	71020428
5	Facing & Clamping Ring Assembly	EPDM (Facing) & Stainless Steel, 304 (Clamping Ring)	1	93416104	93416106	93416106	93416108
6	Clamping Ring Nut (4" (100mm) only)	Stainless Steel, 304	1	94906124	N/A	N/A	N/A
	Clamping Ring Screw	Stainless Steel, 304	4 (6" & 165mm), 5 (8")	N/A	95606126	95606126	95606126
7	Hinge Pin	Brass C36000	1	95006124	95006126	95006126	95006128
8	O-Ring	Nitrile (Buna-N)	1	65436124	65436126	65436126	65436128
9	O-Ring	Nitrile (Buna-N)	1	95446124	95446126	95446126	95446128
10	Cover Gasket (Not Shown)	Neoprene	1	93706124	93706126	93706126	93706128
11	Cover Bolt, 1/2"-13 x 1-1/2"	Steel	6	91106124	N/A	N/A	N/A
	Cover Bolt, 5/8"-11 x 1-3/4"	Steel	6	N/A	91106126	91106126	91106126
12	Spring	Bronze, C51000	1	96406124	96406124	96406124	96406124
13	Pipe Plug, 1/2" (One Not Shown)	Malleable Iron	2	98604406	98604406	98604406	98604406
14	Pipe Plug, 2"	Malleable Iron	2	95206104	95206104	95206104	95206104
15	Pipe plug, 3/4"	Malleable Iron	2	98614401	98614401	98614401	98614401

Service Kits

Service kits are available for routine servicing of the valve (reference Figure 1). Service kits for the Model CVE Check Valve include the following components:

- Clapper Rubber Facing and Clamping Ring Assembly (item 5)
- Clamping Ring Screws (item 6)
- Cover Gasket (item 10)

4" Model CVE Service Kit: PN 6501200R18

6" Model CVE Service Kit: PN 6501200R19

8" Model CVE Service Kit: PN 6501200R20

Model CVE Valve Dimensions (refer to Table C)

Figure 2

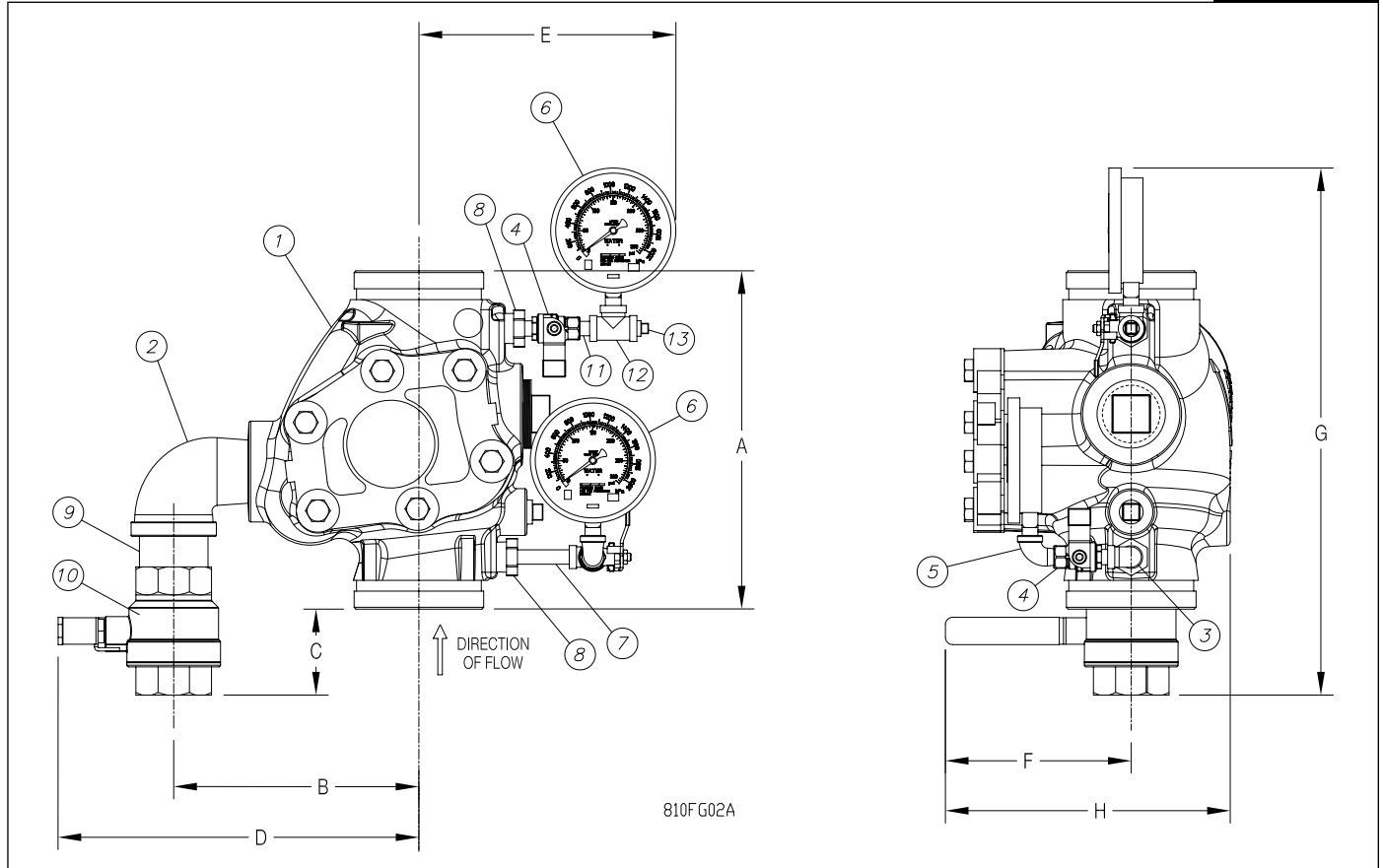

Model CVE Valve Dimensions (Refer to Fig. 2)

Table C

Valve Size	A	B	C	D	E	F	G	H
4" (100mm)	11-3/4" (298mm)	8-1/2" (216mm)	3" (76mm)	12-1/2" (318mm)	9" (229mm)	6-1/2" (165mm)	18-1/4" (464mm)	9-7/8" (251mm)
6" (150mm), 165mm	13-1/2" (343mm)	9" (229mm)		13" (330mm)	10-1/4" (260mm)		18-3/4" (476mm)	10-3/4" (273mm)
8" (200mm)	14-1/2" (368mm)	10-1/8" (257mm)		14-1/8" (359mm)	11" (279mm)		19-1/4" (489mm)	11-5/8" (295mm)

Model CVE Riser Check Valve Trim Parts List (Refer to Fig. 3)

Table D

Item No.	Part Name	Quantity	Part Number
1	Model CVE Check Valve	--	See Table E
2	Elbow, Street, 2", Mall Iron, Galv.	1	98174415
3	Elbow, 1/4", 90°, Galv.	1	98174404
4	Ball Valve, 1/4" NPTF x 1/4" NPTM	2	98840237
5	Elbow, 1/4", 90°, Street, Galv.	2	98174408
6	Gauge, Water Pressure, 0-300 PSI	2	98248001
7	Nipple, Galv, 1/4" x 2-1/2"	1	98543225
8	Bushing Reducer, Galv, 3/4" x 1/4"	2	98048025
9	Nipple, Steel, Galv., 2" x Close	1	98543238
10	Valve, Ball, 2" (Threaded)	1	98840136
11	Sho. Nipple, 1/4", Galv	1	98543227
12	Tee, 1/4", Galv	1	96606608
13	Plug, 1/4", Galv	1	98614403

Model CVE Valve Additional Part Numbers

Table E

Description	Factory Assembled Valve & Riser Trim	Valve Only	Riser Trim
Check Valve, Model CVE, 4" (GRV/GRV)	6506000040	6108040000	6506000044
Check Valve, Model CVE, 6" (GRV/GRV)	6506000041	6108060000	
Check Valve, Model CVE, 8" (GRV/GRV)	6506000042	6108080000	
Check Valve, Model CVE, 165mm (GRV/GRV)	6506000043	6108065000	

Installation

The Model CVE Check Valve/Riser Check Valve shall be installed in accordance with NFPA 13 "Standards for the Installation of Sprinkler Systems", as well as the requirements of the authorities having jurisdiction. When installed vertically, the direction of flow shall be up through the assembly. For horizontal installations, the hinge pin must be located to the top. Failure to follow installation instructions may void the warranty and/or listing of the valve. Verify compatibility of the Model CVE Valve materials with the water supply and the environment where the valve will be installed prior to installation.

Maintenance

The owner is responsible for maintaining the fire protection system in proper operating condition. Any system maintenance or testing that involves placing a system out of service may eliminate the fire protection that is provided by the fire protection system. Notify any required authorities having jurisdiction and implement appropriate precautions prior to proceeding.

The Model CVE Check Valve/Riser Check Valve shall periodically be given a thorough inspection and test. NFPA 25, "Inspection, Testing and Maintenance of Water Based Fire Protection Systems," provides minimum maintenance requirements. Replace any components found to be corroded, damaged, worn or non-operable. Increase the frequency of inspections when the valve is exposed to corrosive conditions or chemicals that could impact materials and/or operation of the assembly.

Guarantee

For the Reliable Automatic Sprinkler Co., Inc. guarantee, terms, and conditions, visit www.reliablesprinkler.com.

Ordering Information

Specify:

Model CVE:

- Check Valve
- Riser Check Valve

Size:

- 4" (100mm)
- 6" (150mm)
- 165mm
- 8" (200mm)

(For Riser Check Valve only):

- Loose Trim
- Factory Assembled Valve