

Reliable®

Model G Riser Check Valve

1-1/2", 2", 2-1/2", 3", 4", 6", 8", & 10" Sizes

cULus Listed, FM Approved

Features

- Grooved end connections.
- Compact, lightweight design.
- Non-slamming, spring loaded clapper to minimize water hammer.
- Approved for horizontal and vertical installation.
- Stream-lined body design provides very low friction loss.
- Gage ports provided both sides for universal application.

Product Description

Reliable Model G Riser Check Valves are intended for installation as wet pipe fire protection system risers. When used with a water flow detector to provide an electric alarm, the Model G Riser Check Valve is a cost effective alternative in installations not requiring a mechanical alarm.

Grooved end connections provide fast and easy installation using listed or approved mechanical grooved couplings. Rigid style grooved couplings can be used for positive clamping to resist flexural and torsional loads where required.

Model G Riser Check Valves are factory tapped for 3/4", 1-1/4", or 2" NPT drain depending on size. Factory tapped outlets (1/4" NPT upstream and 1/2" NPT) downstream are provided on each side of the valve to facilitate universal positioning (refer to Figure 2).



Technical Data

Table A

Valve Size	Pressure Rating	Face-to-Face Dimension	Eq. Length C = 120	Eq. Length C = 100	Cv Factor	Valve Shipping Weight	Trim Shipping Weight
1-1/2" (40 mm)	300 psi (20.7 bar)	6-1/4" (160 mm)	6.7' (2.0 m)	4.8' (1.5 m)	36	5 lbs (2.3 kg)	4 lbs. (1.8 kg)
2" (50 mm)		6-1/2" (165 mm)	9.6' (2.9 m)	6.8' (2.1 m)	67	6 lbs (2.7 kg)	
2-1/2" (65 mm)	250 psi (17.3 bar)	7-1/8" (180 mm)	6.0' (1.8m)	4.3' (1.3m)	212	9 lbs (4.1 kg)	6 lbs. (2.7 kg)
76 mm		7-1/8" (180 mm)	6.0' (1.8m)	4.3' (1.3m)	212	9 lbs. (4.1 kg)	
3" (80 mm)		7-5/8" (195 mm)	5.3' (1.6m)	3.8' (1.2m)	376	11 lbs. (5.0 kg)	
4" (100 mm)		8-7/16" (215 mm)	7.1' (2.2m)	5.0' (1.5m)	656	17 lbs. (7.7 kg)	9.25 lbs. (4.2 kg)
6" (150 mm)		10-1/4" (260 mm)	13.7' (4.2m)	9.8' (3.0m)	1395	38 lbs. (17.2 kg)	
165 mm		10-1/4" (260 mm)	13.7' (4.2m)	9.8' (3.0m)	1395	38 lbs. (17.2 kg)	
8" (200 mm)	12-1/2" (320 mm)	15.9' (4.8m)	11.3' (3.4m)	2818	63 lbs. (28.6 kg)		
10" (250 mm)	300 psi (20.7 bar)	14-1/2" (370 mm)	28.8' (8.8m)	20.6' (6.3m)	3928	102 lbs. (46.3 kg)	

Model G Riser Check Valve Components (refer to Table B)

Figure 1

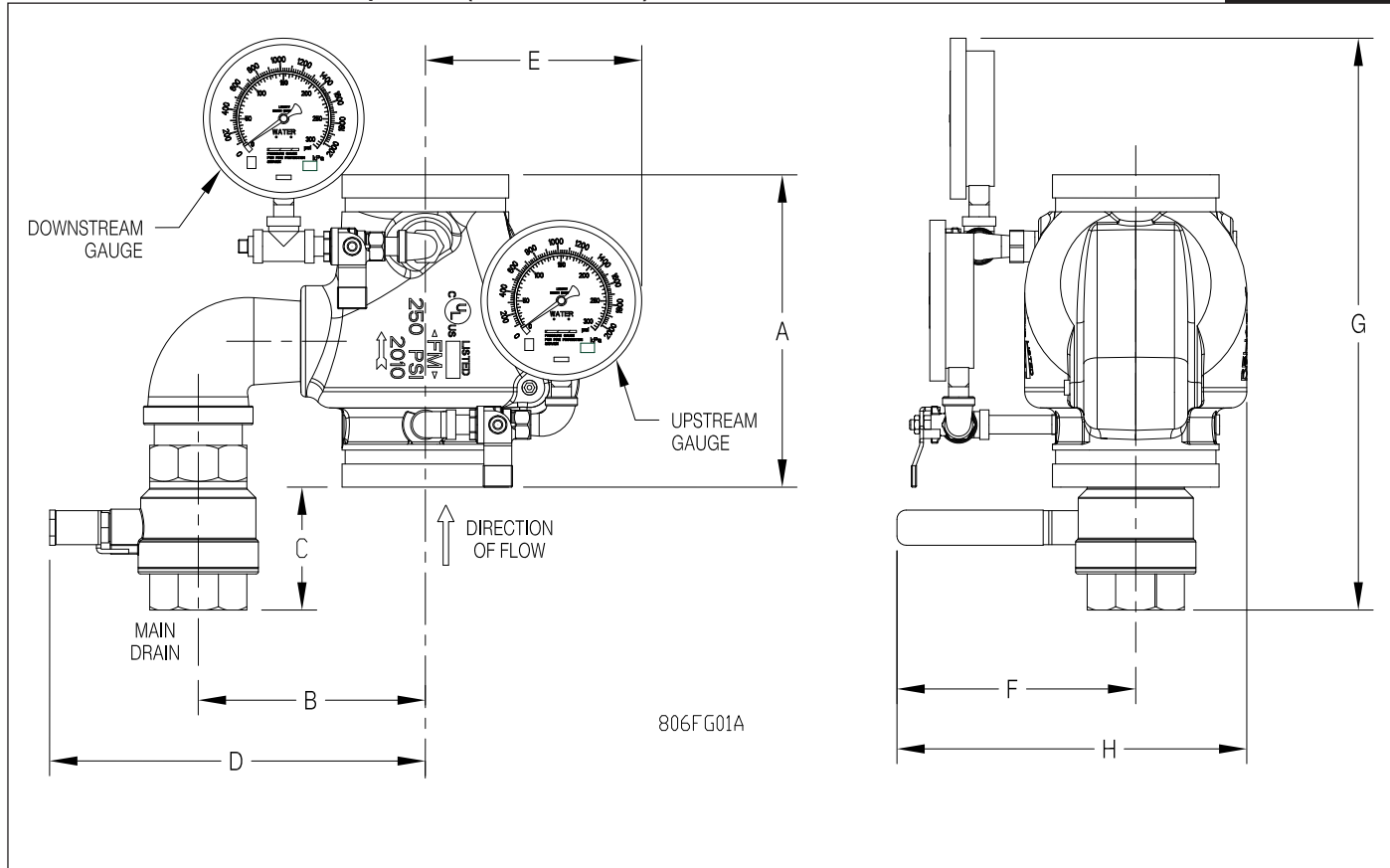

Model G Riser Check Valve Dimensions (refer to Fig. 1)

Table B

Valve Size	Dimensions							
	A	B	C	D	E	F	G	H
1-1/2" (40 mm)	6-1/4" (160mm)	3-1/2" (90mm)	3/8" (9.5mm)	4-15/16" (125mm)	5-3/4" (146mm)	3-5/16" (84mm)	10-5/8" (270mm)	4-7/8" (124mm)
2" (50 mm)	6-1/2" (165mm)	3-3/4" (95mm)	3/8" (9.5mm)	5-3/16" (132mm)	5-3/4" (146mm)	3-5/16" (85mm)	10-7/8" (276mm)	5-3/16" (132mm)
2-1/2" (65 mm)	7-1/8" (180mm)	4-11/16" (120mm)	1-15/16" (49.2mm)	5-3/16" (132mm)	5-3/4" (146mm)	5-1/2" (140mm)	13-1/8" (333mm)	7-3/4" (197mm)
76 mm	7-1/8" (180mm)	4-11/16" (120mm)	1-15/16" (49.2mm)	5-3/16" (132mm)	5-3/4" (146mm)	5-1/2" (140mm)	13-1/8" (333mm)	7-3/4" (197mm)
3" (80 mm)	7-5/8" (195mm)	4-15/16" (125mm)	1-15/16" (49.2mm)	7-11/16" (195mm)	5-3/4" (146mm)	5-1/2" (140mm)	13-1/8" (333mm)	8-1/8" (265mm)
4" (100 mm)	8-7/16" (215 mm)	6-1/8" (156mm)	3-5/16" (84.1mm)	10-1/8" (257mm)	5-3/4" (145mm)	6-7/16" (165mm)	15-1/2" (395mm)	9-7/16" (240mm)
6" (150 mm)	10-1/4" (260 mm)	7" (178mm)	3-5/16" (84.1mm)	11" (280mm)	5-3/4" (146mm)	6-7/16" (165mm)	15-1/2" (395mm)	10-7/16" (265mm)
165 mm	10-1/4" (260 mm)	7" (178mm)	3-5/16" (84.1mm)	11" (280mm)	5-3/4" (146mm)	6-7/16" (165mm)	15-1/2" (395mm)	10-7/16" (265mm)
8" (200 mm)	12-1/2" (320 mm)	8-1/8" (205mm)	3-5/16" (84.1mm)	12-1/8" (308mm)	5-3/4" (145mm)	6-7/16" (165mm)	17-3/4" (450mm)	11-7/16" (290mm)
10" (250mm)	14-1/2" (368mm)	9-1/8" (232mm)	3-5/16" (84.1mm)	13-1/8" (333mm)	5-3/4" (145mm)	6-7/16" (165mm)	19-3/4" (502mm)	12-7/16" (316mm)

Figure Components (refer to Table C)

Figure 2

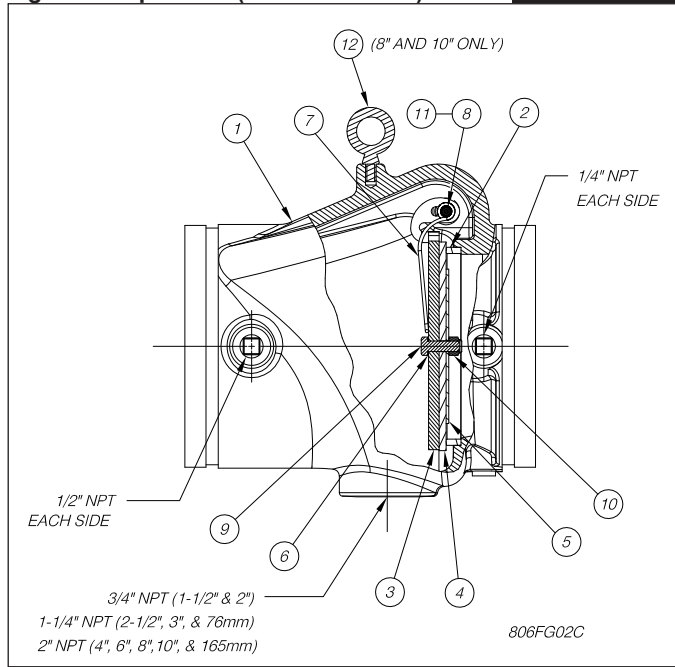

Figure Components (refer to Figure 2)

Table C

Item No.	Part Name	Material
1	Valve Body	Gray Iron, ASTM-A48 Class 30A
2	Seat	Bronze C83600 or C93200, ASTM-B505
3	Clapper	Stainless Steel 304, ASTM-A240
4	Facing Seal *	EPDM Rubber
5	Clamping Ring	Stainless Steel 304, ASTM-A240
6	Gasket *	EPDM Rubber
7	Spring	Stainless Steel 302, ASTM-A313
8	Hinge Pin	Stainless Steel 303, ASTM-A582
9	Bolt	Stainless Steel 304, ASTM-F593
10	Locknut *	Stainless Steel 303, ASTM-F594
11	Plug, 1/8" NPT	Steel
12	Shoulder Eye	Steel

* Part of Replacement Seal Kit

Replacement Seal Kits

Table D

	Part Number									
	1-1/2" (40mm)	2" (50mm)	2-1/2" (65mm)	76mm	3" (80mm)	4" (100mm)	6" (150mm)	165mm	8" (200mm)	10" (250mm)
Replacement Seal Kit	6888040015	6888040020	6888040025	6888040025	6888040030	6888040040	6888040060	6888040060	6888040080	6888040090
Body Seat Sub Assembly	9100520A	9100520B	91005202	91005201	91005203	91005204	91005206	91005205	91005218	91005210

Installation

The Model G Riser Check Valve shall be installed in accordance with NFPA 13, "Standard for the Installation of Sprinkler Systems," as well as the requirements of any authorities having jurisdiction. When installed vertically, the direction of flow shall be up through the assembly. For horizontal installations, the hinge pin must be located to the top. Failure to follow installation instructions may void the warranty and/or listing of the valve. Verify compatibility of the Model G Riser Check Valve materials with the water supply and the environment where the valve will be installed prior to installation.

Maintenance

The owner is responsible for maintaining the fire protection system in proper operating condition. Any system maintenance or testing that involves placing a system out of service may eliminate the fire protection that is provided by the fire protection system. Notify any required authorities having jurisdiction and implement appropriate precautions prior to proceeding.

The Reliable Model G Riser Check Valve shall periodically be given a thorough inspection and test. NFPA 25, "Inspection, Testing and Maintenance of Water Based Fire Protection Systems," provides minimum maintenance requirements. Replace any components found to be corroded, damaged, worn or non-operable. Increase the frequency of inspections when the valve is exposed to corrosive conditions or chemicals that could impact materials and/or operation of the assembly.

Guarantee

For Reliable Automatic Sprinkler, Co., Inc. guarantee, terms, and conditions, visit www.reliablesprinkler.com.

Ordering Information

Specify:

1. Reliable Model G Riser Check Valve
2. Size
3. Trim [PN 6506000015, 1-1/2" & 2" valves] [PN 6506000030, 2-1/2" & 3" valves] [PN 6506000020, 4", 6", 8", & 10" valves]