

# Reliable®

## Model DDX Non-Interlock Preaction Systems 2" (50 mm), 2½" (65 mm), 3" (80 mm), 76 mm, 4" (100 mm), 6" (150 mm), 165 mm & 8" (200 mm)

Bulletin 756 January 2025

### Technical Specifications and Instructions for Installation, Operation, and Maintenance

- Available with 175 psi (12.1 bar) or 300 psi (20.7 bar) Rated Solenoid Valve
- Pneumatic Actuator Utilizing 12 psi to 28 psi (0.8 to 1.9 bar) Supervising Pressure
- Externally Resettable Clapper
- One Main Drain



Image subject to change.

## General

The Reliable Model DDX Non-Interlock system operates as either an electric release single-interlock preaction system or a low-pressure dry pipe system, depending on what type of event occurs: detection system actuation or loss of system pneumatic pressure, respectively.

At the heart of the Reliable Non-Interlock Preaction System is the Model DDX Deluge Valve. This deluge valve is a hydraulically operated, straight-through-design, differential latching clapper-type (see Fig. 1). System maintenance is simplified since the deluge valve can be reset externally without removing the cover plate. This feature provides a significant system-restoration time advantage. The Model DDX Deluge Valve has an intermediate chamber and thereby does not require an in-line air check valve. Subsequently, the deluge valve only requires a single drain connection.

The trim sets for the Non-Interlock preaction systems provide all of the necessary equipment for connections to the Model DDX Deluge Valve pushrod chamber inlet and outlet ports, a 1¼" (30 mm) main drain on 2" (50 mm), 2½" (65 mm), 76 mm and 3" (80 mm) valve sizes or a 2" (50 mm) main drain on 4" (100 mm), 165 mm, 6" (150 mm) and 8" (200 mm) valve sizes, alarm devices, air supply, and required pressure gauges. The trim sets are available in individual (loose) parts, in time-saving, segmented assembled kit forms or fully assembled to the Model DDX Deluge Valve (with or without a control valve).

### Operation as Single Interlock Preaction:

The normally closed solenoid valve retains water pressure in the pushrod chamber of the Model DDX Deluge valve to maintain it closed. When the electrical detection system senses the presence of fire, the releasing control panel energizes (opens) the solenoid valve. Opening the solenoid valve relieves the pushrod chamber water pressure, thus operating the deluge valve and allowing water to flow into the sprinkler system. The flow of water into the sprinkler system piping essentially converts the dry system into a wet system. In the event that the fire subsequently produces enough heat to operate a fire sprinkler, water will flow from that sprinkler.

### Operation as Dry Pipe System:

The LP dry pilot actuator is held closed using the pressurized air or nitrogen in the system. The actuator retains water pressure in the pushrod chamber of the Model DDX Deluge valve to maintain it closed. When a fire sprinkler opens due to fire, loss of air or nitrogen pressure on the air side of the dry pilot actuator allows it to open. Opening the actuator relieves the pushrod chamber water pressure, thus operating the deluge valve and allowing water to flow into the system and discharge from the open sprinkler(s).

### Listings & Approvals:

When used with Reliable trim sets, Reliable 2" (50mm), 2-1/2" (65mm), 76mm, 3" (80mm), 4" (100mm), 6" (150mm), 165mm, and 8" (200mm) Model DDX Non-Interlock systems are Underwriters Laboratories listed in the Special Water Control Valve - Deluge Type (VKYL) category

## System Operation

Once the clapper has opened, the lever acts as a latch, preventing the clapper from returning to the closed position. Water from the supply flows through the Deluge Valve into the system piping. Water also flows through the alarm outlet to the alarm devices.

Resetting the clapper of the Model DDX Deluge Valve is accomplished using the convenient external reset knob on the rear of the valve. The external reset feature of the Model DDX Deluge Valve provides a means for simple, economical system testing, which is one essential facet of a good maintenance program. The external reset feature does not, however, eliminate another important facet of good maintenance, namely, periodic cleaning and inspection of the internal valve parts.

A valve body drain is provided in the event that water builds up due to condensate from the air supply system or water left inside from system testing. After closing the main supply valve, the condensate drain can be opened slightly until the water inside the valve body and the main pipe column has drained. See the section titled "Draining Excess/Condensate Water From System" in this bulletin for the detailed procedure.

The Model B Manual Emergency Station is also included in all Reliable Non-Interlock Preaction System trim sets. It consists of an aluminum nameplate mechanically attached to a ball valve. The valve handle in its OFF position is guarded against accidental turning to the ON position (and system discharge) by a nylon cable tie provided with each trim kit. The cable tie is inserted after the system has been restored for operation. The nylon cable tie is designed to allow, in case of an emergency, forceful turning of the valve handle to the ON position. As an alternative to the Model B Hydraulic Manual Emergency Station, the Model A Hydraulic Manual Emergency Pull Box (see Reliable Bulletin 506) is also available and can be provided as an option.

Whenever ambient temperature conditions are high, the water temperature in the Model DDX Deluge Valve pushrod chamber could possibly increase, thereby increasing the pressure in the chamber to values exceeding the rated pressure of the system. In an indoor installation where standard room temperatures are exceeded, a pressure relief kit may be needed. Pressure relief kit, P/N 6503050001, can be installed into the pushrod chamber's releasing line to limit the pressure to 250 psi (17.2 bar).

Reliable Model DDX Deluge Valve with associated Non-Interlock Preaction Trims sizes 2" (50 mm), 2½" (65 mm), 76 mm, 3" (80 mm), 4" (100 mm), 165 mm, 6" (150 mm) and 8" (200 mm) are rated for use at a minimum water supply pressure of 50 psi (3.4 bar); and a maximum water supply pressure of 250 psi (17.2 bar) for 2" (50mm), 2½" (65mm), 76mm, 3" (80mm) and 8" (200mm) valve sizes and 300 psi (20.7 bar) for 4" (100mm), 165mm and 6" (150mm) valve sizes. Water supplied to the inlet of the valve and to the pushrod chamber must be maintained between 40°F (4°C) and 140°F (60°C).

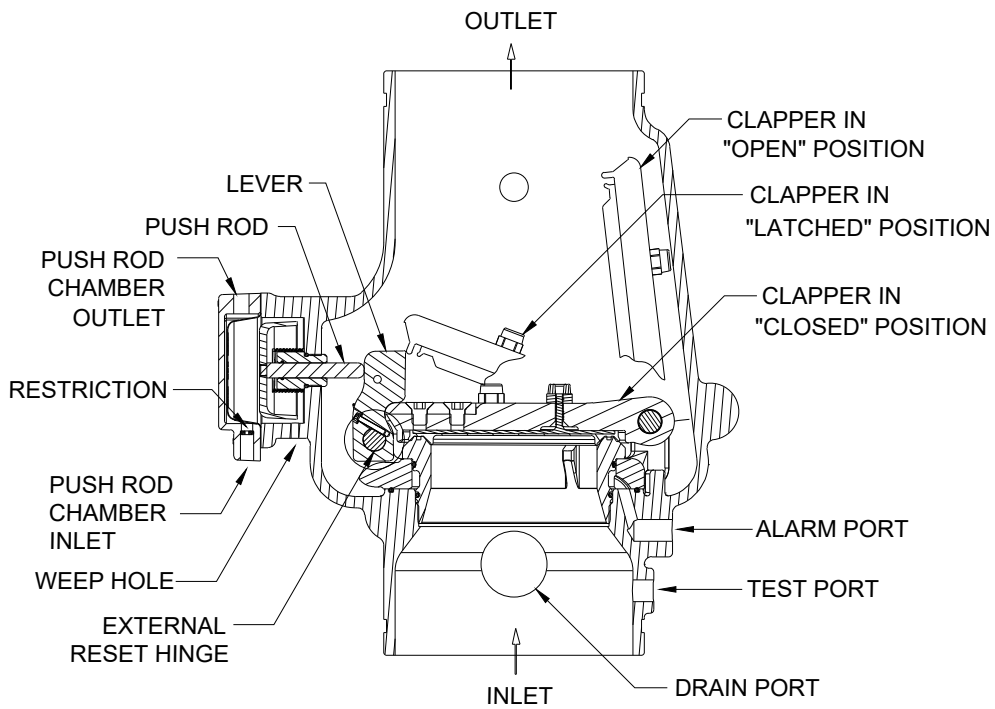

MODEL DDX VALVE: SECTION VIEW

1C\_COMMDDX\_1

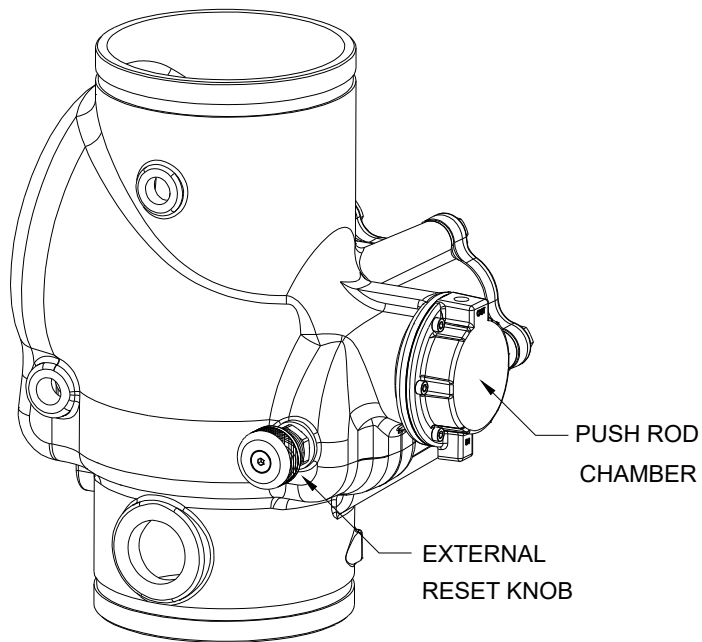

MODEL DDX VALVE: REAR VIEW

TO RESET: PUSH INWARD AND ROTATE KNOB CLOCKWISE (AS VIEWED FROM REAR)  
 TO RESET CLAPPER. NOTE: PUSH ROD CHAMBER MUST BE VENTED TO DRAIN.

Fig. 1

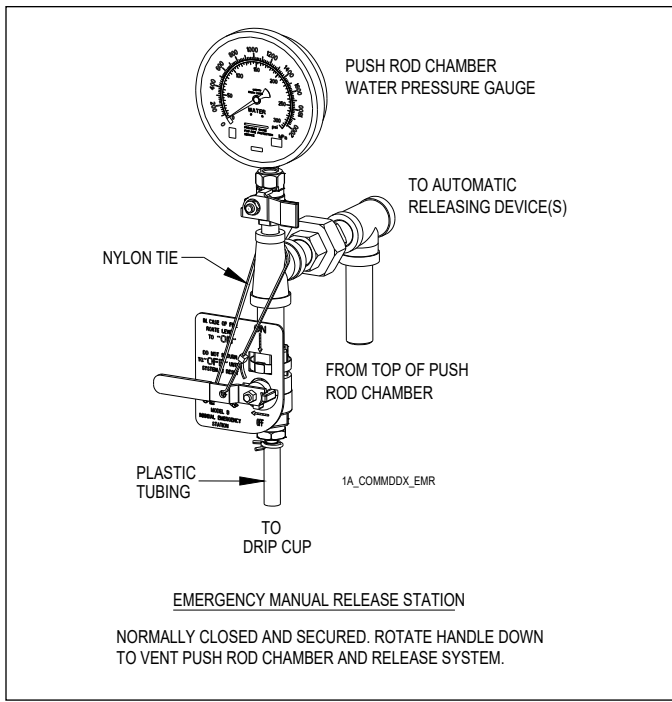

## Pressurizing Line Connection

The water supply for the pushrod chamber must be provided from a dedicated connection to the water supply piping. Pressurizing lines for multiple Model DDX Deluge Valve pushrod chambers must never be manifolded together. Each Model DDX Deluge Valve must have its own pushrod chamber pressurizing line connection.

This connection must be made on the supply side of the water supply control valve. This can be accomplished by:

- Using a tapped connection directly below or next to the main water supply control valve using a welded outlet or the appropriate mechanical fittings. A grooved-end outlet coupling is one way to achieve this; or
- Using a water supply control valve that has an available threaded (NPT) supply-side tap design to allow for a direct water supply connection to the Model DDX Deluge Valve pushrod chamber.

**Caution:** The Reliable DDX valve is designed with an inlet restriction built into the pushrod chamber. It is important not to introduce additional restrictions into the direct water supply connection or the discharge from the pushrod chamber by installing additional valves or improperly installing the copper lines used in the trim of the valve.

## Hydrostatic Testing of DDX Valves and DDX Systems

As required by NFPA 13, fire sprinkler systems with working pressures up to and including 150 psi are to be hydrostatically tested at a water pressure of 200 psi. Fire sprinkler systems with working pressures above 150 psi are required to be hydrostatically tested at 50 psi above the system working pressure. In addition to the hydrostatic tests described above, dry pipe and double interlock preaction systems require an additional low pressure air test.

In some cases, hydrostatic testing (in accordance with the NFPA 13 requirements noted above) will result in pressures that exceed the working pressure of the valve and trim kit for the two-hour test period. The valve and applicable trim kit have been tested, approved and listed under these conditions and as such, hydrostatic testing in accordance with NFPA 13 is acceptable. In addition, the clapper can remain in the closed position and the trim kit need not be isolated, as each has been designed to withstand hydrostatic testing as required by NFPA 13.

Hydrostatically testing the valve and trim to pressures higher than their rating is limited to the hydrostatic test as referenced by NFPA 13. It does not address the occurrence(s) of a “water hammer” effect, which can damage the valve. A “water hammer” in the water supply piping of the valve can create pressures in excess of the rated pressure and should be avoided by all necessary means. This condition may be created from improper fire pump settings, underground construction work, or an improper venting of trapped air in the water supply piping.

## System Design Considerations

The automatic sprinklers, air compressor, releasing devices, electric releasing control equipment, fire detection devices, manual pull stations, and signaling devices which are utilized with the Non-Interlock Preaction System must be UL or ULC Listed. The solenoid valve must be operated and the system supervised by a listed releasing control panel.

The Deluge Valve, and all interconnecting piping must be located in a readily visible and accessible location and in an area that can be maintained at a minimum temperature of 40°F (4°C). **Note:** Heat tracing is not permitted.

Pendent sprinklers, other than dry pendants, used on preaction systems shall be installed on return bends per NFPA 13.

**IMPORTANT:** The unique ability of the non-interlock system to operate as both a single-interlock preaction system and a dry pipe system requires that the Model DDX be supplied with **NO LESS THAN 50 psi (3.5 bar)** of water pressure, and supervisory air pressure in strict accordance with Table A. Water supply pressure less than 50 psi (3.5 bar) or supervisory air pressure in excess of the value in Table A will result in non-operation of the valve in the dry pipe mode.

## System Air Pressure Requirements

The system trim includes gauges to read the pneumatic and water pressures of the Type PL Double Interlock Preaction System. Table A specifies the air or nitrogen pressure to be constantly applied to the system. A properly designed pneumatic supply system automatically regulates pressure, provides a safeguard against small pressure leaks in the sprinkler piping, and properly restricts the flow of makeup air or nitrogen from the source. See Reliable Bulletins 251 and 254 for complete information on air and nitrogen regulating equipment.

When the optional Reliable Model B1 Accelerator is used to expedite valve operation time, the pneumatic pressure must not be less than 15 psi (1.0 bar). Please reference Bulletin 323.

**Table A**

Water Pressure psi (bar)	Pneumatic Pressure to be Pumped into Sprinkler System psi (bar)	
	Not Less Than	Not More Than
50 (3.4)	12 (0.8)	14 (1.0)
75 (5.2)	13 (0.9)	15 (1.0)
100 (6.9)	15 (1.0)	17 (1.2)
125 (8.6)	16 (1.1)	18 (1.2)
150 (10.3)	17 (1.2)	19 (1.3)
175 (12.1)	18 (1.2)	20 (1.4)
200 (13.8)	19 (1.3)	21 (1.4)
225 (15.5)	21 (1.4)	23 (1.6)
250 (17.2)	22 (1.5)	24 (1.7)
275 (19.0)	23 (1.6)	25 (1.7)
300 (20.7)	24 (1.7)	26 (1.8)

### Notes:

- Supervisory air or nitrogen pressure should not exceed 30 psi (2.1 bar). Excess pressure may result in damage to the actuator.
- Fastest valve operation is achieved with supervisory air or nitrogen pressure indicated; however, pressure must never be less than the minimum specified in the table above.
- Air maintenance devices that maintain a constant pressure are recommended; however, if a tank-less compressor is used, the "compressor on" setting of the pressure switch must never be lower than the minimum pressure in the table above.

During system set-up, a higher pneumatic pressure may be required in order to properly set the Model LP Dry Pilot Line Actuator. If higher pressure is used, ensure the pneumatic pressure is adjusted to the correct value from the table when placing the system in service.

Whenever multiple systems are supplied by a common air or nitrogen source, each system must have its own pressure maintenance device for individual maintenance of pressure per the requirements of NFPA 13.

**DO NOT** use bleeder valves for testing of the low-pressure switch on the trim. Release of pneumatic pressure from the actuator trim will result in operation of the system.

## System Electrical Requirements

When Using the Electric Actuation Non-Interlock Preaction System, all releasing, alarm and detection devices in the Non-Interlock Preaction System may be supervised by the Potter PFC-4410-RC Releasing Control Panel. The panel should be set to use Program #6 for single zone detection or Program #7 for cross-zone detection (See Potter Instruction Manual #5403550).

The power supply, the standby emergency power supply, battery charger, and the rectifier circuitry are all contained within the Potter PFC-4410-RC Releasing Control Panel. The solenoid valve is operated and supervised by the Potter PFC-4410-RC Releasing Control Panel. Potter PFC-4410-RC Releasing Control Panel requires 120 VAC.

When using releasing control panels from other manufacturers, verify the the panel is compatible with the solenoid valves provided with the Model DDX Non-Interlock system.

### Standard Solenoid Valve Specifications:

Parker-Hannifin Model 73218BN4UNLVN0C111C2  
 Rated working pressure: 175 psi (12.1 bar)  
 Voltage: 24 VDC  
 Power: 10 Watts  
 Current: 0.41 Amps Holding  
 Enclosure Coil: NEMA 4X  
 Pipe Size: ½" NPT Female  
 Cv Factor: 4.0

### Alternate Solenoid Valve Specifications:

Parker-Hannifin Model 73212BN4TNLVN0C322C2  
 Rated working pressure: 300 psi (20.7 bar)  
 Voltage: 24 VDC  
 Power: 22 Watts  
 Current: 0.83 Amps Holding  
 Enclosure Coil: NEMA 4X  
 Pipe Size: ½" NPT Female  
 Cv Factor: 2.8

### Technical Data

Reliable Non-Interlock Preaction Systems, with associated trim, size 2" (50 mm), 2½" (65 mm), 76 mm, 3" (80 mm), 4" (100 mm), 165 mm, 6" (150 mm) & 8" (200 mm) are rated for use at minimum water supply pressure of 50 psi (3.4 bar) and maximum supply pressure of 250 psi (17.2 bar) for 2" (50mm), 2½" (65mm), 76mm, 3" (80mm) and 8" (200mm) valve sizes and 300 psi (20.7 bar) for 4" (100mm), 165mm and 6" (150mm) valve sizes. Water supplied to the inlet of the valve and to the pushrod chamber must be maintained between 40°F (4°C) and 140°F (60°C).

## Model DDX Deluge Valve Description

- Rated working pressure:  
Valve & System - 250 psi (17.2 bar) for 2" (50mm), 2½" (65mm), 76mm, 3" (80mm) and 8" (200mm) valve sizes and 300 psi (20.7 bar) for 4" (100mm), 165mm and 6" (150mm) valve sizes.
- Factory tested to a hydrostatic pressure of 500 psi (34.5 bar) for 2" (50mm), 2½" (65mm), 76mm, 3" (80mm) and 8" (200mm) valve sizes and 600 psi (41.4 bar) for 4" (100mm), 165mm and 6" (150mm) valve sizes. (Valve only)
- End and trim connections:
  - ANSI/AWWA C606 grooved inlet and outlet

Nominal Pipe Size	Outlet Diameter	Groove Diameter	Groove Width	Outlet Face to Groove
2" (50 mm)	2.375" (60mm)	2.250" (57mm)	11/32" (9.0mm)	5/8" (16mm)
2½" (65 mm)	2.875" (73mm)	2.720" (69mm)	11/32" (9.0mm)	5/8" (16mm)
76 mm	3.000" (76mm)	2.845" (72mm)	11/32" (9.0mm)	5/8" (16mm)
3" (80 mm)	3.500" (89mm)	3.344" (85mm)	11/32" (9.0mm)	5/8" (16mm)
4" (100 mm)	4.500" (114mm)	4.334" (110mm)	3/8" (9.5mm)	5/8" (16mm)
165 mm	6.500" (165mm)	6.330" (161mm)	3/8" (9.5mm)	5/8" (16mm)
6" (150 mm)	6.625" (168mm)	6.455" (164mm)	3/8" (9.5mm)	5/8" (16mm)
8" (200 mm)	8.625" (219mm)	8.441" (214mm)	7/16" (11mm)	3/4" (19mm)

- Threaded openings Per ANSI B 2.1
- Flange Dimensions

Flange Type	Nominal Pipe Size	Bolt Circle Diameter	Bolt Hole Diameter	Flange Outside Diameter	Flange Thickness	Number of Bolts
ASME B16.5 Class 150	4" (100mm)	7½" (191mm)	¾" (19mm)	9" (229mm)	15/16" (24mm)	8
ISO 7005-2 PN16	4" (100mm)	7½" (180mm)	¾" (19mm)	9" (229mm)	15/16" (24mm)	8
ASME B16.5 Class 150	6" (150mm)	9½" (241mm)	7/8" (22mm)	11" (279mm)	15/16" (24mm)	8
ISO 7005-2 PN16	6" (150mm)	9½" (240mm)	29/32" (23mm)	11" (279mm)	15/16" (24mm)	8
ASME B16.5 Class 150	8" (200mm)	11¾" (298mm)	7/8" (22mm)	13½" (343mm)	1" (25.4mm)	8
ISO 7005-2 PN16	8" (200mm)	11½" (295mm)	29/32" (23mm)	13½" (343mm)	1" (25.4mm)	12

- Valve Exterior's Color:

Valve Size	Color
2" (50 mm)	Black or Red
2½" (65 mm)	Black or Red
76 mm	Red
3" (80 mm)	Black or Red
4" (100 mm)	Black or Red
165 mm	Red
6" (150 mm)	Black or Red
8" (200 mm)	Black or Red

- Face to face dimensions:

Valve Size:	End Connection:	End to End:
2" (50mm), 2½" (65mm), 76mm & 3" (80mm)	Groove/ Groove	12½" (318mm)
4" (100mm)	Groove/ Groove	14" (356mm)
	Flange/ Groove	16" (406mm)
	Flange/ Flange	16" (406mm)
6" (150mm) & 165mm	Groove/ Groove	16" (406mm)
	Flange/ Groove	19" (483mm)
	Flange/ Flange	19" (483mm)
8" (200mm)	Groove/ Groove	19½" (492mm)
	Flange/ Flange	21¼" (540mm)

- Valve Shipping Weight:

Valve Size:	End Connection:	Weight:
2" (50mm), 2½" (65mm), 76mm & 3" (80mm)	Groove/ Groove	34 lbs (15 kg)
4" (100mm)	Groove/ Groove	64 lbs (29 kg)
	Flange/ Groove	79 lbs (36 kg)
	Flange/ Flange	92 lbs (42 kg)
6" (150mm) & 165mm	Groove/ Groove	95 lbs (43 kg)
	Flange/ Groove	122 lbs (56 kg)
	Flange/ Flange	138 lbs (69 kg)
8" (200mm)	Groove/ Groove	148 lbs (67 kg)
	Flange/ Flange	197 lbs (90 kg)

- Trim Shipping Weight:

Trim Configuration	2" (50 mm), 2½" (65 mm), 3" (80 mm) & 76 mm	4" (100 mm), 6" (150 mm), 8" (200 mm) & 165 mm
Wet Pilot Non-Interlock	32 lbs (15 kg)	38 lbs (17 kg)
Dry Pilot Non-Interlock	45 lbs (20 kg)	52 lbs (24 kg)
Electric Actuation Non-Interlock	35 lbs (16 kg)	40 lbs (18 kg)

- Friction loss (Expressed in equivalent length of Schedule 40 pipe, based on Hazen & Williams formula:

Valve Size:	Equivalent Length:		Cv
	C = 120	C = 100	
2" (50mm)	4.4 ft (1,3 m)	3.1 ft (1,0 m)	101
2½" (65mm)	6.0 ft (1,8 m)	4.3 ft (1,3 m)	236
76mm	7.7 ft (2,3 m)	5.5 ft (1,7 m)	241
3" (80mm)	12.6 ft (3,8 m)	9.0 ft (2,7 m)	254
4" (100mm)	14 ft (4,3 m)	10 ft (3,0 m)	469
165mm	29.4 ft (9,0 m)	20.9 ft (6,4 m)	886
6" (150mm)	29.4 ft (9,0 m)	20.9 ft (6,4 m)	886
8" (200mm)	53.5 ft (16,3 m)	38.1 ft (11,6 m)	1516

- Installation position: Vertical ONLY.

## Trim Descriptions

The Non-Interlock Preaction Trim for the Reliable Model DDX Deluge Valve is arranged for rapid, easy, and compact attachment, and serve as connection points to Reliable Model C Mechanical Alarms and other devices.

Trim can be ordered as individual parts, in time-saving segmentally assembled kit forms, or fully assembled to the Model DDX Deluge Valve (with or without a control valve).

The Model B Hydraulic Manual Emergency Station is a standard item of all deluge valve trim sets. It consists of an aluminum nameplate mechanically attached to a ball valve. The valve handle in its OFF position is guarded against accidental turning to the ON position (and system discharge) by a nylon cable tie provided with each trim kit. The cable tie is inserted, after the system has been restored for operation. The nylon cable tie is designed to allow, in case of an emergency, forceful turning of the valve handle to the ON position. As an alternative to the Model B Hydraulic Manual Emergency Station, the Model A Hydraulic Manual Emergency Pull Box (see Bulletin 506) is also available and can be provided as an option.

## Maintenance

Reliable Non-Interlock Preaction Systems and associated equipment shall periodically be given a thorough inspection and test. NFPA 25, Inspection, Testing and Maintenance of Water Based Fire Protection Systems, provides minimum maintenance requirements. System components shall be tested, operated, cleaned, and inspected at least annually, and parts replaced as required.

## Resetting Model DDX Non-Interlock Preaction Systems

1. Close the valve controlling water supply to the Deluge Valve and close the air or nitrogen supply to the sprinkler system. This will allow the Model LP Actuator to open.
2. Close the pushrod chamber supply valve.
3. Open main drain valve and drain the system.
4. Open all drain valves and vents at low points throughout the system, closing them when flow of water has stopped. Open the Model B Manual Emergency Station to relieve pressure in the pushrod chamber of the Deluge Valve.
5. With the alarm line valve open, push in the plunger of ball drip valve, forcing the ball from its seat, and drain the alarm line.
6. With the Model B Manual Emergency Station open, push in and rotate the Deluge Valve's external reset knob counterclockwise (when facing the valve), until you hear a distinct noise indicating that the clapper has reset. **Note:** The reset knob can be rotated only while pressure in the pushrod chamber is vented to atmospheric conditions (0 psig).

7. Inspect and replace any portion of the detection system and/or sprinkler system subjected to fire conditions. If the detection/release panel was reset, activate the detection system to energize the solenoid valve open.
8. Close the alarm line valve.
9. Open the pushrod chamber supply valve and allow water to fill the pushrod chamber. Close the Model B Manual Emergency Station when a solid stream of water passes through the drain tube, directing water through the Model LP Actuator and the solenoid release valve.
10. Bleed all air from the actuation piping in the following order:
  - A. Model LP Actuator--When a solid stream of water is seen passing through the drain tube, apply pneumatic pressure to the system and allow pressure to close the pneumatic actuator. Adjust the pneumatic pressure to the value in Table A based on water supply pressure. SET PNEUMATIC SUPPLY TO AUTOMATIC OPERATION.
  - B. Solenoid Valve--When a solid stream of water is seen passing through the drain tube, reset the release panel to close the electric solenoid valve.

**Note:** To build supervisory air pressure in the sprinkler system, it may be necessary to temporarily close the main drain valve. Partially open the main drain valve after pneumatic pressure is established on the system.

11. Open the alarm line valve. Verify the main drain valve is open. Open slightly the main valve controlling water supply to the Model DDX Deluge Valve, closing the main drain valve when water flows. Observe if water leaks through the ball drip valve into the drip cup. If no leak occurs, the Deluge Valve clapper is sealed. Open slowly and verify the main valve controlling water supply is fully opened and properly monitored.
12. Verify that the pushrod chamber supply valve and alarm line valve are open. **The pushrod chamber supply valve must remain open when the Deluge Valve has been reset, to maintain water pressure in the pushrod chamber.**
13. Verify that the Model B Manual Emergency Station is secured in the OFF position with the appropriate nylon tie.

## Inspection and Testing

1. **Water supply** — Confirm that valves controlling water supply to the Deluge Valve are opened fully and properly monitored.
2. **Alarm line** — Confirm that the alarm line valve is open and remains in this position.
3. **Other trim valves** — Confirm that the pushrod chamber supply valve and all pressure gauge valves are open. The main drain valve, condensate drain valve, and alarm test valve should be closed.
4. **Ball drip valve** — Push in on the plunger to be sure ball check is off its seat. If no water appears, the Deluge Valve water seat is tight. Inspect the bleed hole on the underside of the pushrod chamber for leakage.
5. **Pneumatic Pressure** -- Confirm that the system air or nitrogen pressure is in strict compliance with the value in Table A based upon the incoming water pressure.  
**Note:** Exceeding the “Not More Than” pressure values in Table A will result in non-operation of the valve in the single-interlock preaction mode.
6. **Releasing device** — Check outlet of the releasing device (i.e., the dry pilot line actuator, solenoid valve, or the hydraulic manual emergency station) for leakage. Also verify that tubing drain lines from releasing devices are not pinched or crushed which could prevent proper releasing of the Deluge Valve.
7. **Testing alarms** — Open the alarm test valve permitting water from the supply to flow to the electric sprinkler alarm switch and to the mechanical sprinkler alarm (water motor). After testing, close this valve securely. Push in on the plunger of ball drip valve until all water has drained from the alarm line.
8. **Operation test** — Open the Model B Manual Emergency Station, or alternatively, operate the detection system..  
**NOTE:** AN OPERATIONAL TEST WILL CAUSE THE DELUGE VALVE TO OPEN AND FLOW WATER INTO THE SPRINKLER SYSTEM.
9. Secure the Model B Manual Emergency Station in the OFF position with nylon tie after Deluge Valve is reset.

## Testing Detection System Without Operating Deluge Valve

1. Close the valve controlling water supply to Deluge Valve and open the main drain.
2. Verify that the pushrod chamber supply valve is open.
3. Operate the wet pilot line, dry pilot line, or electrical detection system.
4. Operation of the detection system must result in a sudden drop of water pressure in the pushrod chamber.
5. Reset detection system — reverse operations performed in step three above and then proceed according to the directions listed in the “Resetting Model DDX Deluge Valve Non-Interlock Preaction Systems” section of this bulletin for resetting the Deluge Valve.

## Draining Excess/Condensate Water From System

1. Close the main valve controlling water supply to Deluge Valve. Open the main drain valve.
2. Slightly open the condensate drain valve until all water has drained. Close the condensate drain valve. **Note:** Leaving the condensate drain valve open for an extended period of time may allow excess air or nitrogen to bleed off resulting in an undesirable low pressure supervisory signal.
3. Allow the air or nitrogen pressure to return to the normal level.
4. Slightly open the main valve controlling water supply to the system.
5. Slowly close the main drain valve.
6. Fully open the main valve controlling water supply to the system, and verify that it is properly monitored.

## Maintenance Procedures - Model DDX Deluge Valve

1. **Mechanical sprinkler alarm not operating:** This is most likely caused by a clogged screen in the strainer of the water motor. Proceed as follows: Remove plug from the strainer. Remove and clean the screen. Replace the screen and the plug, and then tighten securely (Ref. Bulletin 613).
2. **Water leaking from Ball Drip.** This can be caused by either a water column on top of the clapper or a supply water leakage.
  - a. **Leakage due to water column.** This condition is caused by leakage past the clapper seal assembly. Be sure the clapper seal and seat are free of any type of debris or damage. If necessary, follow steps below to replace the seal assembly and/or seat.
  - b. **Supply water leakage.** This condition is caused by leakage past the lower seat O-ring. Follow steps below for inspection and/or replacement of lower seat O-ring.
3. **Air or nitrogen leaking from Ball Drip.** This condition is caused by leakage past either the clapper seal assembly or the upper seat O-ring.
  - a. **Clapper seal leak.** Be sure the clapper seal and seat are free of any type of debris or damage. If necessary, follow steps below to replace the seal assembly and/or seat.
  - b. **Upper seat O-ring.** Follow steps below for inspection and/or replacement of upper seat O-ring.



## Repair Procedures - Model DDX Deluge Valve

The following section provides instructions to correct both conditions:

1. Disable detection system and supervisory pneumatic supply to system.
2. Shut down the valve controlling the water supply to the Deluge Valve and open the main drain valve. Open the condensate drain valve. Close the pushrod chamber supply valve and open the Model B Manual Emergency Station.
3. Remove the Deluge Valve front (handhold) cover and inspect the seat, clapper, and seal assembly for damage. If inspection indicates damage to the seal assembly only, replace as follows:
4. Remove the bumpstop nuts and remove the seal assembly. Install a new seal assembly and thread the bumpstop nuts onto the threaded studs of the seal assembly. Tighten finger tight plus  $\frac{1}{4}$  to  $\frac{1}{2}$  turn.
5. If inspection indicates damage to the clapper, proceed to step 6.
6. At the rear of the valve, disconnect the condensate drain trim section starting with the elbow connector. Then remove the  $\frac{1}{4}$ " globe valve, followed by the  $\frac{3}{4}$ "x $\frac{1}{4}$ " reducing bushing. Remove the retaining rings from the clapper hinge pin, push the hinge through the condensate drain opening and remove the clapper subassembly. Install a new clapper subassembly in the reverse order making sure the clapper spacers are in their proper position.
7. If the seat is damaged, or it is suspected that the leakage is through the seat O-rings, proceed to step 8.
8. Using Reliable P/N 6881603000 Seat Wrench for 2" (50mm), 2½" (65mm), 76mm and 3" (80mm) valve sizes, Reliable P/N 6881604000 for 4" (100mm) valve size, Reliable P/N 6881606000 for the 6" (150mm) and 165mm valve sizes or Reliable P/N 6881608000 Seat Wrench for 8" (200mm) valve size, remove the seat by unscrewing. This will loosen the seat-clapper-mounting ring subassembly. Reach into the valve and grasp the seat and remove it from the valve. Then remove the clapper-mounting ring subassembly from the valve. Visually examine all components of the seat-clapper-mounting ring subassembly replacing any component that appears damaged. New O-rings should always be used for reassembly.
9. Reassembly: clean the bore of the valve body. Lubricate the bore with O-ring grease. Lubricate and install the O-rings onto the seat. Lubricate and install the mounting ring O-ring into the body (8" (200mm) valve size only). Insert the clapper-mounting ring subassembly into the handhold opening of the Deluge Valve using caution to not damage or dislodge the mounting ring O-ring (8" (200mm) valve size only). Align the mounting ring so that the Lever is near the pushrod and the mounting ring "ears" are between the tabs of the valve body. Insert the seat into the valve body and through the clapper-mounting ring subassembly. Start to tread the seat into the body by hand, then tighten the seat with the seat

wrench until it bottoms out on the mounting ring. Verify that the seat-clapper-mounting ring subassembly is in the fully down position between the tabs of the body, and check to see that the lever lines up with the pushrod. Reassemble the handhold cover and set up the Model DDX Deluge Valve as per the section "Resetting Model DDX Deluge Valve Non-Interlock Preaction Systems".

## Pushrod Chamber Maintenance - Model DDX Deluge Valve

A small bleed hole is located on the underside of the pushrod chamber. If there is air or water leakage coming out of the bleed hole:

- a) Disable detection system and supervisory pneumatic supply to system.
- b) Shut down the valve controlling water supply to the Deluge Valve. Relieve the inlet pressure by opening the main drain valve. Close the valve that supplies water to the pushrod chamber, and open the Model B Manual Emergency Station.
- c) Remove the trim at the unions nearest to the pushrod chamber cover.
- d) Take the pushrod chamber cover off by removing the six retaining screws.

### CONDITION ONE (Water coming out of the bleed hole):

Water coming out of the bleed hole is caused by a leaking diaphragm. Visually inspect the pushrod chamber cover and piston to determine what could have damaged the diaphragm and then correct. Install a new diaphragm.

**NOTE:** The diaphragm has two different surfaces; it is not bi-directional. It will fail if installed backwards! Roll the diaphragm so that the smooth surface (the pressure side) conforms to the inside of the pushrod chamber cover and the fabric side engages the pushrod, and reassemble the six retaining screws with an installation torque of 15 foot-pounds in a star pattern. Set up the Model DDX Deluge Valve as per the section "Resetting Model DDX Deluge Valve Non-Interlock Preaction Systems".

### CONDITION TWO (System Air coming out of the bleed hole):

System air coming out of the bleed hole is caused by a defective O-ring assembled to the pushrod guide. Remove the piston-pushrod subassembly, pushrod spring, and pushrod guide. Verify by hand turning, that the pushrod cannot be unscrewed from the piston. Replace all O-rings and the pushrod guide. The correct installation torque for the pushrod guide is 35 inch-pounds. **CAUTION:** Do not over tighten the pushrod guide. Reassemble the components that were initially removed. Re-install the diaphragm if it appears to be in good shape, otherwise, replace it also. **NOTE:** The diaphragm has two different surfaces; it is not bi-directional. It will fail if installed backwards! Roll the diaphragm so that the smooth surface (the pressure side) conforms to the inside of the pushrod chamber cover and the fabric side engages the pushrod, and reassemble the six retaining screws with an installation torque of 15 foot-pounds in a star pattern. Set up the Model DDX Deluge Valve as per the section "Resetting Model DDX Deluge Valve Non-Interlock Preaction Systems".



### MODEL DDX HYDRAULIC FRICTION LOSS GRAPH

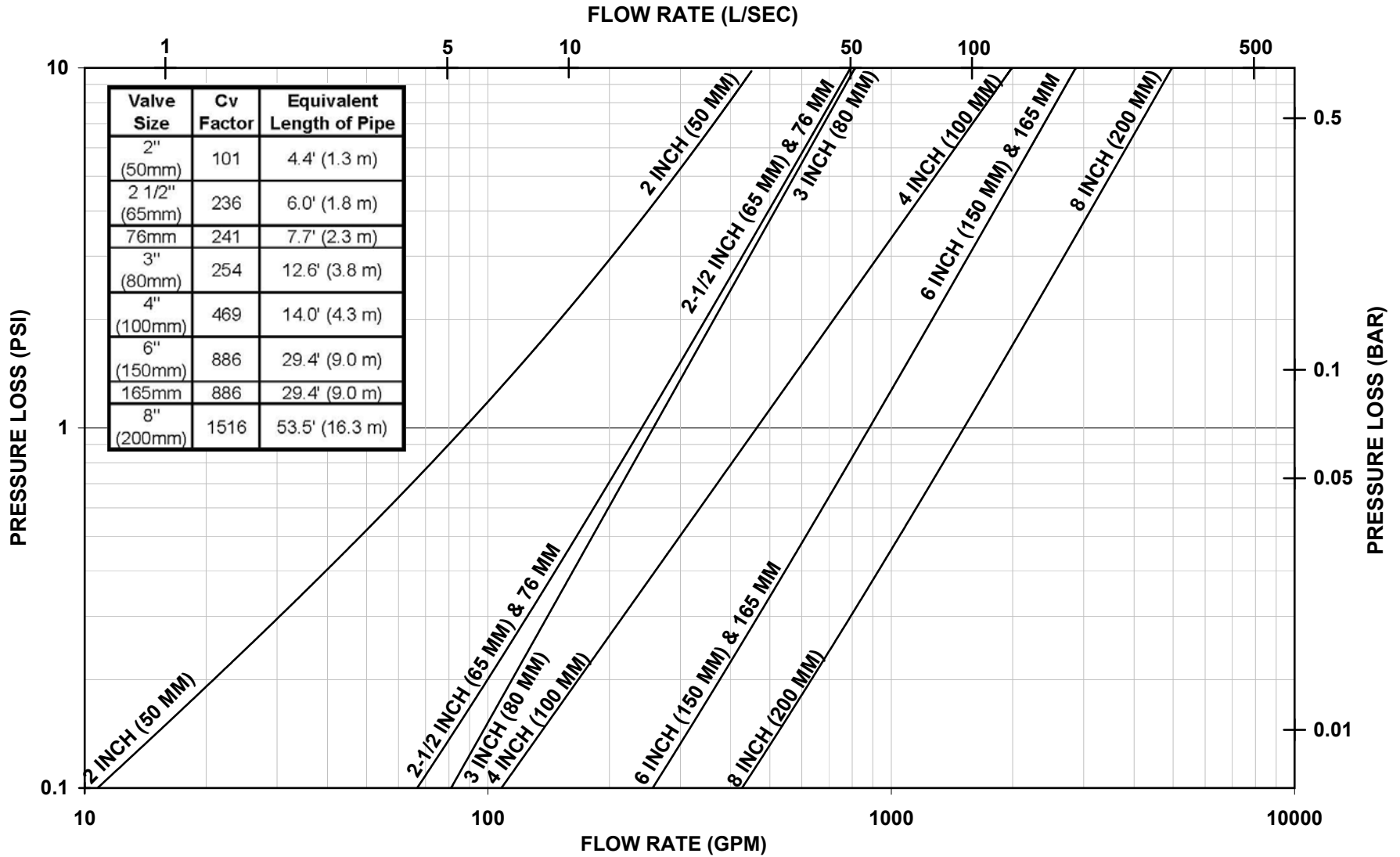

Fig. 2

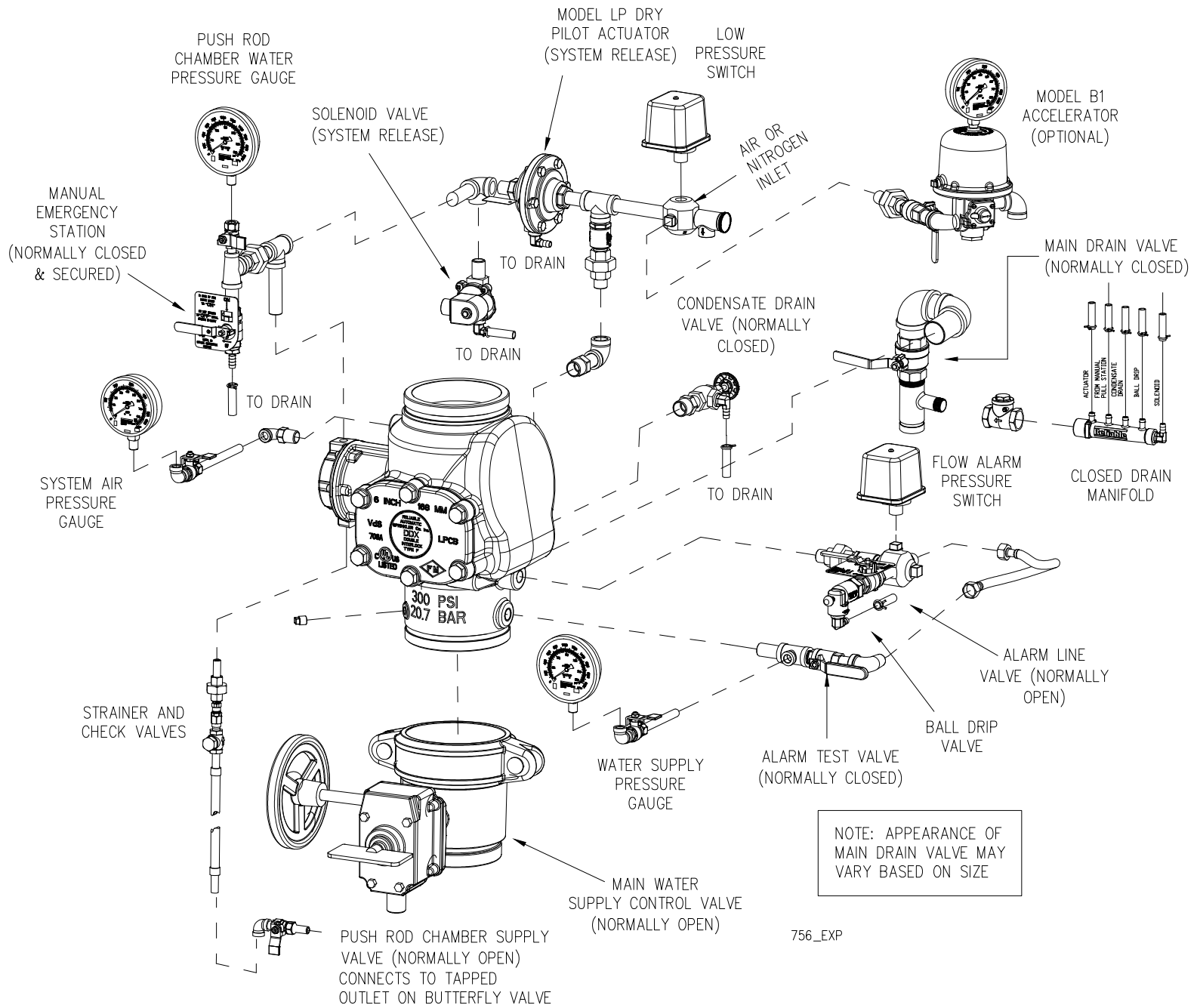

Fig. 3

## Model LP Dry Pilot Line Actuator Parts List

Item No.	Description
1	Lower Housing
2	Upper Housing
3	Seat
4	Diaphragm
5	Facing Plate Assembly
6	Diaphragm Washer
7	Facing Plate Nut
8	Seat O-Ring
9	Bolt
10	Compression Spring

**Note:** Parts list provided for information only. Available only as an assembly; individual parts are not available.

## Maintenance – Model LP Dry Pilot Line Actuator

If water constantly flows through the Model LP Dry Pilot Actuator, or if the actuator will not set up, the diaphragm/seal assembly may need replaced.

1. Close the main valve controlling water supply to the system, and close the air or nitrogen supply to the system.
2. Remove air or nitrogen pressure from the system.
3. Remove the actuator from the trim at the nearest convenient points.
4. Remove six bolts holding the actuator halves together.
5. Clean and inspect all interior surfaces. Replace the diaphragm/seal assembly.
6. Reassemble the actuator using a torque of 12 ft-lbs. on the six bolts in a cross-tightening pattern.
7. Reinstall the actuator and set up the system following the section “Resetting Model DDX Non-Interlock Praction Systems.”

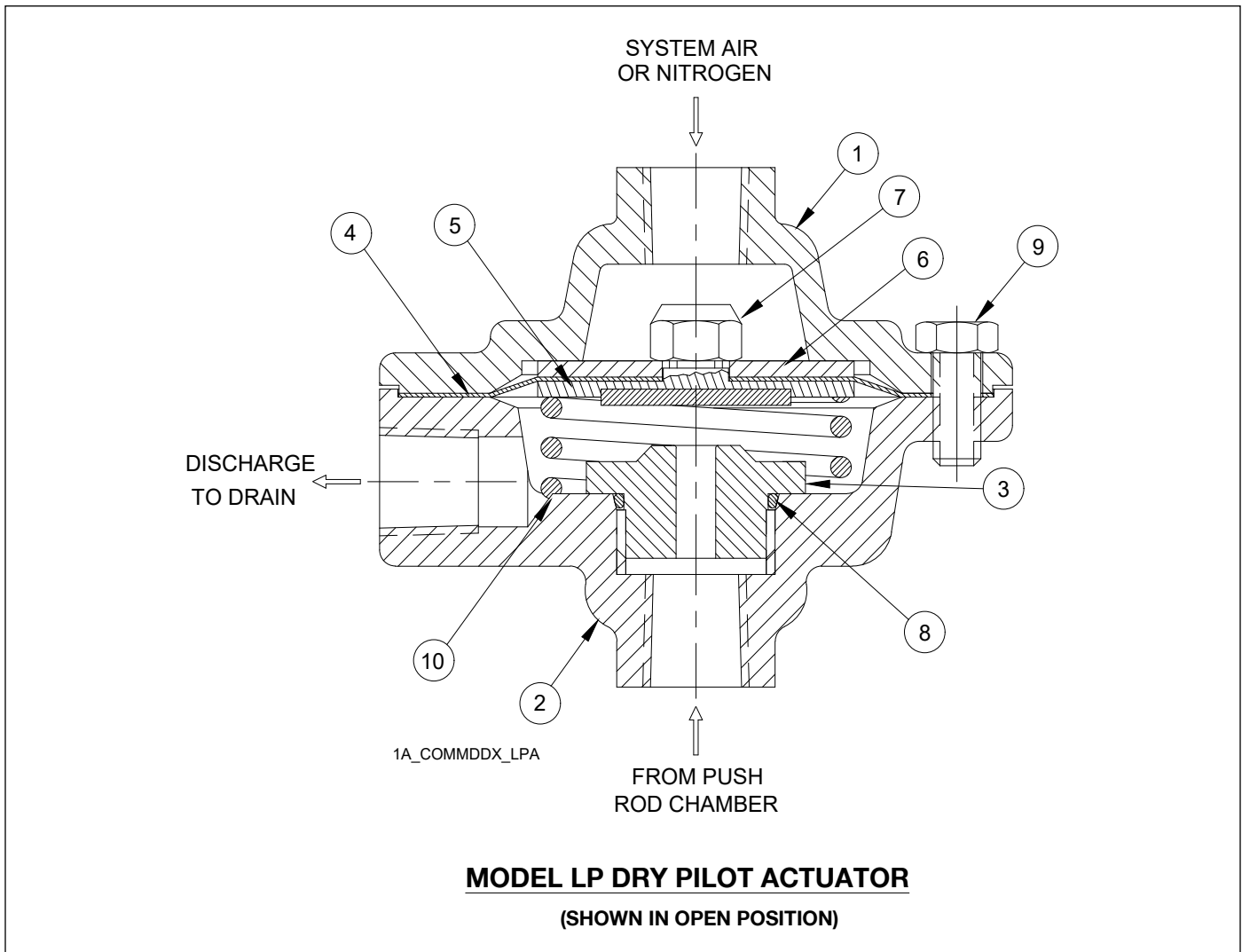

Fig. 4

## MODEL DDX VALVE WITH STAINLESS STEEL SCREW-IN SEAT

IMPORTANT NOTE: Early generation 4" and 6" DDX valves may incorporate a brass drop-in seat. Prior to ordering replacement parts, confirm the presence of a stainless steel screw-in seat or brass drop-in seat. For replacement parts for valves with brass drop-in seat, please contact Reliable Sprinkler Company Technical Services ([techserv@reliablesprinkler.com](mailto:techserv@reliablesprinkler.com))

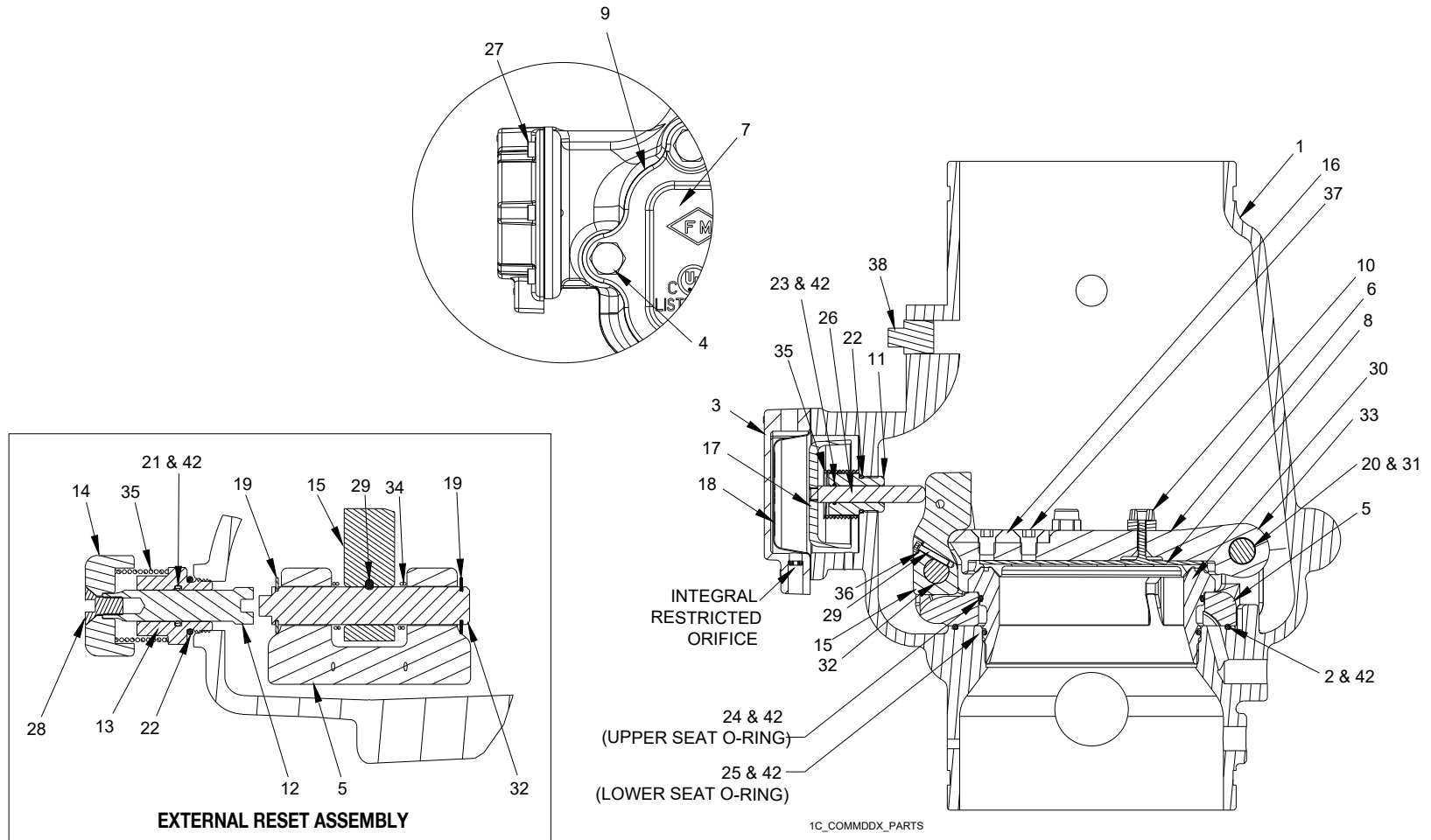

Fig. 5

## Model DDX (Screw-In Seat Configuration) Deluge Valves Parts List

Item No.	Part No.								Part Description	QTY.	Material	
	2" (50mm)	2½" (65mm)	76mm	3" (80mm)	4" (100mm)	165mm	6" (150mm)	8" (200mm)				
1	91006011	91006012	91006023	91006013	91006005	91006027	91006007	91006028	Valve Body Groove/Groove	1	Ductile Iron 65-45-12	
	N/A	N/A	N/A	N/A	91006045	N/A	91006067	N/A	Valve Body Flange/Groove			
	N/A	N/A	N/A	N/A	91006035	N/A	91006037	91006039	Valve Body Flange/Flange			
2	N/A	N/A	N/A	N/A	N/A	N/A	N/A	95406414	O-ring (Mounting Ring)	1	Buna-N	
3	71040416								Pushrod Cover Assembly	1	Ductile Iron 65-45-12 & Brass C360000	
4	91106123			N/A	N/A	N/A	N/A		Hex Bolt ½"-13 x 1¼"	6	Zinc Plated Steel	
	N/A			95606107	N/A	N/A	N/A		Hex Bolt ½"-13 x 1½"	6		
	N/A			N/A	91106006	N/A	N/A		Hex Bolt 5/8"-11 x 1¼"	6		
	N/A			N/A	N/A	95606110	N/A		Hex Bolt 5/8"-11 x 2"	8		
5	91306013			91306014	91306016	91306018	N/A		Mounting Ring	1	Stainless Steel CF8 or CF8M	
6	91916003			91916014	91916016	91916008	N/A		Clapper	1	Stainless Steel CF8 or CF8M	
7	92116063			92116064	92116065	92116066	92116068	N/A		Access Cover	1	Ductile Iron 65-45-12
8	93416003			93416014	93416016	93416008	N/A		Seal Assembly	1	Stainless Steel 304 & EPDM	
9	93706003			93706004	93706006	93706008	N/A		Access Cover Gasket	1	Buna-N or Neoprene	
10	93722000			93722000	N/A	N/A	N/A		Bumpstop Assembly	1	Stainless Steel UNS S31600 & EPDM	
	N/A			N/A	93722000	N/A	N/A			2		
	N/A			N/A	N/A	93722000	N/A			3		
11	93916006			N/A		N/A		N/A		Pushrod Guide	1	Acetal
12	93916066			N/A		N/A		N/A		Reset Shaft	1	Brass UNS C36000
13	94106066			N/A		N/A		N/A		Reset Housing	1	Brass UNS C36000
14	94356006			N/A		N/A		N/A		Reset Knob	1	Aluminum 6061
15	94506003			94506004	94506016	94506008	N/A		Lever	1	Stainless Steel UNS S17400	
16	95006412			94006412	95006410	95006410	N/A		Striker	1	Aluminum Bronze C95400	
17	95106006			N/A		N/A		N/A		Piston	1	Stainless Steel CF8M
18	95276006			N/A		N/A		N/A		Diaphragm	1	EPDM & Polyester
19	95306267			N/A	N/A	N/A	N/A		Retaining Ring, 3/8" Shaft, Lever Pin	2	Stainless Steel 15-7 or 17-7	
	N/A			95306267	N/A	N/A	N/A		Retaining Ring, 1/2" Shaft, Lever Pin			
	N/A			N/A	95306269	N/A	N/A		Retaining Ring, 5/8" Shaft, Lever Pin			
	N/A			N/A	N/A	95316408	N/A		Retaining Ring, 3/4" Shaft, Lever Pin			
20	95306268			N/A	N/A	N/A	N/A		Retaining Ring, 3/8" Shaft, Hinge Pin	2	Stainless Steel 15-7 or 17-7	
	N/A			95306267	95306267	N/A	N/A		Retaining Ring, 1/2" Shaft, Hinge Pin			
	N/A			N/A	N/A	95316408	N/A		Retaining Ring, 3/4" Shaft, Hinge Pin			
21	95406007			N/A		N/A		N/A		O-Ring, Reset Housing ID	1	Buna-N
22	95406024			N/A		N/A		N/A		O-Ring, Reset Housing & Pushrod Guide OD	2	Buna-N
23	95406407			N/A		N/A		N/A		O-Ring, Pushrod Guide ID	1	Buna-N
24	95406410			95406409	95436126	95406413	N/A		O-Ring, Upper Seat	1	Buna-N	
25	95406411			95406420	95446226	95406412	N/A		O-Ring, Lower Seat	1	Buna-N	
26	95506006			N/A		N/A		N/A		Pushrod	1	Stainless Steel UNS S30300
27	95606114			N/A		N/A		N/A		Socket Head Screw, 1/4"-20 x 5/8"	6	Steel
28	95606127			N/A		N/A		N/A		Flat Head Socket Cap Screw 3/8"-16 x 3/4"	1	Steel
29	95606133			N/A	N/A	N/A	N/A		Socket Head Screw #6-32 x 1/2"	1	Stainless Steel 18-8	
	N/A			95606130	95606130	95606130	N/A		Socket Head Screw #10-32 x 1"		Stainless Steel UNS S31600	
30	96016003			96016014	96016016	96016008	N/A		Seat	1	Stainless Steel CF8M	
31	96206003			N/A	N/A	N/A	N/A		Hinge Pin	1	Stainless Steel UNS S30400	
	N/A			96216086	96216086	96206008	N/A				Stainless Steel UNS S21800	
32	96216003			N/A	N/A	N/A	N/A		Lever Pin	1	Stainless Steel UNS S17400	
	N/A			96216044	96216047	96216008	N/A				Stainless Steel UNS S21800	
33	96310003			96906904	96906904	96310008	N/A		Clapper Spacer	2	Teflon or Acetal	

## Model DDX (Screw-In Seat Configuration) Deluge Valves Parts List (Continued)

Item No.	Part No.								Part Description	QTY.	Material	
	2" (50mm)	2½" (65mm)	76mm	3" (80mm)	4" (100mm)	165mm	6" (150mm)	8" (200mm)				
34	96406003			N/A		N/A		N/A		Lever Spring	1	Stainless Steel UNS S30400
	N/A			96406004		96406005		96406008				Stainless Steel UNS S31600
35	96406906								Piston/ Reset Spring	2	Stainless Steel UNS S31600	
36	96906112			N/A		N/A		N/A		Spring Lock Washer, #6	1	Stainless Steel 18-8
	N/A			96906111		96906111		96906111		Spring Lock Washer, #10		Stainless Steel UNS S31600
37	95606140			N/A		N/A		N/A		Flat Head Socket Cap Screw ¼"-20 x ½"	2	Stainless Steel 18-8
	N/A			95606139		N/A		N/A				Stainless Steel UNS S31600
	N/A			N/A		N/A		95606135		Flat Head Socket Cap Screw ½"-13 x ¾"		Stainless Steel UNS S31600
38	98604402								Plug, ½" NPT	1	Steel	
39	94616921								Knob Caution Label (Not Shown)	1	Polystyrene	
40	91556922								Ball Chain, 1/8" (Not Shown) (Length is in Inches)	6	Nickel Plated Brass	
41	91556923								Clamping Link, Ball Chain (Not Shown)	1		
42	699993406								O-Ring Grease, Dupont™ Krytox® GPL-205	A/R	Krytox®	

### Ordering Information

Specify:

#### Model DDX Non-Interlock Preaction System

- **Size**
- **End Configuration**
- **Trim Assembly**
  - Loose Trim
  - Segmentally Assembled
  - Fully Assembled no Control Valve
  - Fully Assembled with Control Valve  
(Available for grooved end valves only)
- **Optional 300 psi (20,7 bar) solenoid valve for electric release trim**

### Service Kits

Service kits are available for routine servicing of the valve (reference Figure 6). Service kits for the Model DDX Deluge Valve include the following components:

- Clapper Seal Assembly (item 8)
- Cover Gasket (item 9)
- Bumpstop(s) (item 10)
- Push rod chamber diaphragm (item 18)
- Grease (item 42)

**2", 2-1/2", and 3" Model DDX Service Kit: PN 6501200R03**

**4" Model DDX Service Kit: PN 6501200R04**

**6" Model DDX Service Kit: PN 6501200R05**

**8" Model DDX Service Kit: PN 6501200R06**

### Model DDX Valve with Non-Interlock Trim

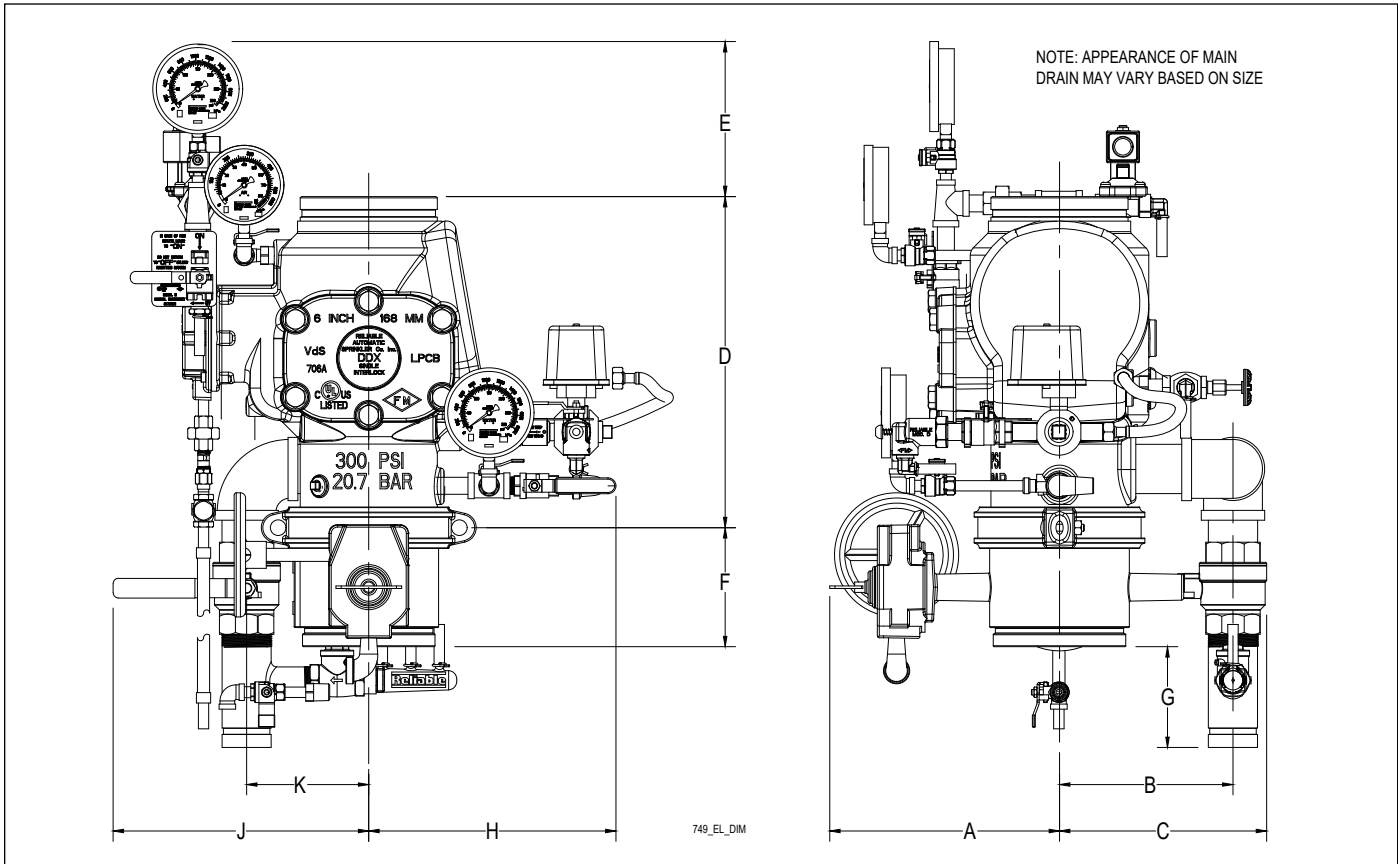

Fig. 6

Valve Size	Installation Dimensions in Inches (mm)										
	A	B	C	D <sup>(1)</sup>	D <sup>(2)</sup>	E	F <sup>(3)</sup>	G	H	J	K
2" (50)	8-1/2 (216)	7-3/4 (197)	9-1/8 (232)	12-1/2 (318)	NA	8-3/8 (213)	9-5/8 <sup>(4)</sup> (244)	1-1/2 (38)	10 (254)	9-1/2 (241)	4 (102)
2-1/2" (65), 3" (80), & 76mm	8-1/2 (216)	7-3/4 (197)	9-1/8 (232)	12-1/2 (318)	NA	8-3/8 (213)	3-7/8 (98)	1-3/8 (35)	9-7/8 (251)	9-1/2 (241)	3-7/8 (99)
4" (100)	9-3/4 (248)	7-5/8 (194)	9-1/4 (235)	14 (356)	16 (406)	7-1/4 (184)	4-9/16 (116)	5-1/4 (133)	11 (279)	11-7/8 (301)	5-1/2 (140)
6" (150) & 165mm	11-1/8 (283)	8-1/8 (206)	9-3/4 (248)	16 (406)	19 (483)	6-7/8 (175)	5-7/8 (149)	3-3/4 (95)	11 (279)	12 (305)	5-1/2 (140)
8" (200)	12-5/8 (321)	9 (229)	10-5/8 (270)	19-3/8 (492)	21-1/4 (540)	3-3/4 (95)	5-1/4 (134)	4-1/8 (105)	12-5/8 (306)	12 (305)	5-1/2 (140)

**Notes:**

1. End to end take out of Model DDX valve with grooved inlet.
2. End to end take out of Model DDX valve with flanged inlet where available (see page 10; also reference Bulletin 519).
3. Not applicable to 76mm or 165mm systems, or systems using a flanged inlet Model DDX valve.
4. 2" systems include spool piece with outlet below valve; dimension provided is total length of both components.

The equipment presented in this bulletin is to be installed in accordance with the latest published Standards of the National Fire Protection Association, Factory Mutual Research Corporation, or other similar organizations and also with the provisions of governmental codes or ordinances whenever applicable.

Products manufactured and distributed by Reliable have been protecting life and property for almost 100 years.

Manufactured by



**Reliable Automatic Sprinkler Co., Inc.**

(800) 431-1588  
 (800) 848-6051  
 (914) 829-2042  
 www.reliablesprinkler.com

Sales Offices  
 Sales Fax  
 Corporate Offices  
 Internet Address



Revision lines indicate updated or new data.

EG. Printed in U.S.A. 01/25 P/N 999970701