

Reliable®

Model FCA Floor Control Assembly

For Use in NFPA 13 and NFPA 13R Systems

cULus Listed

Features

- Compact design
- Grooved component connections for universal application
- Horizontal (check valve hinge up) and vertical (flow up) installation

Product Description

The Reliable Model FCA Floor Control Assembly is designed for use as a floor or zone control assembly in NFPA 13 or 13R applications. The product can also be used as a conventional wet system (shotgun) riser. Grooved connections on each component allow components to be rotated independently, providing maximum flexibility in the field. The assembly includes a butterfly control valve with integral tamper switch, a water flow detector, and a riser check valve with a pressure gauge and a Model TD Test & Drain valve. Multiple orifices and pressure relief options are available for the Model FCA Floor Control Assembly.

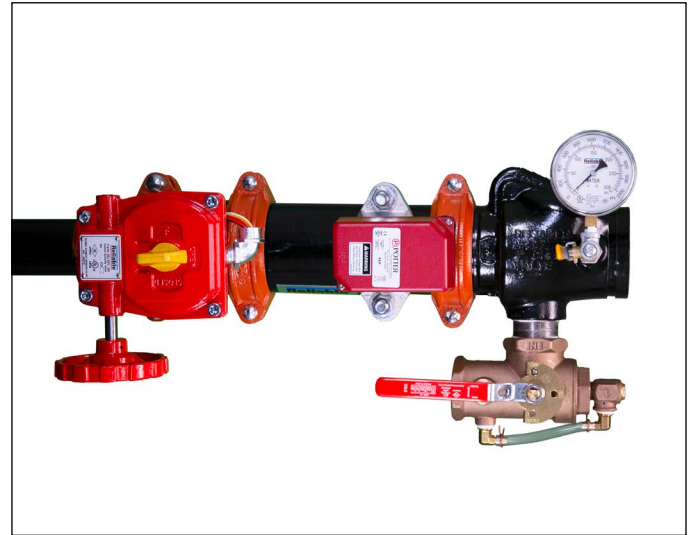

Model FCA Valve

Model FCA Technical Data

Table A

Size	Takeout (Length)	Pressure Rating	Weight
2" (50mm)	19-3/4" (502mm)	300 psi (20,7 bar)	26 lbs (11.8 kg)
2-1/2" (65mm)	21-1/4" (5402mm)	250 psi (17,2 bar)	40 lbs (18.1 kg)
3" (80mm)	21-3/4" (552mm)	250 psi (17,2 bar)	46.5 lbs (21.1 kg)
4" (100mm)	23-1/2" (597mm)	250 psi (17,2 bar)	62 lbs (28.1 kg)

Model FCA Equivalent Length of Schedule 10 Pipe

Table B

Size	C = 120
2" (50mm)	16.6
2-1/2" (65mm)	14.0
3" (80mm)	16.3
4" (100mm)	20.1

Model FCA Dimensions (Refer to Table D)

Figure 1

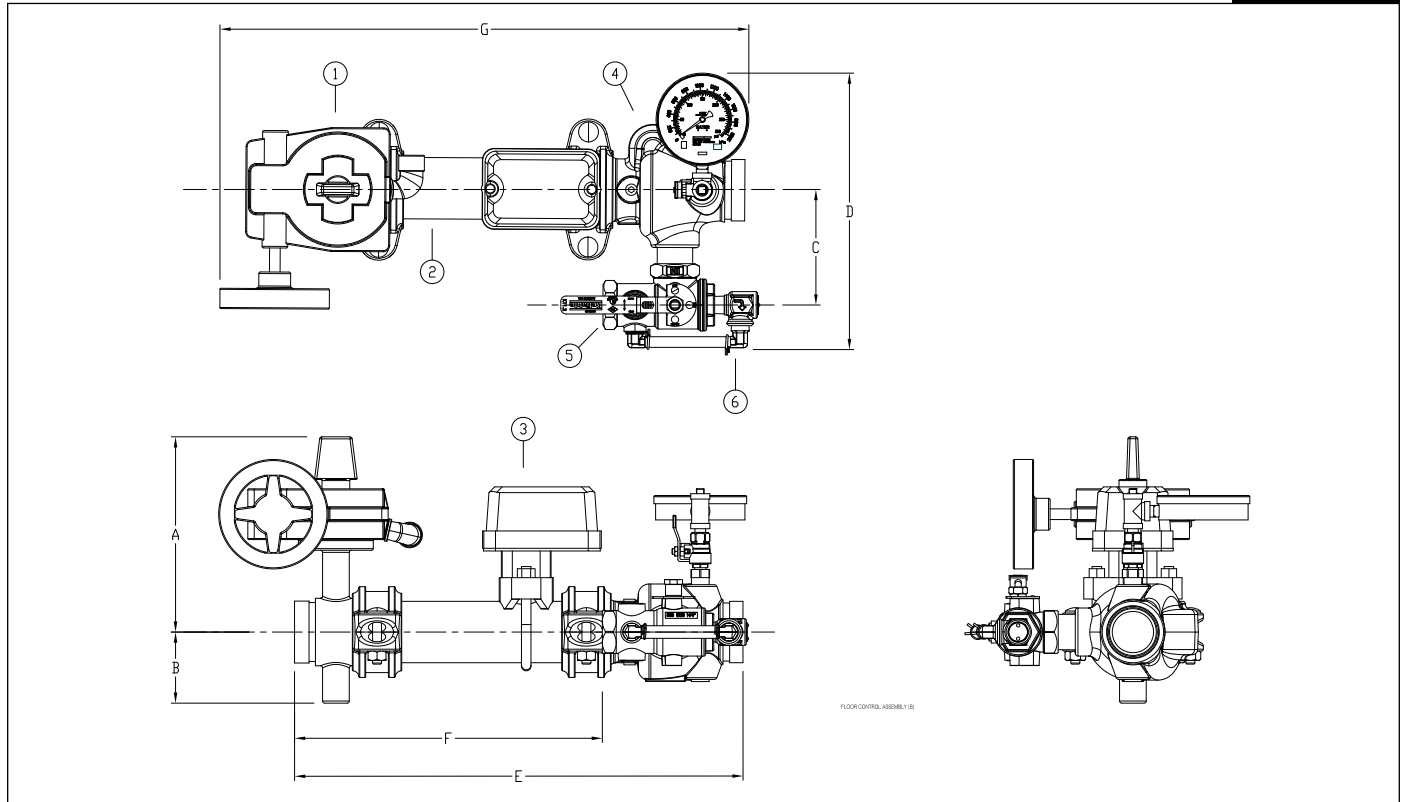

Model FCA Dimensions (Refer to Figure 1)

Table C

Size	A	B	C	D	E	F	G
2" (50mm)	6-3/4" (171mm)	3" (76mm)	5" (127mm)	15-3/4" (400mm)	19-3/4" (502mm)	13-1/2" (343mm)	21-1/2" (546mm)
2-1/2" (65mm)	9-1/4" (235mm)	3-1/4" (83mm)	5-1/4" (133mm)	15-1/2" (140mm)	21-1/4" (540mm)	14-1/2" (368mm)	24-1/2" (622mm)
3" (76mm)	9-1/2" (241mm)	3-1/2" (89mm)	5-1/2" (140mm)	16-3/4" (425mm)	21-3/4" (552mm)	14-1/2" (368mm)	24-1/2" (622mm)
4" (100mm)	10-1/2" (267mm)	4-1/4" (108mm)	7" (178mm)	20" (508mm)	23-1/2" (597mm)	14-1/2" (368mm)	26-1/2" (673mm)

Components (Refer to Figure 1)

Table D

Item	Description
1	Grooved Butterfly Valve
2	Manifold
3	Water Flow Switch
4	Riser Check Valve
5	Test and Drain Valve
6	Pressure Relief Valve

Installation

The Reliable Model FCA Floor Control Assembly shall be installed in accordance with NFPA 13, NFPA13R, and the requirements of any authorities having jurisdiction. Failure to follow installation instructions and/or revisions to the arrangement of the devices may void the warranty and/or listing of the product. Prior to installation, verify compatibility of the Model FCA materials with the water supply and the environment where the valve will be installed. The Model FCA must be installed in a location where the temperature is maintained at a minimum of 40°F (4°C). Heat tracing of wet system valve assemblies is prohibited by NFPA 13.

Connect the inlet of the device to the water supply and the outlet of the device to the fire protection system. Ensure proper direction of flow using the diagrams contained in this bulletin and on the device. Drain should be piped to a location that will avoid damage to property and injury to personnel.

Maintenance

The owner is responsible for maintaining the fire protection system in proper operating condition. Any system maintenance or testing that involves placing a control valve or detection/control system out of service may eliminate the fire protection that is provided by the fire protection system. Notify any required authorities having jurisdiction and implement appropriate precautions prior to proceeding.

When required, the Reliable Model FCA Floor Control Assembly and associated equipment shall periodically be given a thorough inspection and test. NFPA 25, "Inspection, Testing and Maintenance of Water Based Fire Protection Systems," provides minimum maintenance requirements. Replace any components found to be corroded, damaged, or worn. Increase the frequency of inspections when the valve is exposed to corrosive conditions or chemicals that could impact the valve materials.

Guarantee

For Reliable Automatic Sprinkler, Co., Inc. guarantee, terms, and conditions, visit www.reliablesprinkler.com.

Ordering Information

Specify:

- Reliable Model FCA Floor Control Valve Assembly
- Size: [2", 2-1/2", 3" or 4"]
- Orifice Size (K Factor) for Test and Drain Valve:
 - [2" FCA: 4.2 (60), 5.6 (80), 8.0 (115), or 11.2 (160)]
 - [2-1/2", 3", and 4" FCA: 2.8 (40), 5.6 (80), 8.0 (115), 11.2 (160), or 16.8 (240)]
- Pressure Relief Valve Kit for Test and Drain Valve:
 - [175, 185, 210, 260, or 310 psi for 2" FCA]
 - [175, 185, 210, or 260 psi for 2-1/2", 3", and 4" FCA]

FCA Floor Control Assembly Ordering Information Part Number

Figure 2

6B XX 00 P YY Z

Riser Check & Manifold Size ⁽¹⁾ XX	Drain Valve Options ⁽¹⁾ YY	Pressure Relief Valve Options ⁽²⁾ Z
20 = 2"	01 = 1" RASCO T&D Valve (K2.8) 02 = 1" RASCO T&D Valve (K4.2) 03 = 1" RASCO T&D Valve (K5.6)	1 = 175psi 2 = 185psi 3 = 210psi
25 = 2-1/2" 30 = 3"	04 = 1-1/4" RASCO T&D Valve (K4.2) 05 = 1-1/4" RASCO T&D Valve (K5.6) 06 = 1-1/4" RASCO T&D Valve (K8.0) 07 = 1-1/4" RASCO T&D Valve (K11.2)	4 = 260psi 5 = 310psi
40 = 4"	08 = 2" RASCO T&D Valve (K5.6) 09 = 2" RASCO T&D Valve (K8.0) 10 = 2" RASCO T&D Valve (K11.2) 11 = 2" RASCO T&D Valve (K16.8) 12 = 2" RASCO T&D Valve (K2.8)	

Note:

⁽¹⁾ 2" FCA has a 1" drain outlet, 2-1/2" and 3" FCA have a 1-1/4" drain outlet, and 4" FCA has a 2" drain outlet.

⁽²⁾ Pressure Relief Valve option #5 is not available for sizes 2-1/2", 3", and 4" FCA.