

Reliable®

Model A Dry Pipe Valve

Instructions for Installation, Operation Care and Maintenance

2 1/2" (65mm) Valve with Model A Trim

Listed by Underwriters Laboratories, Inc. Approved by Factory Mutual Research Corporation, and other fire insurance and governmental agencies in the United States and foreign countries.

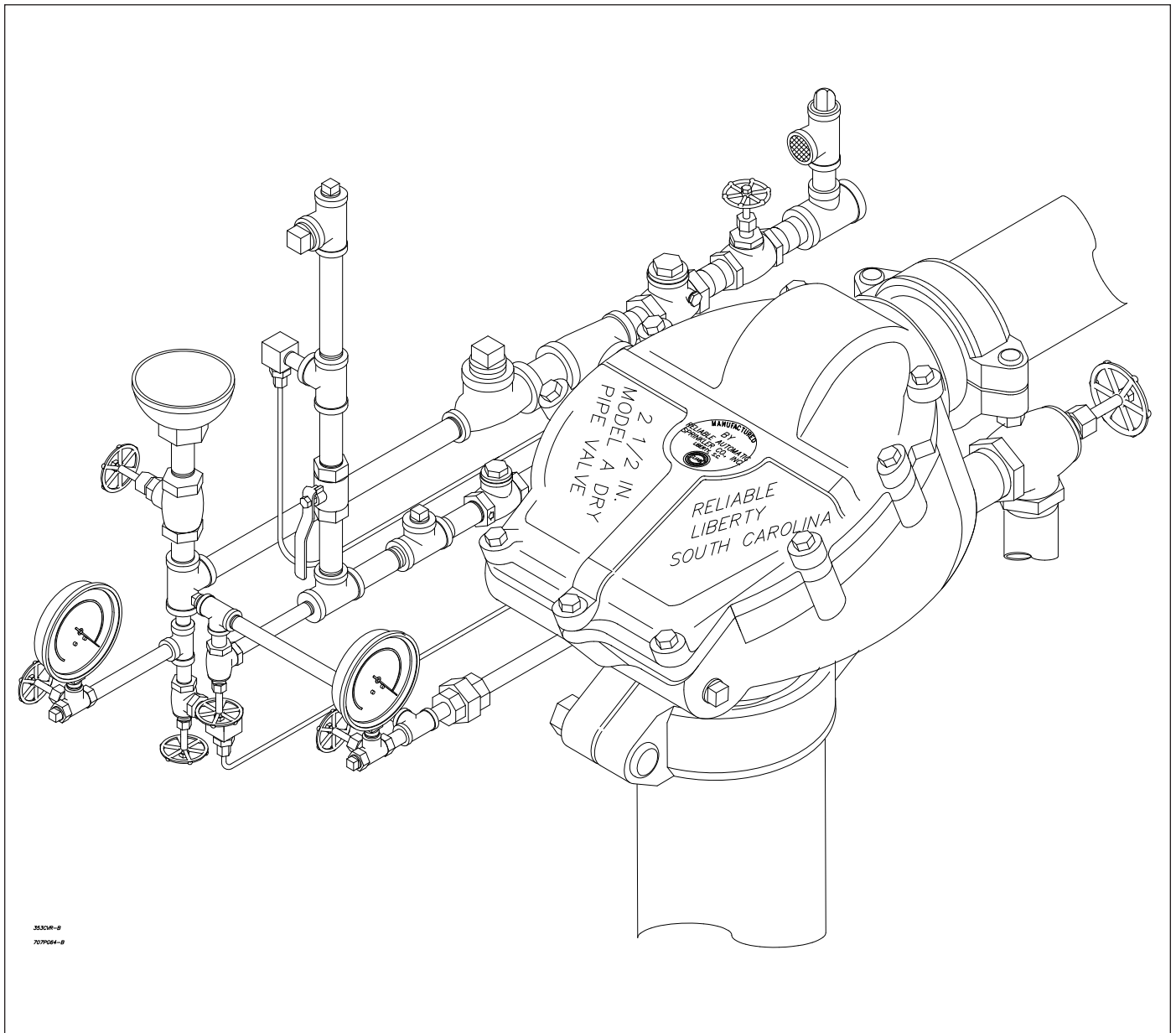

3530R-9
707064-9

General

The Model A Dry Pipe Valve is installed with the inlet vertical in the main supply to the dry pipe system. The Basic Trim Set, Priming Chamber Attachment and Fill Line Attachment are described here but are separately ordered and supplied. Additional items such as Air Maintenance Devices, Air Compressors, Alarm Switches, etc. are described and installed in accordance with their respective product bulletins.

Valve Description

1. Rated working pressure 175 psi (12, 3 bar)
2. Factory hydrostatic test pressure 350 psi (24, 6 bar)
3. End and trim connections—Three valve connection styles are available.
 - A. 2½" American Standard taper pipe threads inlet and outlet per ANSI B 2.1
 - Threaded openings per ANSI B 2.1
 - Reliable's standard trim sets are compatible with American Standard taper pipe threads
 - Color—Light Gray
 - B. 2½" US Grooved Inlet and Outlet.

| | |
|-------------------------|---------|
| • Outlet Dia. | — 2.875 |
| • Groove Dia. | — 2.72 |
| • Groove Width | — 5/16 |
| • Outlet Face To Groove | — 5/8 |

 - Threaded openings per ANSI B 2.1
 - Reliable's standard trim sets are compatible with Grooved Valves
 - Color—Light Gray
 - C. 2½" (65mm) Metric pipe threads inlet and outlet per BS 21-1973
 - Threaded openings per BS 21-1973
 - Reliable's standard trim sets may be used with metric valves. Trim should be assembled carefully and extra thread sealant is applied to connections between valves and trim.
 - Color—Red.
4. Shipping Weight—60 lbs. (27 kg)
5. Friction loss—Expressed in Equivalent Length of Pipe, based on Hazen & Williams Formula with C = 120. Equiv. Length—9.5' (2.9m)
6. Installation position: Inlet must be vertical

Assembly of Model A Trim

All valves are listed and approved by Underwriters Laboratories, Inc. and Factory Mutual Research Corp. only when used with the valve manufacturers trim sets.

Basic Trim

The assembled basic trim set is shown in Fig. 2.

1. Install ¼" Nipple (Item 27) in tapped opening marked "Test" and attach half of ¼" Union (Item 31).
2. Install ½" Nipple (Item 24) in tapped opening marked "Alarm" and connect parts in proper order through Check Valve (Item 6).

Note: Install Check Valve (Item 26) to allow flow from the Dry Pipe Valve to the alarm line. Continue trimmings to the opposite side half of Union (Item 31).
3. Connect the rest of trimming parts in any desired order.

4. A Model B Strainer must be installed, as shown, whenever a Model C Mechanical Watermotor Alarm is used. The Strainer must be in a horizontal line to protect the nozzle in the Watermotor, and it must be accessible for cleaning.

Drain Pipe from Drip Cup (Item 18) should be run as directly as possible to an open drain. If it is absolutely necessary to connect it to the Main Drain Line, install a Check Valve in the Drip Cup drain line at least 4 feet below the Drip Cup so as to give proper head for discharge of water into the Main Drain Line. See NFPA 13 for additional requirements.

Priming Chamber and Fill Line Attachments

The assembled Priming Chamber and Fill Line Attachments are shown in Fig. 3.

Hydrostatic Testing of Dry Pipe System

When conducting hydrostatic tests of system piping at pressures in excess of 50 psi, be sure the Dry Pipe Valve Clapper is either latched in wide open position or removed from valve. Otherwise, injury to the valve may occur.

Operation

The normal position of the Dry Pipe Valve parts is shown in Fig. 4.

When the system air pressure drops, due to opening of one or more sprinklers, the Clapper (5), through the greater force exerted on its underside by the water supply pressure, moves upward rotating to its open position. It is held automatically in this position by Latch. Supply water instantly flows through the Dry Pipe Valve into the sprinkler system piping. Water also flows through the Alarm Outlet to the Electric Alarm Switch and Water Motor causing automatically an alarm to be sounded.

Automatic Air Maintenance Devices

The use of an Automatic Air Maintenance Device is strongly recommended with any dry system. It becomes a necessity when the system is as small as that associated with a 2½" (65 mm) inch size valve. Typically, these systems may have a capacity of only 10 - to - 25 gallons. In a system with such a small amount of compressed air, even a very tiny leak could drop the air pressure to a point where the Dry Pipe Valve would operate.

The use of an Automatic Air Maintenance Device compensates for these small leaks and maintains the system at a safe pressure. However, it is especially designed to not retard the operation of the Dry Pipe Valve when a sprinkler does open.

Reliable's Model A-2 and Model B-1 Automatic Air Maintenance Devices are described in greater detail in a separate bulletin (254).

Because of the small sizes of systems usually associated with a 2½" (65 mm) size Dry Pipe Valve, the use of a quick opening device is not recommended. A slight leak in a small system could cause an Accelerator to operate thereby operating the Dry Pipe Valve prematurely.

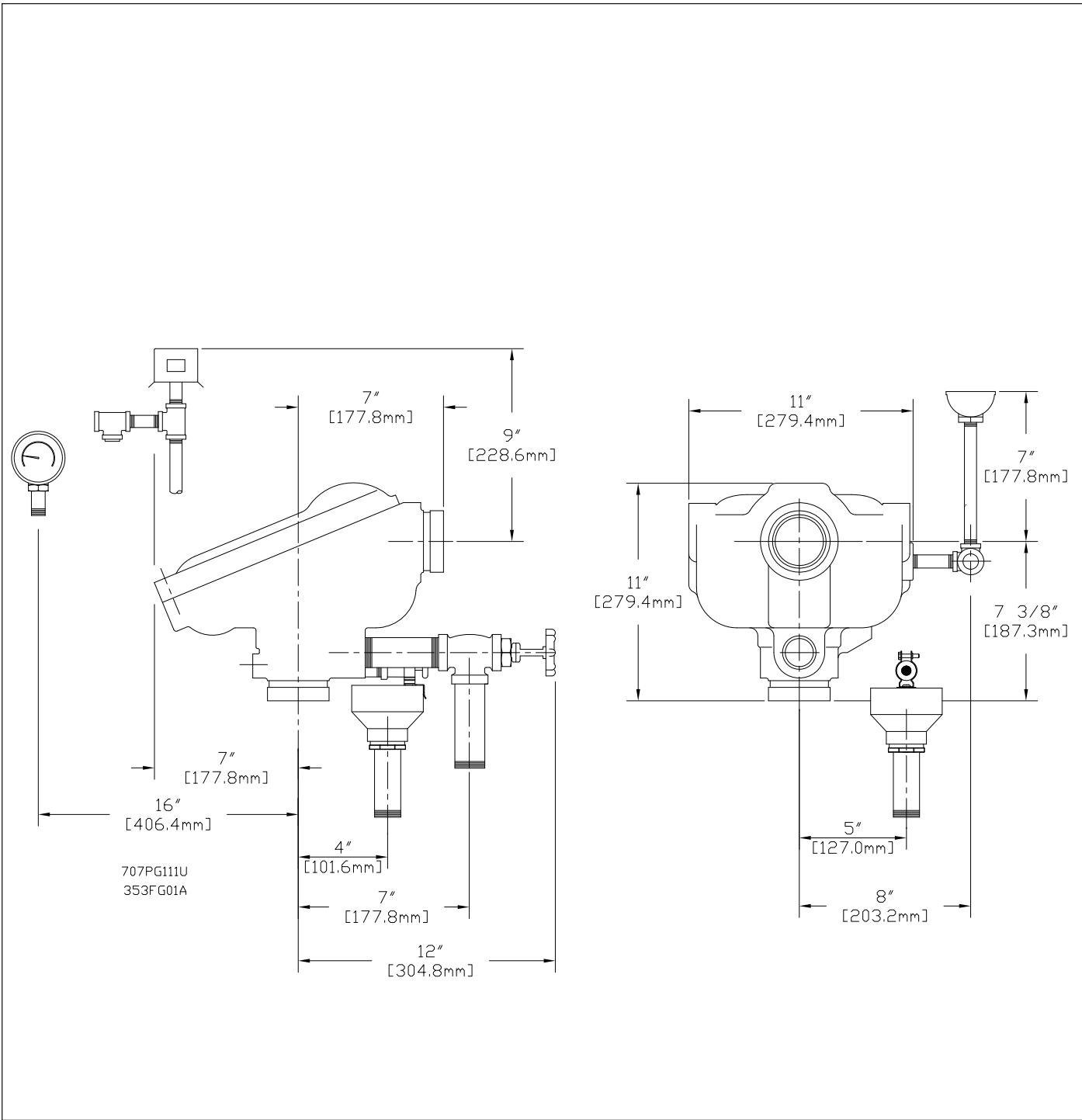

Fig. 1 - Installation Dimensions in Inches (mm)

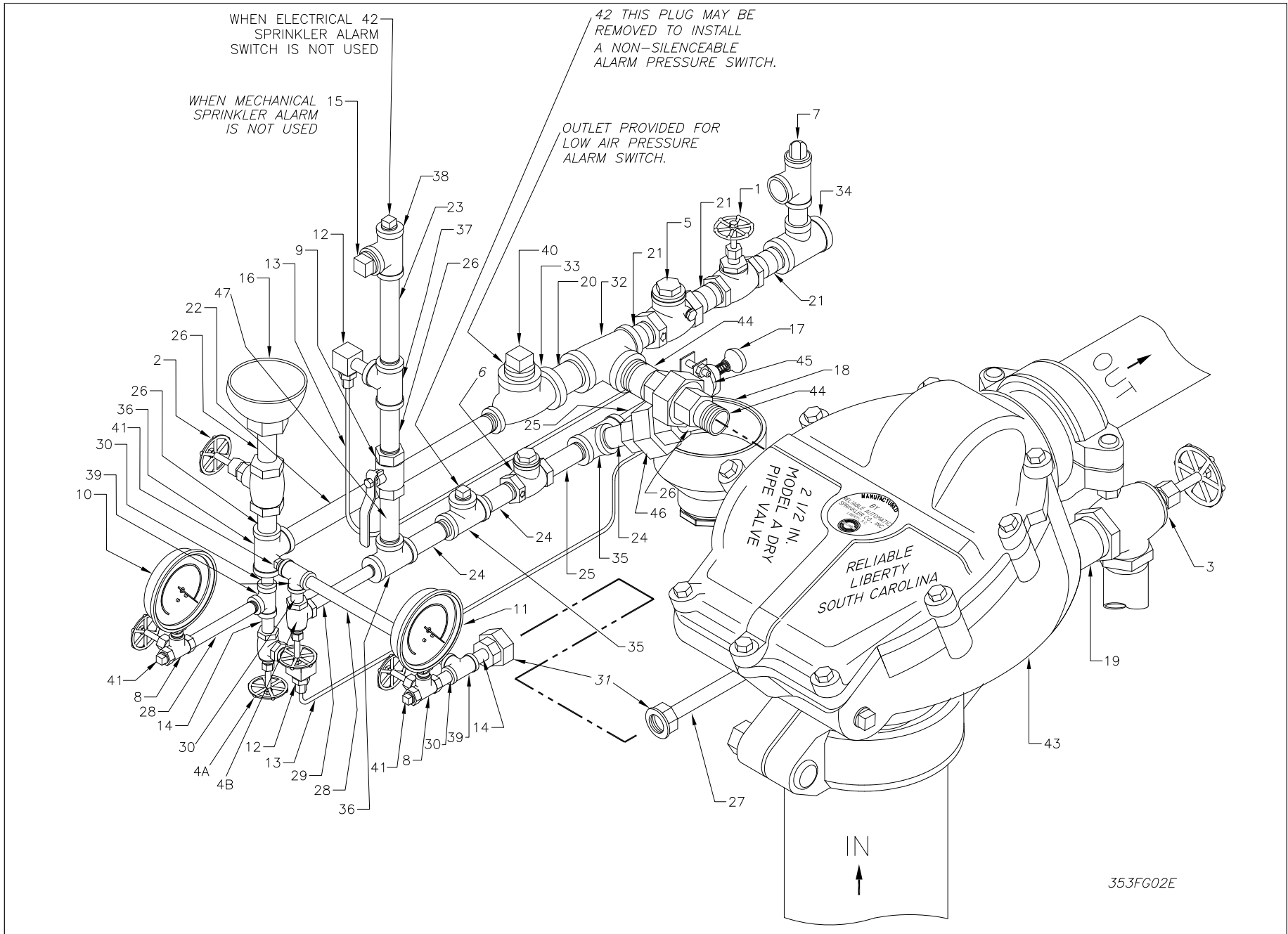

Fig. 2 - Model "A" Dry Pipe Valve with Model A Trim (without priming chamber & fill line attachment)

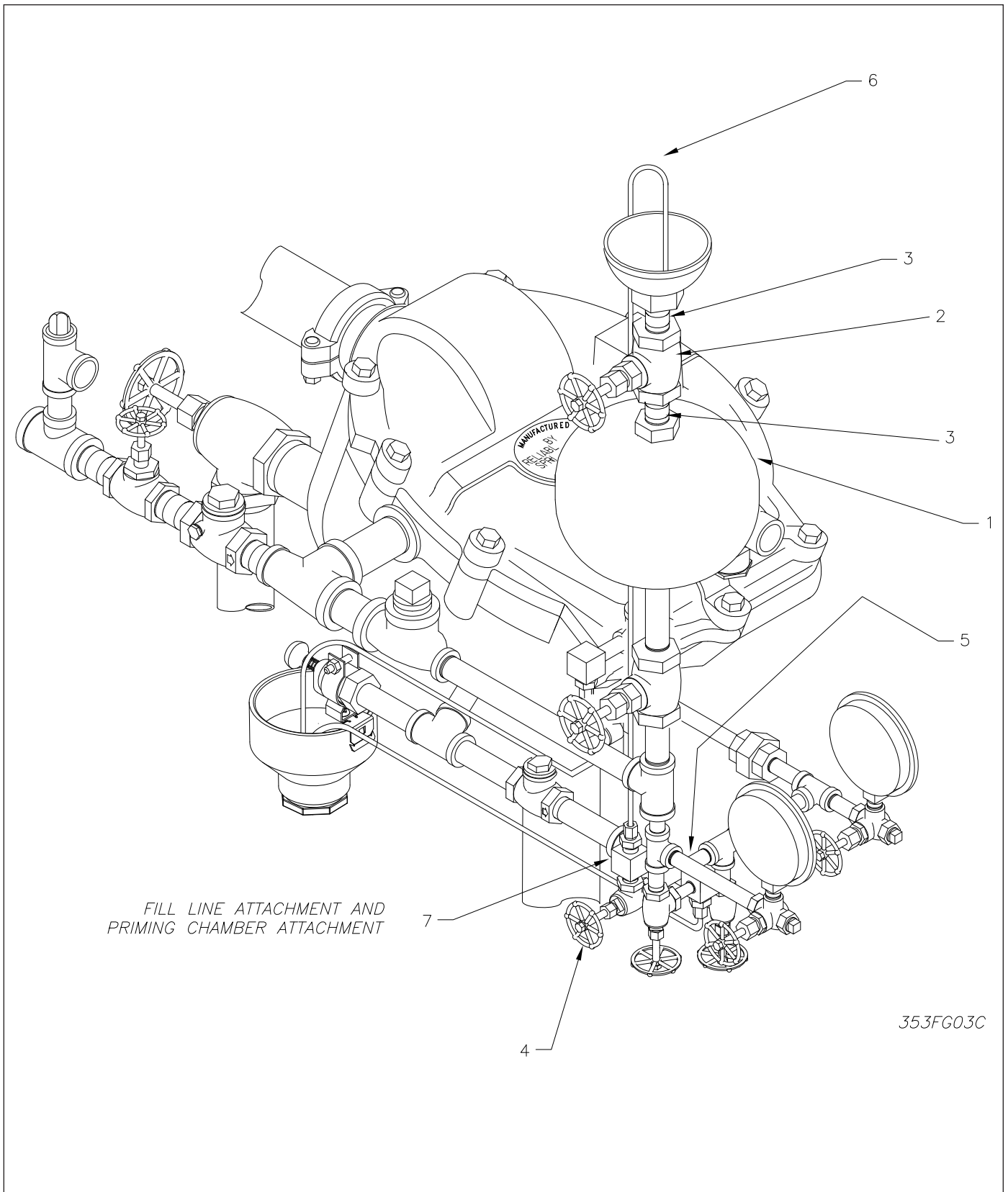

Fig. 3 - Priming Chamber Attachment & Fill Line Attachment

Reliable Model A Dry Pipe Valve with Model A Trim (Fig. 2)
Trim Parts Without Priming Chamber & Fill Line Attachment - P/N 6501090100 (Loose)
P/N 6501101010 (Seg)

| Item No. | Part No. | Description | No. Req'd |
|----------|----------|--|-----------|
| 1 | 98840170 | Globe Valve Bronze 3/4" | 1 |
| 2 | 98840171 | Globe Valve Bronze 1/2" | 1 |
| 3 | 98840106 | Angle Valve Bronze 1 1/4" | 1 |
| 4 | 98840101 | Angle Valve Bronze 1/4" | 2 |
| 5 | 98840180 | Horizontal Check Valve 3/4" | 1 |
| 6 | 98840181 | Horizontal Check Valve 1/2" | 1 |
| 7 | 98840190 | Relief Valve 1/2" | 1 |
| 8 | 98840160 | Three Way Valve 1/4" | 2 |
| 9 | 98840105 | Ball Valve 1/2" | 1 |
| 10 | 98248000 | Air Pressure Gauge 1/4" | 1 |
| 11 | 98248001 | Water Pressure Gauge 1/4" | 1 |
| 12 | 98164406 | Ell Brass Male Comp. Type 3/16" x 1/4" | 2 |
| 13 | 98768001 | Tubing Copper 3/16" x 42" | 2 |
| 14 | 98543244 | Nipple, 1/4" x 2" | 2 |
| 15 | 98614401 | Plug 3/4" | 1 |
| 16 | 75000050 | Priming Cup 1/2" | 1 |
| 17 | 78653100 | Ball Drip Valve | 1 |
| 18 | 71010471 | Drip Cup Assembly 1 1/4" | 1 |
| 19 | 98543239 | Nipple, 1 1/4" x 3" | 1 |
| 20 | 98543214 | Nipple, 1" x 2" | 1 |
| 21 | 98543215 | Nipple, 3/4" x 1 1/2" | 3 |
| 22 | 98543237 | Nipple 1/2" x 8" | 1 |
| 23 | 98543207 | Nipple 1/2" x 4" | 1 |
| 24 | 98543212 | Nipple 1/2" x Close | 3 |
| 25 | 98543209 | Nipple 1/2" x 2" | 2 |
| 26 | 98543223 | Nipple 1/2" x 1 1/2" | 4 |
| 27 | 98543217 | Nipple 1/4" x 6" | 1 |
| 28 | 98543218 | Nipple 1/4" x 3 1/2" | 2 |
| 29 | 98543226 | Nipple 1/4" x 1 1/2" | 1 |

| Item No. | Part No. | Description | No. Req'd |
|----------|------------|---|-----------|
| 30 | 98543227 | Nipple 1/4" x Close | 3 |
| 31 | 98815201 | Union 1/4" | 1 |
| 32 | 96606602 | Tee 1" x 3/4" x 1" | 1 |
| 33 | 96606613 | Tee 1" x 1/2" x 1" | 1 |
| 34 | 96606604 | Tee 3/4" x 3/4" x 1/2" | 1 |
| 35 | 98761651 | Tee 1/2" x 1/2" x 1/2" | 2 |
| 36 | 98761649 | Tee 1/2" x 1/4" x 1/2" | 2 |
| 37 | 96606607 | Tee 1/2" x 1/2" x 1/4" | 1 |
| 38 | 96606603 | Tee 1/2" x 1/2" x 3/4" | 1 |
| 39 | 96606608 | Tee 1/4" x 1/4" x 1/4" | 3 |
| 40 | 98614400 | Plug 1" | 1 |
| 41 | 98614403 | Plug 1/4" | 3 |
| 42 | 98604406 | Plug 1/2" | 2 |
| 43 | 6101020000 | Assy, Mod. A 2 1/2" Dry Pipe Valve Threaded | 1 |
| | 6101020015 | Assy, Mod. A 2 1/2" Dry Pipe Valve Grooved | |
| 44 | 98543213 | Nipple, 1" Closed | 2 |
| 45 | 98815207 | Union, 1" | 1 |
| 46 | 98815200 | Union, 1/2" | 1 |
| 47 | 98543230 | Nipple, 1/2" x 3" | 1 |

Priming Chamber Attachment (Fig. 3)
P/N 6501080100

| Item No. | Part No. | Description | No. Req'd |
|----------|----------|--------------------------|-----------|
| 1 | 71010432 | Priming Chamber | 1 |
| 2 | 98840171 | Globe Valve 1/2" | 1 |
| 3 | 98543223 | Nipple 1/2" x 1 1/2" | 2 |
| 4 | 98840101 | Angle Valve Bronze, 1/4" | 1 |

Fill Line Attachment (Fig. 3)
P/N 6501110000

| Item No. | Part No. | Description | No. Req'd |
|----------|----------|-----------------------------------|-----------|
| 5 | 98543226 | Nipple, 1/4" x 1 1/2" | 1 |
| 6 | 98768002 | Tubing Copper, 1/4" x 48" | 1 |
| 7 | 98085630 | Brass Male Comp. Type 1/4" x 1/4" | 1 |

Water-Air Pressure Table II

| Water Pressure in Supply Line psi (bar) | Air Pressure to be Pumped into System psi (bar) | | Water Pressure in Supply Line psi (bar) | Air Pressure to be Pumped into System psi (bar) | |
|---|---|---------------|---|---|---------------|
| | Not Less Than | Not More Than | | Not Less Than | Not More Than |
| Maximum | Not Less Than | Not More Than | Maximum | Not Less Than | Not More Than |
| 20 (1.38) | 10 (0.68) | 20 (1.37) | 125 (8.62) | 30 (2.06) | 40 (2.75) |
| 50 (3.44) | 15 (1.03) | 25 (1.72) | 150 (10.34) | 35 (2.41) | 45 (3.10) |
| 75 (5.17) | 20 (1.37) | 30 (2.06) | 175 (12.06) | 40 (2.75) | 50 (3.44) |
| 100 (6.89) | 25 (1.72) | 35(2.41) | | | |

Note: Maximum Water Pressure to which the system is liable to be subjected should be taken instead of normal pressure. Fire pumps usually give at least 100 psi (6.89 bar).

Maintenance

Dry pipe systems shall be tested and maintained in accordance with NFPA 25, which provides minimum inspection, testing and maintenance requirements. These requirements include:

- Quarterly inspection and maintenance of prime water levels
- Quarterly main drain flow test
- Quarterly waterflow and low air alarm test
- Draining of all low point drains as frequently as necessary
- Annual dry pipe valve trip test, inspection cleaning, parts renewal as required and valve reset.

Resetting Dry Pipe Valve

Figs. 2 and 4 show the trim and valve parts in their normal position.

1. Close Valve controlling water supply to Dry Pipe Valve.
2. Open Main Drain Valve (Item 3 - Fig 2) and drain system.
3. Open all Drain Valves (remove Plugs) and open vents at low points throughout the system, closing them when flow of water has stopped.
4. Push in Plunger of Ball Drip Valve (Item 17 - Fig 2) to force ball from its seat.
5. Remove Drain Plug (Item 9 - Fig 4) to drain body of Dry Pipe Valve. Replace Drain Plug securely when flow of water has stopped.
6. Remove Cover (Item 3 - Fig 4) and raise Clapper (Item 5 - Fig 4) as far as possible. Thoroughly clean air and water seats making certain that they are free from scale, dirt, lint, etc. Inspect and clean or replace rubber facing. NEVER APPLY GREASE, COMPOUND, SHELLAC, OR ANY OILY SUBSTANCES TO SEATS OR RUBBER FACING.

Note: If replacement is necessary, see parts removal.

7. Release Lever Latch by holding clapper slightly above the latch stop in the body. Push the front tip of the latch down and hold the latch in this tipped position. Lower the clapper onto the seat.
8. Center the locating diameter of the Clapper Rubber Facing (Item 12 - Fig 2) around the water seat. The clapper (Item 5 - Fig 4) should sit flat and with a minimum of movement when the seating is correct. Pressing down on the clapper may help to accomplish the locating and seating of the clapper.
9. Replace Gasket (Item Item 4 - Fig 4 - Fig 2) and Cover (Item 3 - Fig 4) and uniformly tighten cover bolts (Item 2 - Fig 4).
10. Open Valve (Item 2 - Fig 2). Fill body of Dry Pipe Valve with water through Priming Cup (Item 16 - Fig 2) until water flows in Drip Cup (Item 18 - Fig 2) from Valve (Item 4A - Fig 2). Showing that priming water is at the proper level, close Valve (Item 2 - Fig 2) and (Item 4A - Fig 2). If priming water flows out of the ball drip valve, this means that the rubber facing is not sealing at the air (outer) seat. To correct this, return to

step (6), remove the cover and re-inspect the rubber facing. Replace the facing if required. If the facing appears acceptable, it may be deformed. Pull the outer edge of the rubber down, away from the clapper so that the rubber contacts the air seat when the clapper is reset.

Note: When Dry Pipe Valve is equipped with Priming Chamber Attachment (Fig. 3, item 1), follow same procedure, but open and close Valves (2 in Fig. 2) and (2 in Fig. 3).

11. Open Valve (Item 1 - Fig 2) and admit a few pounds of air pressure into the Sprinkler System. Close Valve (Item 1 - Fig 2).
 12. Open separately Drain Valves (see Instruction No. 3) to force any water from low points of the system. Close these Valves when dry air appears and replace Plugs in Valve Outlets.
 13. Open Valve (Item 1 - Fig 2) and admit sufficient air into the sprinkler system to hold the Dry Pipe Valve closed against the water supply pressure in accordance with Water-Air Pressure Table II. The level of air pressure is adjusted by removing the cap nut on the top of the Relief Valve (Item 7 - Fig 2), and turning the now exposed slotted adjusting screw clockwise to increase pressure or counterclockwise to reduce it. Replace the cap nut and close Valve (Item 1 - Fig 2) after the correct air pressure setting has been made in accordance with NFPA 13, 3-2.6.4. Observe if water leaks through Ball Drip Valve (Item 17 - Fig 2) into Drip Cup (Item 18 - Fig 2). If no leak occurs, air seat is tightly sealed.
- Note:** When an Automatic Air Pressure Maintenance Device is used, Valve (1) should be left open. See Bulletin 254 for information on this device.
14. Open slightly Valve controlling water supply to Dry Pipe Valve closing Main Drain Valve (Item 3 - Fig 2) when water flows. Observe if water leaks through Ball Drip Valve (Item 17 - Fig 2) into Drip Cup (Item 18 - Fig 2). If no leak occurs, Air and Water Seats are tight. Open slowly but fully Valve controlling water supply to Dry Pipe Valve, and seal in this position.

Tests

To test the operation of the Dry Pipe Valve and its alarm equipment, open the 1" inspectors end line test connection which should cause the mechanical and electric alarms to sound.

This test connection is usually located on the end or top line of the system and is equivalent to the operation of one sprinkler. The main control valve must be completely open to allow sufficient flow for the clapper to latch open. Following this test the system must be drained and the Dry Pipe Valve reset.

To test the operation of the alarm equipment only, without operating the Dry Pipe Valve, open Valve (Item 4B - Fig 2), Fig. B. Should the Mechanical sprinkler alarm fail to operate, inspect Valve (Item 9 - Fig 2) for complete opening and the 3/4" Model B Strainer for clogging.

Parts Removal

Refer to Fig. 4.

To remove the Clapper Assembly (5) and seat (6), proceed as follows:

1. Clapper Assembly: With the Cover (3) off, remove the 3/8" Pipe Plug (11) from body. The Hinge Pin can then be slipped out of its bushings.

The Clapper can then be lifted through the cover opening.

Note: If replacement of the rubber facing is required, do not over tighten clamping ring bolts. Tighten only to 30 lbs. - in. If a torque wrench is not available, tighten bolts finger tight, and then an additional 1/8 of a turn only.

2. Seat: With the Clapper removed, the Seat (6) can be easily unscrewed from the body with the use of the Reliable Model D Dry Pipe Valve Seat Wrench (P/N 6881340000 for the 2 1/2" size).

Be careful not to damage the Seat. It is suggested that the seal surfaces be covered with masking tape prior to this operation.

Prior to replacing the Seat, the seal surfaces should be cleaned. The threads on the body and the Seat should be cleaned and lubricated and new lubricated "O" rings (7) and (8) should be used.

| Item No. | Part No. | Description | No. Req'd |
|----------|----------|----------------------------|-----------|
| 1 | 91006200 | Body - 2 1/2 NPT ANSI B2.1 | 1 |
| | 91006201 | Body - 65mm BS21 | |
| | 91006203 | Body - U.S. Grooved | |
| 2 | 91106202 | Cover - Bolts | 9 |
| 3 | 92106200 | Cover | 1 |
| 4 | 93706202 | Cover Gasket | 1 |
| 5 | 71010223 | Clapper Assembly | 1 |
| 6 | 96006200 | Seat | 1 |
| 7 | 95436123 | Seat "O" Ring | 1 |
| 8 | 95436224 | Body "O" Ring | 1 |
| 9 | 98604403 | Pipe Plug - 1/4" | 1 |
| 10 | 95006126 | Hinge Pin | 1 |
| 11 | 95206123 | Pipe Plug - 3/8" | 1 |
| 12 | 93406202 | Clapper Rubber Facing | 1 |
| 13 | 95306202 | Clamping Ring | 1 |
| 14 | 95606202 | Clamping Ring Screw | 5 |

Engineering Specification

2 1/2" (65 mm)

Model A Dry Pipe Valve

Dry pipe valve shall be a [2 1/2" (65mm)] [cULus Listed] [FM Approved] differential type valve with single hinge pin and latch design with galvanized [basic trim - basic trim shall include a 1/2" relief valve, a 3/4" check valve, and a 3/4" control valve on the air pressure line in accordance with NFPA 13] [priming chamber attachment trim] [fill line attachment trim]. Water to air seat area differential to be at least 6 to 1, capable of controlling air pressure ranging from 20 to 50 psi (1.4 to 3.4 bar). Dry pipe valve construction shall be cast iron. Dry pipe valve seat shall be of bronze construction with O-ring seals to prevent corrosion and leakage. Threaded-in, one piece air and water seat shall be removable for ease of maintenance. Clapper shall consist of ductile iron with sintered brass clapper bushings, and contain a one-piece clapper rubber facing. End connection styles to be [2 1/2" (65 mm) threaded inlet and outlet in accordance with ANSI B1.20.1][2 1/2" (65 mm) threaded inlet and outlet in accordance with ISO 7-1][2 1/2" (65 mm) grooved inlet and outlet in accordance with ANSI/AWWA C606]. Dry pipe valve shall have a rated working pressure of 175 psi (12.1 bar) and shall be factory hydrostatic tested at 350 psi (24.1 bar). The friction loss for the dry valve shall not exceed 10 feet (3.0 m) of equivalent length of Schedule 40 pipe. Dry pipe valve to be Reliable Model A [2 1/2" (65 mm)] (Bulletin 353).

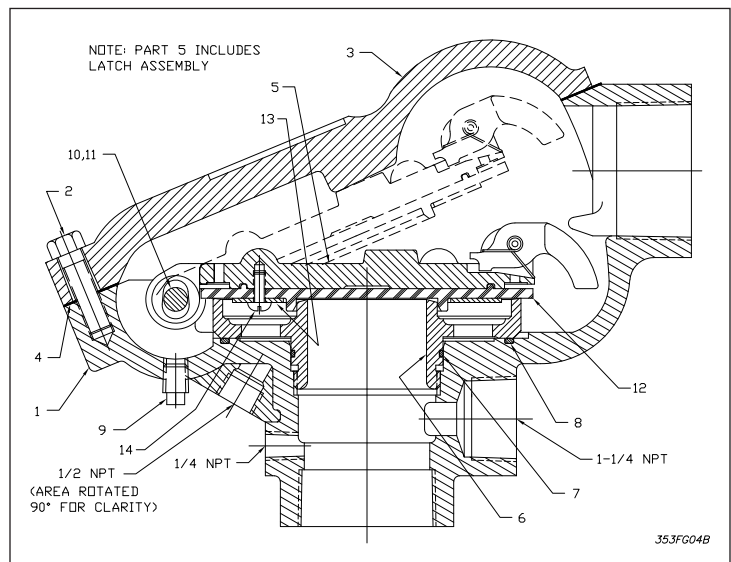

Fig. 4

Note: Contact the installing contractor or Reliable if any difficulties are experienced. Should replacement parts be needed, use only Reliable Made Parts. When ordering specify part number, name, size, model and serial number of the unit.

The equipment presented in this bulletin is to be installed in accordance with the latest published Standards of the National Fire Protection Association, Factory Mutual Research Corporation, or other similar organizations and also with the provisions of governmental codes or ordinances whenever applicable. Products manufactured and distributed by Reliable have been protecting life and property for over 90 years.

Manufactured by

Reliable®

The Reliable Automatic Sprinkler Co., Inc.

(800) 431-1588

(800) 848-6051

(914) 829-2042

www.reliablesprinkler.com

Sales Offices

Sales Fax

Corporate Offices

Internet Address



Recycled Paper

Revision lines indicate updated or new data.

EG. Printed in U.S.A. 06/20

P/N 9999970047