



Model F1-FTR Fixed Temperature Release Pilot Line Detector

Features

- Fixed temperature heat responsive detector
- Die cast brass frame
- Fast response thermal element

Product Description

The Reliable Model F1-FTR Fixed Temperature Release Pilot Line Detector (PLD) is designed to be used on wet or dry pilot line release systems to trigger the operation of deluge and preaction fire protection systems. It is identified as a fixed temperature release pilot line detector to differentiate it from a sprinkler.

The FTR incorporates a very sensitive 2.5 mm glass bulb in a Model F1 Sprinkler frame. During fire conditions, the heat sensitive liquid in the bulb expands until the bulb shatters, releasing the cap and spring assembly. This releases the hydraulic or pneumatic pressure holding the deluge valve closed, causing the valve to open and deliver water to the fire protection system discharge devices.

Application

The Reliable Model F1-FTR Pilot Line Detector is intended for use on wet or dry pilot lines to act as a non-electrical detection system to release deluge and preaction fire protection systems. Design and installation of the detection system shall be in accordance with the requirements of NFPA 11, 13, 15, and/or other national standards as well as all authorities having jurisdiction.

Spacing and location of detectors shall be in accordance with the minimum requirements of NFPA and approved by the authority having jurisdiction with consideration given (but not necessarily limited) to height above the protected area, obstructions, slope of roof or ceiling, and effects of air movement.

Important! Reliable fire sprinklers must be handled, stored, and installed in accordance with the guidelines in Caution Sheet 310 and this bulletin. Failure to follow these instructions may result in unintended operation or nonoperation of the fire protection system.



Model F1-FTR

Note: Not all versions of product are shown.

Under smooth flat horizontal ceilings, in no case shall the spacing of detectors exceed 50 ft x 50 ft (15 m x 15 m) for 135°F (57°C) detectors and 40 ft x 40 ft (12 m x 12 m) for 155°F (68°C), 175°F (79°C), and 200°F (93°C) detectors.

Note that the temperature rating of the F1-FTR Pilot Line Detector must be lower than that of the fire sprinklers in the protected space. Careful consideration should be given to the effects of direct sunlight and proximate heat sources that could lead to unintended operation of the system.

Model F1-FTR Fixed Temperature Release Pilot Line Detector Summary

Table A

Style	Orientation	Temperature Ratings °F (°C)	Max. Working Pressure psi (bar)	Listings & Approvals
F1-FTR	Wet Pilot Line: Not Restricted	135 (57), 155 (68), 175 (79), 200 (93)	175 (12.1)	cULus
	Dry Pilot Line: Upright Only			

Model F1-FTR Fixed Temperature Release Pilot Line Detector

Technical Specifications

Style: Fixed-frame
Threads: 1/2" NPT or ISO 7-1R1/2
Orifice: Nominal 1/2" (15mm)
Max. Working Pressure: 175 psi (12.1 bar)

Material Specifications

Thermal Sensor: 2.5mm Glass Bulb
Sprinkler Frame: Brass Alloy
Button/Cup: Brass Alloy
Sealing Assembly: Brass with PTFE
Load Screw: Bronze
Deflector: Bronze Alloy

Finishes

Brass
 Chrome
 White Polyester⁽¹⁾
 Custom Color Polyester⁽¹⁾

Sensitivity

Fast Response

Temperature Ratings

135°F (57°C)
 155°F (68°C)
 175°F (79°C)
 200°F (93°C)

Listings and Approvals

cULus⁽²⁾



Notes:

1. Will provide additional protection against the effects of corrosion
2. Listed under UL EX2634 - Accessories for Special Systems

Model F1-FTR Components and Dimensions

Figure 1

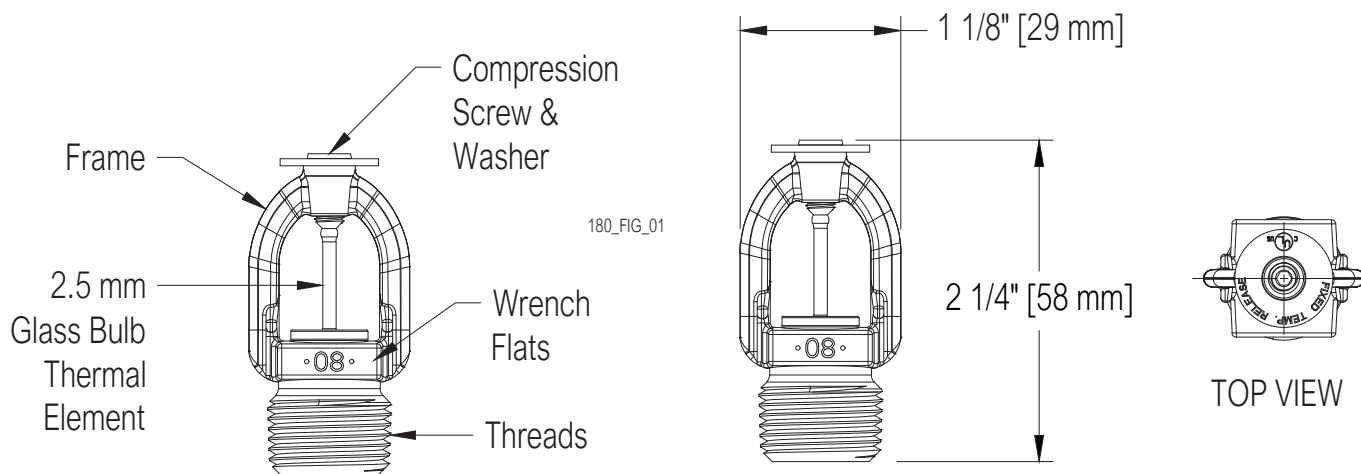

Installation

Reliable Model F1-FTR pilot line detectors must be installed in accordance with NFPA 13 and the requirements of all applicable authorities having jurisdiction. Before installing, confirm that the F1-FTR detector has the appropriate temperature rating which must be lower than the temperature rating of the automatic nozzles or fire sprinklers on the system.

Model F1-FTR detectors must be installed with the Reliable installation wrench identified in this bulletin. Any other wrench may damage the detector. The Model W2 wrench has two sets of jaws. Use the smallest set of jaws that fit on the wrench flat of the detector. A leak tight joint can be obtained with a torque of 8 to 18 lb-ft (11 to 24 N.m). Do not tighten detectors over the maximum recommended installation torque. Exceeding the maximum recommended installation torque may cause leakage or impairment of the detector.

The Model F1-FTR detector may be oriented in any position on wet pilot lines and dry pilot lines installed in spaces maintained at or above 40°F (4°C), however, when used on dry pilot lines in areas subject to freezing they shall be installed in the upright position only. Note that there are height and distance limitations when using the Model F1-FTR on wet pilot lines (further information may be found on deluge valve technical bulletins.) Model F1-FTR pilot line detectors that may be subject to mechanical damage can be protected by installing the appropriate Reliable sprinkler guard for an F1 fire sprinkler (see Bulletin 208).

Model F1-FTR detectors must be handled carefully and stored in a cool, dry location in the original container. Never install an F1-FTR detector that has been dropped or damaged in anyway. Do not install the F1-FTR detector if the bulb is cracked or is missing fluid in the bulb, and never install an F1-FTR detector that has been exposed to temperatures in excess of the allowed ambient temperature. Model F1-FTR detectors that are not in their original condition at the time of installation shall not be used.

Model W2 Wrench

Figure 2



Maintenance

Reliable Model F1-FTR pilot line detectors should be inspected and the fire protection system maintained in accordance with NFPA 25 as well as the requirements of any authorities having jurisdiction. Any system maintenance or testing that involves placing the detection system out of service may eliminate the fire protection that is provided by the fire protection system.

Prior to installation, detectors should remain in the original cartons and packaging until used. This will minimize the potential for damage to detectors that could cause improper operation or non-operation. Do not clean detectors with soap and water, ammonia liquid, or any other cleaning fluids. Remove dust by gentle vacuuming or with compressed air without touching the detector. Replace any detector which has been painted (other than factory applied).

A stock of spare detectors should be maintained to allow quick replacement of damaged detectors, operated detectors, or detectors exposed to high temperatures during a fire event. Failure to properly maintain and/or replace pilot line detectors may result in inadvertent operation or non-operation during a fire event.

Guarantee

For the Reliable Automatic Sprinkler Co., Inc. guarantee, terms, and conditions, visit www.reliablesprinkler.com.

Ordering Information

Specify:

Sprinkler

- Model F1-FTR Sprinkler

Temperature Rating

- 135°F (57°C)
- 155°F (68°C)
- 175°F (79°C)
- 200°F (93°C)

End Connection

- 1/2 NPT
- ISO7-1R1/2 (BSPT)

Finish

- Brass
- Chrome
- White Polyester
- Custom Color Polyester

Wrench

- Model W2