

Reliable®

Model F3-80 Series Standard-Response Dry Sprinkler

K-factor 8.0 (115 metric)

Features

- Various trim options available
- Sprinklers and trim available in a wide variety of standard and special application finishes
- Standard 1" NPT or ISO7-R1 inlet fitting
- Listed corrosion resistant combinations of sprinkler and trim available

Product Description

Model F3-80 dry sprinklers are standard-response, standard coverage sprinklers with a nominal K-factor of 8.0 (115 metric). Available in pendent and horizontal sidewall configurations, Model F3-80 dry sprinklers utilize a 5mm glass bulb ordinary, intermediate, or high temperature classification operating element.

Model F3-80 dry sprinklers are intended for installation on wet pipe, dry pipe, or preaction systems in accordance with NFPA 13 or other applicable installation standards.

Model F3-80 dry sprinklers are available in a variety of trim options and finish combinations as shown on the following pages. The Reliable escutcheons and cover plates shown are the only escutcheons and cover plates listed for use with the sprinkler. The use of any other escutcheon or cover plate will void all guarantees, warranty, listing, and approvals.

Table A provides a basic summary of Model F3-80 dry sprinklers. Additional technical information is provided on the following individual sprinkler pages.

Important! Reliable fire sprinklers must be handled, stored, and installed in accordance with the guidelines in Caution Sheet 310 and this bulletin. Failure to follow these instructions may result in unintended operation or nonoperation of the fire protection system.



(Note: Not all versions of sprinkler shown, please see pages 2-10)

Model F3-80 Dry Sprinkler Summary

Table A

Sprinkler Model	K-Factor gpm/psi ^{1/2} (lpm/bar ^{1/2})	Approvals*	Max. Working Pressure psi (bar)	Sprinkler Identification Number (SIN)
F3-80 Dry Pendent	8.0 (115)	cULus, CE	175 (12.0)	RA6012
F3-80 Dry Horizontal Sidewall	8.0 (115)	cULus, CE	175 (12.0)	RA6032

*Note: Approvals may not apply to all trim, inlet thread, temperature, and/or finish combinations. See pages 2-10 for additional technical information.

Model F3-80 Dry Pendant: Standard Escutcheon - SIN RA6012

Table B

"A" Dimension in (mm)	Temperature Classification	Temperature Rating °F (°C)	Glass Bulb Color	Approvals	Sprinkler Guard
2" to 36" (50mm to 900mm) in 1/4" (6mm) increments	Ordinary	155°F (68°C)	Red	cULus, CE	N/A
	Intermediate	175°F (79°C)	Yellow		
		200°F (93°C)	Green		
	High	286°F (141°C)	Blue		



Model F3-80 Dry Pendant Sprinkler: Standard Escutcheon

Figure 1

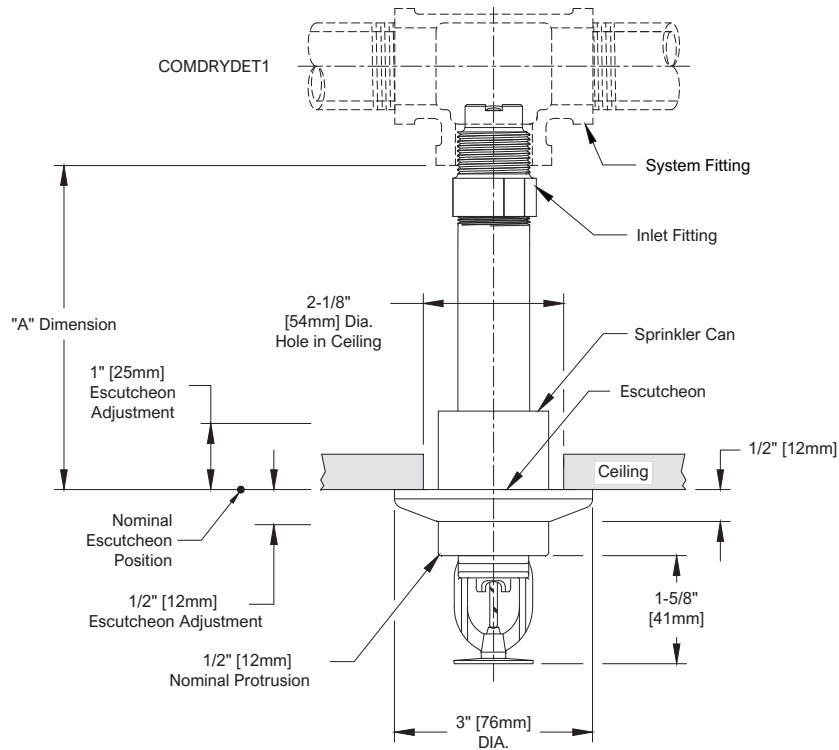

Note: The sprinkler can protrudes 1/2" (12mm) when escutcheon is in nominal position. Escutcheon adjustment provides -1/2" (12mm) to +1" (25mm) "A" dimension adjustment range.

Finish Combinations: Standard Escutcheon	
Sprinkler	Escutcheon ⁽³⁾⁽⁴⁾
Bronze	Polished Stainless
Bronze	Laquered Brass
Chrome	Polished Stainless
White Polyester ⁽¹⁾	White Polyester
Black Polyester ⁽¹⁾	Black Polyester
Custom Color Polyester ⁽¹⁾	Custom Color Polyester
Electroless Nickel PTFE ⁽¹⁾	Polished Stainless
Wax ⁽¹⁾⁽²⁾	Polished Stainless
Lead ⁽¹⁾	Polished Stainless
Wax over Lead ⁽¹⁾⁽²⁾	Polished Stainless

Notes:

1. UL Listed as Corrosion Resistant.
2. Clear wax used on ordinary temperature rated sprinklers; brown wax used on intermediate temperature rated sprinklers. Brown wax may be used on high temperature rated sprinklers where the ambient temperature does not exceed 150°F (66°C).
3. Escutcheons do not carry corrosion resistant listings.
4. Base material is 316 stainless steel unless noted.

Model F3-80 Dry Pendent: HB Escutcheon - SIN RA6012

Table C

"A" Dimension in (mm)	Temperature Classification	Temperature Rating F (C)	Glass Bulb Color	Approvals	Sprinkler Guard
3½" to 36" (90mm to 900mm) in ¼" (6mm) increments	Ordinary	155°F (68°C)	Red	cULus, CE	N/A
	Intermediate	175°F (79°C)	Yellow		
		200°F (93°C)	Green		
	High	286°F (141°C)	Blue		



Model F3-80 Dry Pendent Sprinkler: HB Escutcheon

Figure 2

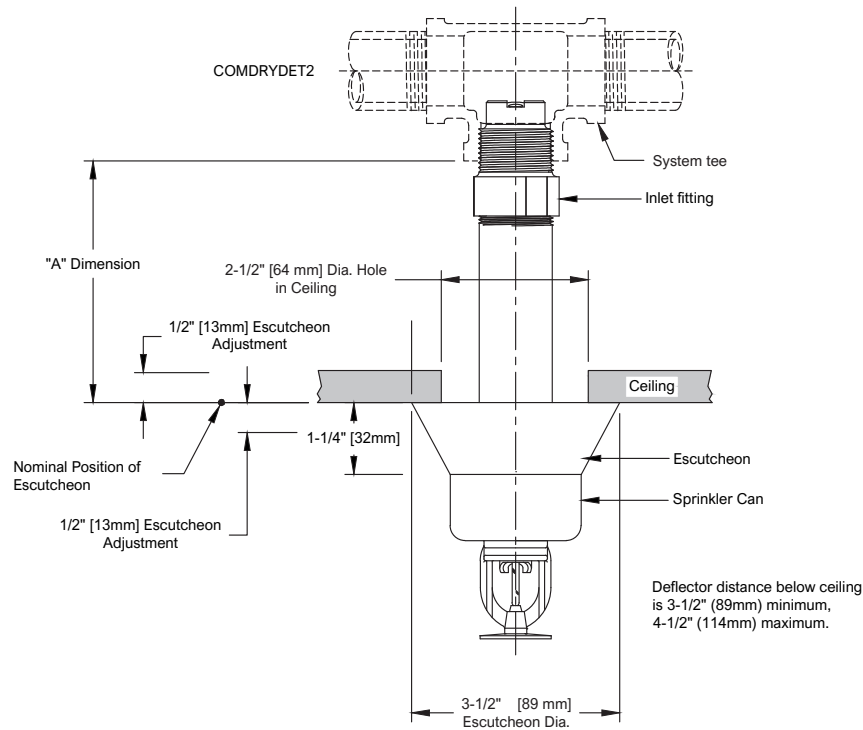

Note: The sprinkler can protrudes 1¼" when escutcheon is in nominal position. Escutcheon adjustment provides -½" (-12.7mm) to +½" (+12.7mm) "A" dimension adjustment range.

Finish Combinations: HB Escutcheon	
Sprinkler	Escutcheon ⁽³⁾⁽⁴⁾
Bronze	Chrome
Chrome	Chrome
White Polyester ⁽¹⁾	White Polyester
Black Polyester ⁽¹⁾	Black Polyester
Custom Color Polyester ⁽¹⁾	Custom Color Polyester
Electroless Nickel PTFE ⁽¹⁾	Stainless Steel
Wax ⁽¹⁾⁽²⁾	Chrome
Lead ⁽¹⁾	Stainless Steel
Wax over Lead ⁽¹⁾⁽²⁾	Stainless Steel

Notes:

1. UL Listed as Corrosion Resistant.
2. Clear wax used on ordinary temperature rated sprinklers; brown wax used on intermediate temperature rated sprinklers. Brown wax may be used on high temperature rated sprinklers where the ambient temperature does not exceed 150°F (66°C).
3. Escutcheons do not carry corrosion resistant listings.
4. Base material is cold rolled steel unless noted.

Model F3-80 Dry Pendent: FP Escutcheon - SIN RA6012

Table D

"A" Dimension in (mm)	Temperature Classification	Temperature Rating °F (°C)	Glass Bulb Color	Approvals	Sprinkler Guard
3 1/2" to 36" (90mm to 900mm) in 1/4" (6mm) increments	Ordinary	155°F (68°C)	Red	cULus, CE	N/A
	Intermediate	175°F (79°C)	Yellow		
		200°F (93°C)	Green		
	High	286°F (141°C)	Blue		



Model F3-80 Dry Pendent Sprinkler: FP Escutcheon

Figure 3

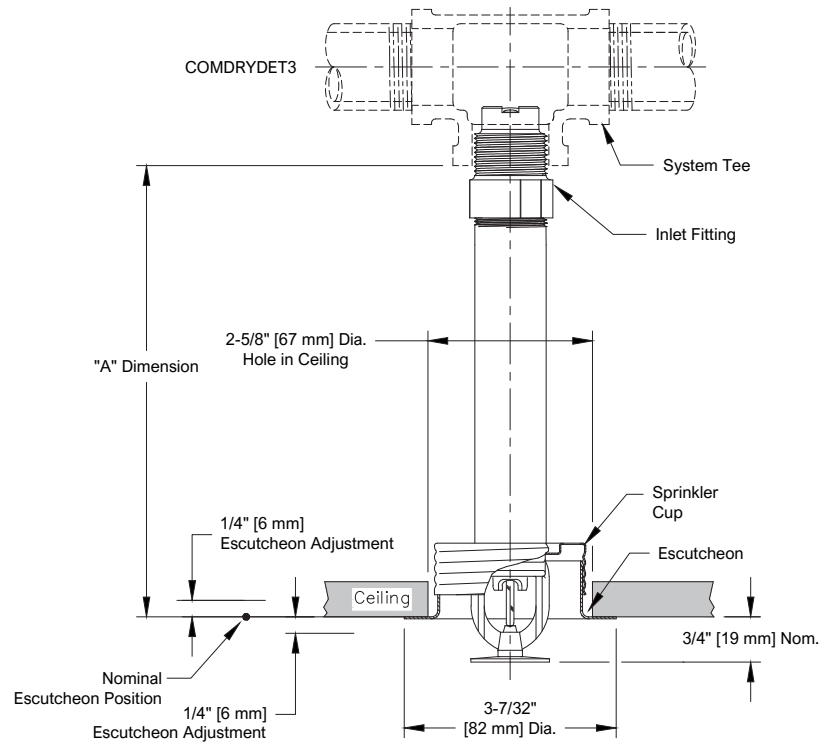

Finish Combinations: FP Recessed	
Sprinkler ⁽¹⁾	Escutcheon ⁽³⁾⁽⁴⁾
Bronze	Brass
Chrome	Chrome
White Polyester ⁽²⁾	White Polyester
Black Polyester ⁽²⁾	Black Polyester
Custom Color Polyester ⁽²⁾	Custom Color Polyester
Electroless Nickel PTFE ⁽²⁾	Stainless Steel

- Notes:**
1. Cup for FP Recessed is unfinished galvanized steel except electroless nickel PTFE sprinklers which are provided with a stainless steel cup
 2. UL Listed as Corrosion Resistant.
 3. Escutcheons do not carry corrosion resistant listings.
 4. Base material is cold rolled steel unless noted.

Note: Do not install the Model F3-80 Dry Pendent sprinkler with the Model FP escutcheon in ceilings which have positive pressure in the space above.

Model F3-80 Dry Pendant: CCP Cover Plate - SIN RA6012

Table E

"A" Dimension in (mm)	Temperature Classification	Temperature Rating F (C)	Glass Bulb Color	Approvals	Sprinkler Guard
3 1/2" to 36" (90mm to 900mm) in 1/4" (6mm) increments	Ordinary	155°F (68°C)	Red	cULus, CE	N/A
	Intermediate	175°F (79°C)	Yellow		
		200°F (93°C)	Green		
	High (See Caution)	286°F (141°C)	Blue		



Model F3-80 Dry Pendant Sprinkler: CCP Cover Plate

Figure 4

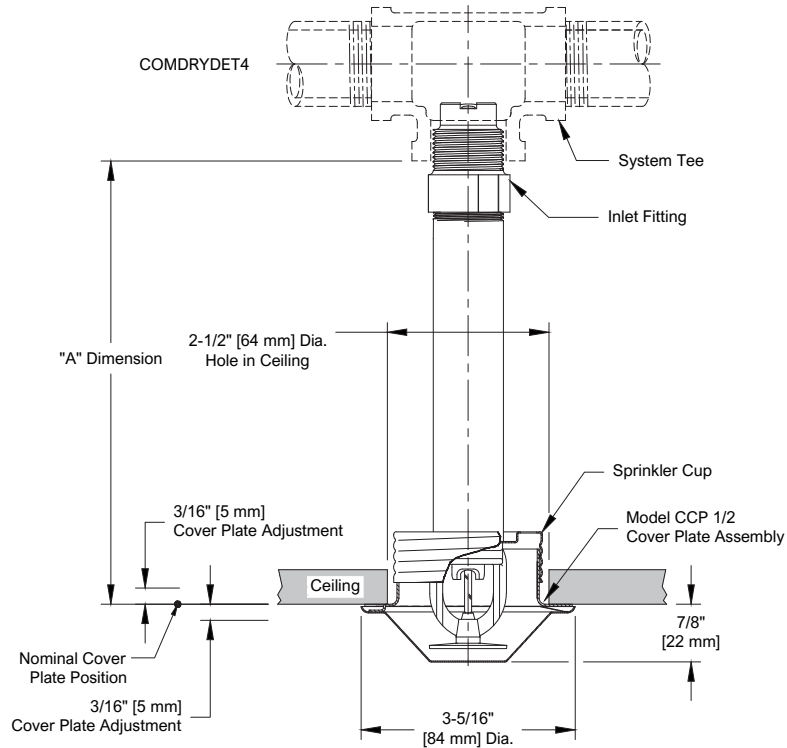

Finish Combinations: CCP Concealed	
Sprinkler ⁽¹⁾	Cover Plate ⁽²⁾
Bronze	White Polyester
	Chrome Bright
	Satin Chrome
	Bright Brass
	Unfinished Bronze
	Black Plate
	Custom Color

Notes:

1. Cup for CCP Concealed is unfinished galvanized steel.
2. Cover plates do not carry corrosion resistant listings.

Caution: High temperature CCP sprinklers are provided with a 165°F (74°C) rated cover plate that is suitable for use where the ceiling temperature will not exceed 150°F (66°C). Do not use CCP style sprinklers where the ceiling temperature exceeds 150°F (66°C).

Note: Do not install the Model F3-80 Dry Pendant sprinkler with the Model CCP cover plate in ceilings which have positive pressure in the space above.

Model F3-80 Dry Pendent: No Escutcheon - SIN R6012

Table F

Order Dimension in (mm)	Temperature Classification	Temperature Rating °F (°C)	Glass Bulb Color	Approvals	Sprinkler Guard
5" to 36" (125mm to 900mm) in 1/4" (6mm) increments	Ordinary	155°F (68°C)	Red	cULus, CE	N/A
	Intermediate	175°F (79°C)	Yellow		
		200°F (93°C)	Green		
	High	286°F (141°C)	Blue		



Model F3-80 Dry Pendent Sprinkler: No Escutcheon

Figure 5

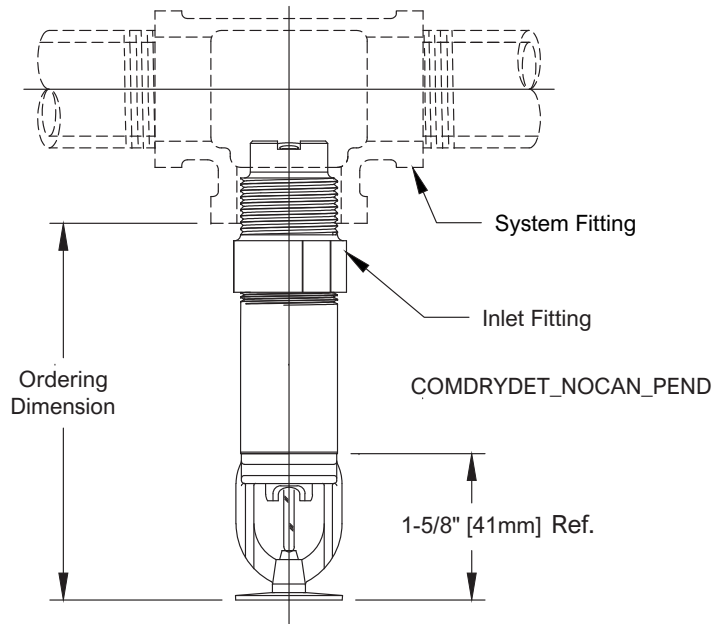

Note: Customer is responsible for determining the correct deflector distance from the ceiling or structure above.

Available Finishes
No Escutcheon Dry Pendent Sprinkler
Bronze
Chrome
White Polyester ⁽¹⁾
Black Polyester ⁽¹⁾
Custom Color Polyester ⁽¹⁾
Wax ⁽¹⁾⁽²⁾
Lead ⁽¹⁾
Wax Over Lead ⁽¹⁾⁽²⁾
Electroless Nickel PTFE ⁽¹⁾

Notes:

1. UL Listed as Corrosion Resistant.
2. Clear wax used on ordinary temperature rated sprinklers; brown wax used on intermediate temperature rated sprinklers. Brown wax may be used on high temperature rated sprinklers where the ambient temperature does not exceed 150°F (66°C).

Model F3-80 Dry Horizontal Sidewall: Standard Escutcheon - SIN RA6032

Table G

"A" Dimension in (mm)	Temperature Classification	Temperature Rating °F (°C)	Glass Bulb Color	Approvals (Light Hazard Only)	Sprinkler Guard
2" to 36" (50mm to 900mm) in 1/4" (6mm) increments	Ordinary	155°F (68°C)	Red	cULus, CE	N/A
	Intermediate	175°F (79°C)	Yellow		
		200°F (93°C)	Green		
	High	286°F (141°C)	Blue		



Model F3-80 Dry Horizontal Sidewall: Standard Escutcheon

Figure 5

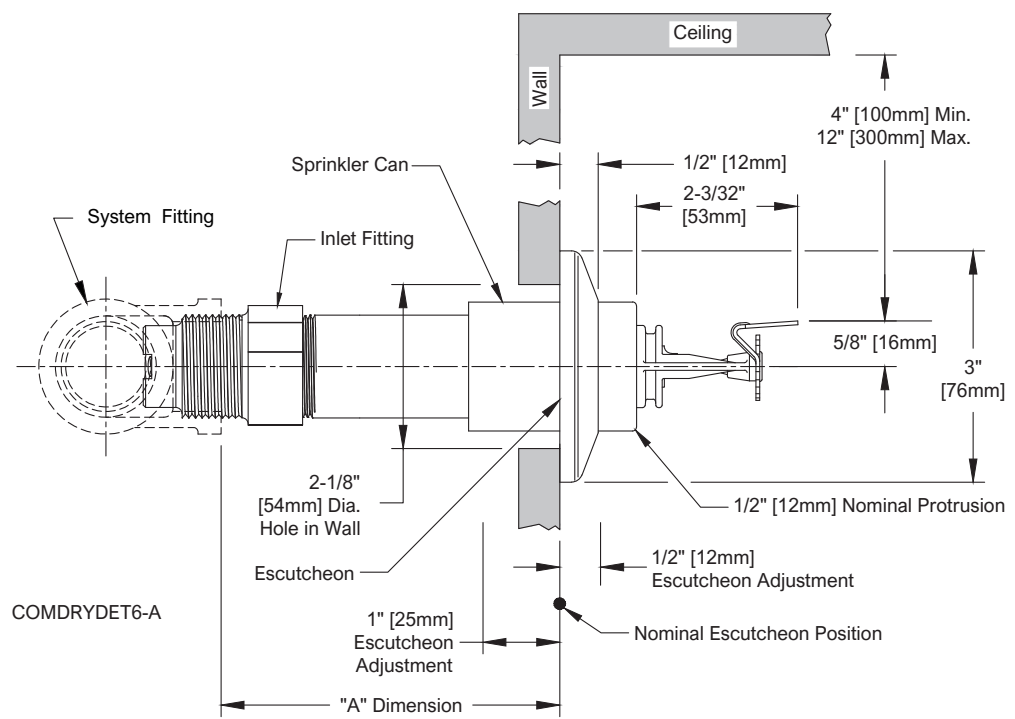

Finish Combinations: Standard Escutcheon	
Sprinkler	Escutcheon ⁽³⁾⁽⁴⁾
Bronze	Polished Stainless
Bronze	Laquered Brass
Chrome	Polished Stainless
White Polyester ⁽¹⁾	White Polyester
Black Polyester ⁽¹⁾	Black Polyester
Custom Color Polyester ⁽¹⁾	Custom Color Polyester
Electroless Nickel PTFE ⁽¹⁾	Polished Stainless
Wax ⁽¹⁾⁽²⁾	Polished Stainless
Lead ⁽¹⁾	Polished Stainless
Wax over Lead ⁽¹⁾⁽²⁾	Polished Stainless

- Notes:**
1. UL Listed as Corrosion Resistant.
 2. Clear wax used on ordinary temperature rated sprinklers; brown wax used on intermediate temperature rated sprinklers. Brown wax may be used on high temperature rated sprinklers where the ambient temperature does not exceed 150°F (66°C).
 3. Escutcheons do not carry corrosion resistant listings.
 4. Base material is 316 stainless steel unless noted.

Note: The sprinkler can protrude 1/2" when escutcheon is in nominal position. Escutcheon adjustment provides -1/2" (-12mm) to +1" (25mm) "A" dimension adjustment range.

Model F3-80 Dry Horizontal Sidewall: HB Escutcheon - SIN RA6032

Table H

"A" Dimension in (mm)	Temperature Classification	Temperature Rating °F (°C)	Glass Bulb Color	Approvals (Light Hazard Only)	Sprinkler Guard
3 1/2" to 36" (90mm to 900mm) in 1/4" (6mm) increments	Ordinary	155°F (68°C)	Red	cULus, CE	N/A
	Intermediate	175°F (79°C)	Yellow		
		200°F (93°C)	Green		
	High	286°F (141°C)	Blue		



Model F3-80 Dry Horizontal Sidewall: HB Escutcheon

Figure 6

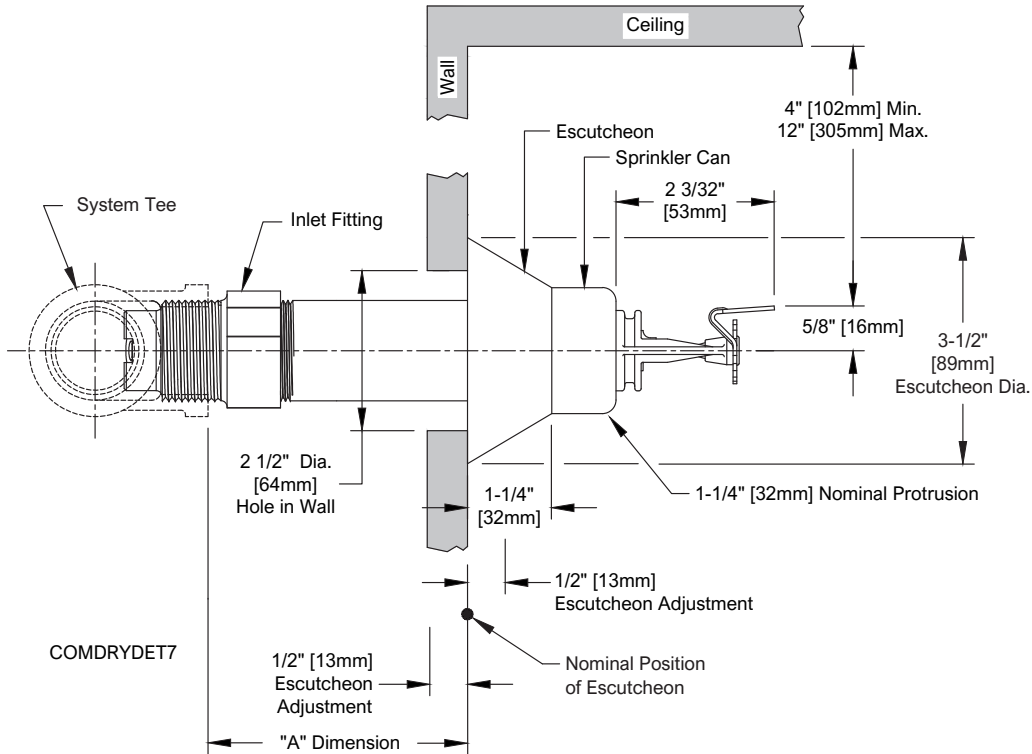

Finish Combinations: HB Escutcheon	
Sprinkler	Escutcheon ⁽³⁾⁽⁴⁾
Bronze	Chrome
Chrome	Chrome
White Polyester ⁽¹⁾	White Polyester
Black Polyester ⁽¹⁾	Black Polyester
Custom Color Polyester ⁽¹⁾	Custom Color Polyester
Electroless Nickel PTFE ⁽¹⁾	Stainless Steel
Wax ⁽¹⁾⁽²⁾	Chrome
Lead ⁽¹⁾	Stainless Steel
Wax over Lead ⁽¹⁾⁽²⁾	Stainless Steel

- Notes:**
1. UL Listed as Corrosion Resistant.
 2. Clear wax used on ordinary temperature rated sprinklers; brown wax used on intermediate temperature rated sprinklers. Brown wax may be used on high temperature rated sprinklers where the ambient temperature does not exceed 150°F (66°C).
 3. Escutcheons do not carry corrosion resistant listings.
 4. Base material is cold rolled steel unless noted.

Note: The sprinkler can protrudes 1/4" when escutcheon is in nominal position. Escutcheon adjustment provides -1/2" (-12.7mm) to +1/2" (+12.7mm) "A" dimension adjustment range.

Model F3-80 Dry Horizontal Sidewall: FP Escutcheon - SIN RA6032

Table J

"A" Dimension in (mm)	Temperature Classification	Temperature Rating °F (°C)	Glass Bulb Color	Approvals (Light Hazard Only)	Sprinkler Guard
3 1/2" to 48" (90mm to 900mm) in 1/4" (6mm) increments	Ordinary	155°F (68°C)	Red	cULus, CE	N/A
	Intermediate	175°F (79°C)	Yellow		
		200°F (93°C)	Green		
	High	286°F (141°C)	Blue		



Model F3-80 Dry Horizontal Sidewall: FP Escutcheon

Figure 8

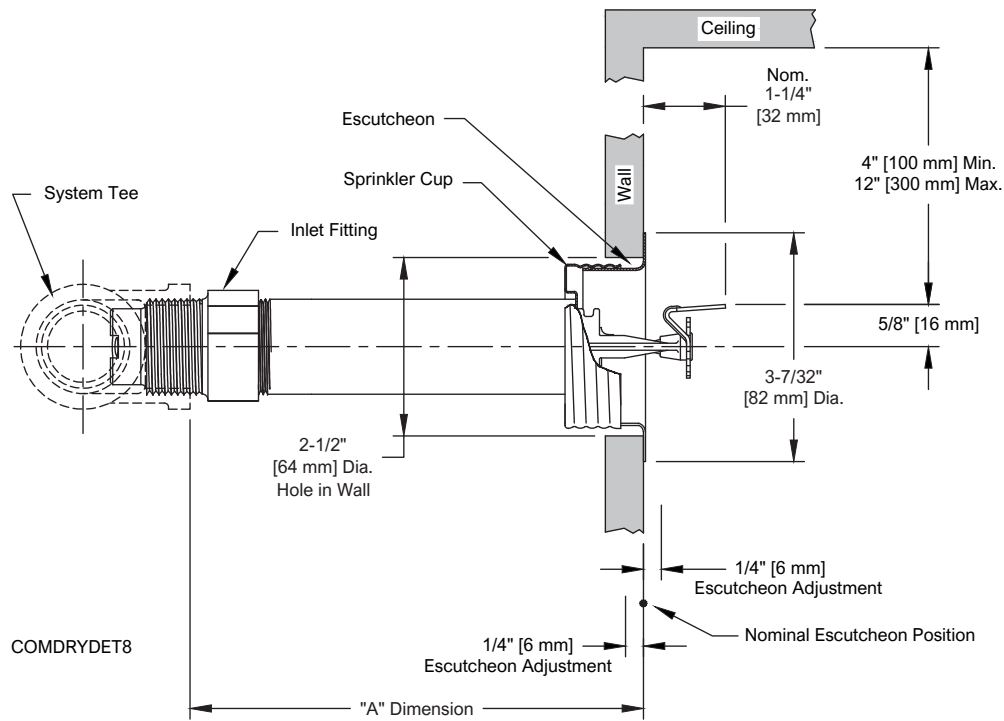

Finish Combinations: FP Recessed	
Sprinkler ⁽¹⁾	Escutcheon ⁽³⁾⁽⁴⁾
Bronze	Brass
Chrome	Chrome
White Polyester ⁽²⁾	White Polyester
Black Polyester ⁽²⁾	Black Polyester
Custom Color Polyester ⁽²⁾	Custom Color Polyester
Electroless Nickel PTFE ⁽²⁾	Stainless Steel

- Notes:**
1. Cup for FP Recessed is unfinished galvanized steel except electroless nickel PTFE sprinklers which are provided with a stainless steel cup
 2. UL Listed as Corrosion Resistant.
 3. Escutcheons do not carry corrosion resistant listings.
 4. Base material is cold rolled steel unless noted.

Note: Do not install the Model F3-80 Dry Horizontal Sidewall sprinkler with the Model FP escutcheon in walls which are positively pressurized with respect to the protected space.

Model F3-80 Dry Horizontal Sidewall: No Escutcheon - SIN RA6032

Table I

Order Dimension in (mm)	Temperature Classification	Temperature Rating °F (°C)	Glass Bulb Color	Approvals (Light Hazard Only)	Sprinkler Guard
5" to 36" (125mm to 900mm) in 1/4" (6mm) increments	Ordinary	155°F (68°C)	Red	cULus, CE	N/A
	Intermediate	175°F (79°C)	Yellow		
		200°F (93°C)	Green		
	High	286°F (141°C)	Blue		



Model F3-80 Dry Horizontal Sidewall: No Escutcheon

Figure 7

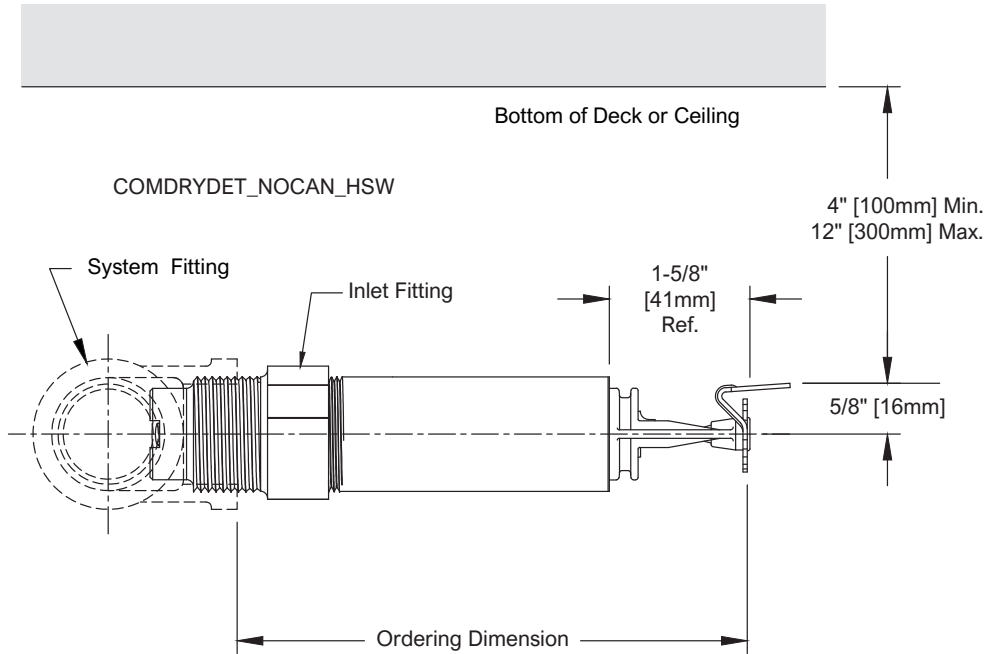

Note: Customer is responsible for determining the correct distance from the wall to the sprinkler deflector.

Available Finishes
No Escutcheon Dry Pendent Sprinkler
Bronze
Chrome
White Polyester ⁽¹⁾
Black Polyester ⁽¹⁾
Custom Color Polyester ⁽¹⁾
Wax ⁽¹⁾⁽²⁾
Lead ⁽¹⁾
Wax Over Lead ⁽¹⁾⁽²⁾
Electroless Nickel PTFE ⁽¹⁾

- Notes:**
1. UL Listed as Corrosion Resistant.
 2. Clear wax used on ordinary temperature rated sprinklers; brown wax used on intermediate temperature rated sprinklers. Brown wax may be used on high temperature rated sprinklers where the ambient temperature does not exceed 150°F (66°C).

Installation (General)

Dry sprinklers connected to wet pipe systems must be installed as indicated in Figure 13 and as required by NFPA 13 with the Exposed Minimum Barrel Length located in a heated area.

Reliable Model F3-80 dry sidewall sprinklers may be installed in ductile or malleable cast iron threaded tees, or CPVC tees and adapters upon verification that the sprinkler inlet fitting does not interfere with the interior of the fitting (see Figure 11).

DO NOT install Reliable Model F3-80 dry sidewall sprinklers into elbows or couplings, welded outlets, mechanical tees, or gasket sealed CPVC fittings.

See Figure 12 for acceptable and unacceptable installation practices.

F3-80 with Standard Escutcheon

Cut a 2-1/8" (54mm) diameter hole in the wall as shown in Fig. 2. Apply a PTFE based sealant to the sprinkler threads before installing into the fitting. Use the Model F3R installation wrench (see Fig. 5) on the square boss to tighten the sprinkler until it is secured in the sprinkler fitting. Installation is completed by removing the orange glass bulb protector and sliding the escutcheon over the finished sleeve until tight to the finished surface.

F3-80 with HB Escutcheon

Cut a 2-1/2" (64mm) diameter hole in the wall as shown in Fig. 3. Apply a PTFE based sealant to the sprinkler threads before installing into the fitting. Use the Model F3R installation wrench (see Fig. 5) on the square boss to tighten the sprinkler until it is secured in the sprinkler fitting. Installation is completed by removing the orange glass bulb protector and sliding the skirt over the finished sleeve until tight to the finished surface.

F3-80 with FP Recessed Escutcheon

Cut a 2-5/8" (67mm) diameter hole in the wall as shown in Fig. 4. Apply a PTFE based sealant to the sprinkler threads before installing into the fitting. Use the Model F3R installation wrench (see Fig. 8) on the square boss to tighten the sprinkler until it is secured in the sprinkler fitting. Installation is completed by removing the orange glass bulb protector and pushing (or threading) the FP escutcheon into the threaded cup. Final adjustment is made by turning the FP escutcheon clockwise until the flange makes full contact with the wall surface.

F3-80 CCP Concealed Cover Plate

Cut a 2-5/8" (67mm) diameter hole in the wall as shown in Fig. 5. Apply a PTFE based sealant to the sprinkler threads before installing into the fitting. Use the Model F3R installation wrench (see Fig. 8) on the square boss to tighten the sprinkler until it is secured in the sprinkler fitting. Installation is completed by removing the orange glass bulb protector and pushing (or threading) the SWC cover plate into the threaded cup. Final adjustment is made by turning the cover plate clockwise until the cover plate flange makes full contact with the finished surface.

Note:

1. The Model XLO2 installation wrench for recessed and concealed installations has an open side to accommodate the sprinkler deflector and can only be inserted in one way (see Figure 9). Care must be taken not to damage the deflector during installation.
2. Do not over-tighten sprinklers into fittings. It is recommended that Reliable dry sprinklers be installed using the wrench referenced in this bulletin. A pipe wrench may also be used to install dry sprinklers provided that it only engages the outer tube (steel pipe) of the assembly. Note that a pipe wrench will impart a large amount of torque into the final assembly. This torque will need to be matched or exceeded to remove the sprinkler at a later date. A leak free joint can normally be obtained by installing the sprinkler to a minimum torque of 22 ft-lb (30 N·m) after applying an appropriate thread sealant.
3. Glass bulb sprinklers have orange bulb protectors to minimize bulb damage during shipping, handling, and installation. Reliable installation wrenches are designed to install sprinklers while bulb protectors are in place. REMOVE THE PROTECTORS AT THE TIME THE SPRINKLER SYSTEM IS PLACED INTO SERVICE. Removal of the protectors before this time may leave the glass bulb vulnerable to damage. Remove protectors by undoing the clasp by hand. DO NOT USE TOOLS TO REMOVE THE PROTECTORS.
4. Do not remove the wax fillet in the gap between the cup that supports the bulb and the wrenching boss.

XLO2 Installation Procedure

Figure 9

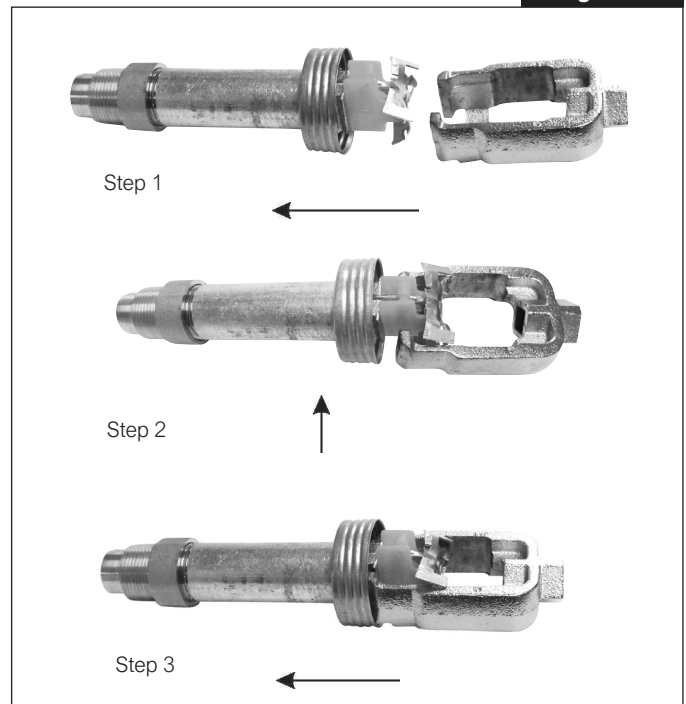

MINIMUM EXPOSED BARREL LENGTH WHEN CONNECTED TO WET PIPE SPRINKLER SYSTEM

NOTE: STANDARD DRY PENDENT IS SHOWN, HOWEVER, MINIMUM EXPOSED BARREL LENGTH APPLIES TO ALL STYLES OF DRY SPRINKLERS CONNECTED TO A WET PIPE SYSTEM.

AMBIENT TEMPERATURE EXPOSED TO DISCHARGE END OF SPRINKLER**	EXPOSED BARREL AMBIENT TEMPERATURE		
	40°F/4°C	50°F/10°C	60°F/16°C
	EXPOSED MINIMUM BARREL LENGTH** (FACE OF FITTING TO TOP OF CEILING)***		
	IN. (MM)	IN. (MM)	IN. (MM)
40°F (4°C)	0	0	0
30°F (-1°C)	0	0	0
20°F (-7°C)	4 (100)	0	0
10°F (-12°C)	8 (200)	1 (25)	0
0°F (-18°C)	12 (300)	3 (75)	0
-10°F (-23°C)	14 (350)	4 (100)	1 (25)
-20°F (-29°C)	14 (350)	6 (150)	3 (75)
-30°F (-34°C)	16 (400)	8 (200)	4 (100)
-40°F (-40°C)	18 (450)	8 (200)	4 (100)
-50°F (-46°C)	20 (500)	10 (250)	6 (150)
-60°F (-51°C)	20 (500)	10 (250)	6 (150)

* FOR AMBIENT TEMPERATURES EXPOSED TO THE DISCHARGE END OF THE SPRINKLER THAT OCCUR BETWEEN THE VALUES LISTED, USE THE NEXT COOLER TEMPERATURE.

** THE MINIMUM EXPOSED BARREL LENGTH IS NOT THE SAME AS THE "A" DIMENSION. THE MINIMUM EXPOSED BARREL LENGTH IS BASED ON A PROPERLY SEALED PENETRATION WITH A MAXIMUM WIND VELOCITY ON THE EXPOSED SPRINKLER OF 30 MPH (48 KM/H). LONGER EXPOSED BARREL LENGTHS WILL HELP AVOID FREEZING OF THE WET PIPING WHERE HIGHER WIND VELOCITY IS EXPECTED.

*** THE MINIMUM EXPOSED BARREL LENGTH IS MEASURED FROM THE FACE OF THE FITTING TO THE INSIDE FACE OF THE INSULATION, WALL, OR CEILING LEADING TO THE COLD SPACE, WHICHEVER IS CLOSEST TO THE FITTING.

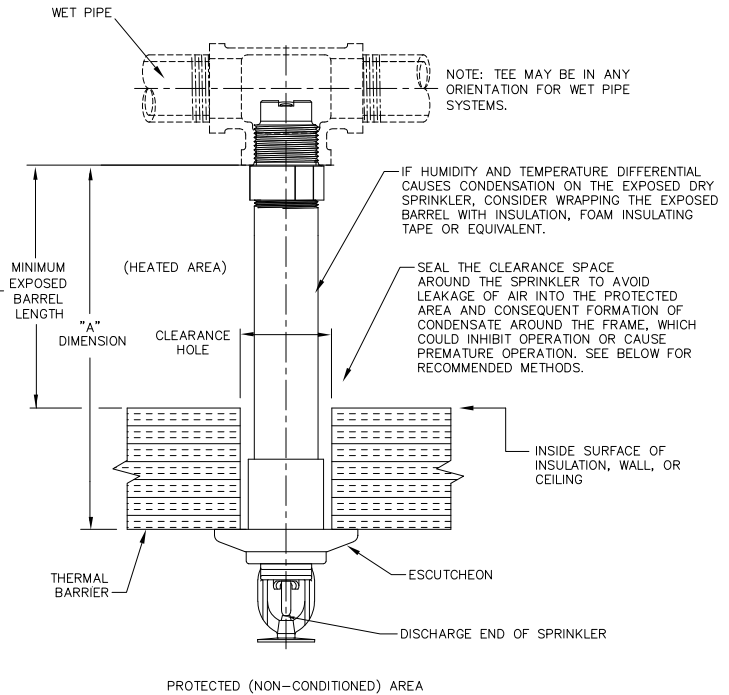

RECOMMENDED DRY SPRINKLER SEAL ARRANGEMENTS (DRY SPRINKLER WITH STANDARD ESCUTCHEON SHOWN)

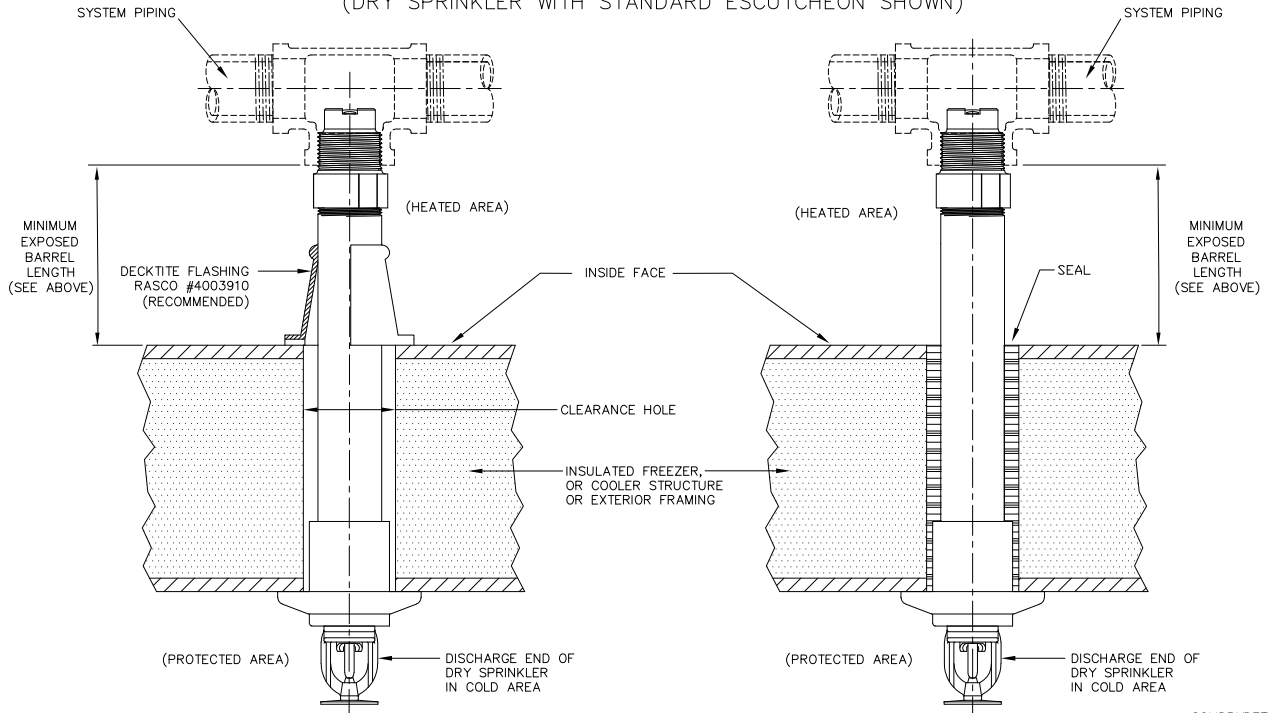

CAUTION

RELIABLE DRY SPRINKLERS MAY BE INSTALLED IN A LISTED CPVC SPRINKLER FITTING, ONLY UPON VERIFICATION THAT THE FITTING DOES NOT INTERFERE WITH THE SPRINKLER'S INLET.

Do not install dry sprinklers with standard inlets into CPVC fittings that have an internal obstruction; this will damage the sprinkler, the fitting, or both.

Short inlet ("PL") versions of Reliable dry sprinklers are available that may or may not be compatible with fittings having internal obstructions in existing installations. Sprinklers with the short inlet ("PL") should only be installed in CPVC fittings of wet-pipe systems.

In all cases, verify sprinkler and fitting dimensions prior to installation to avoid interference.

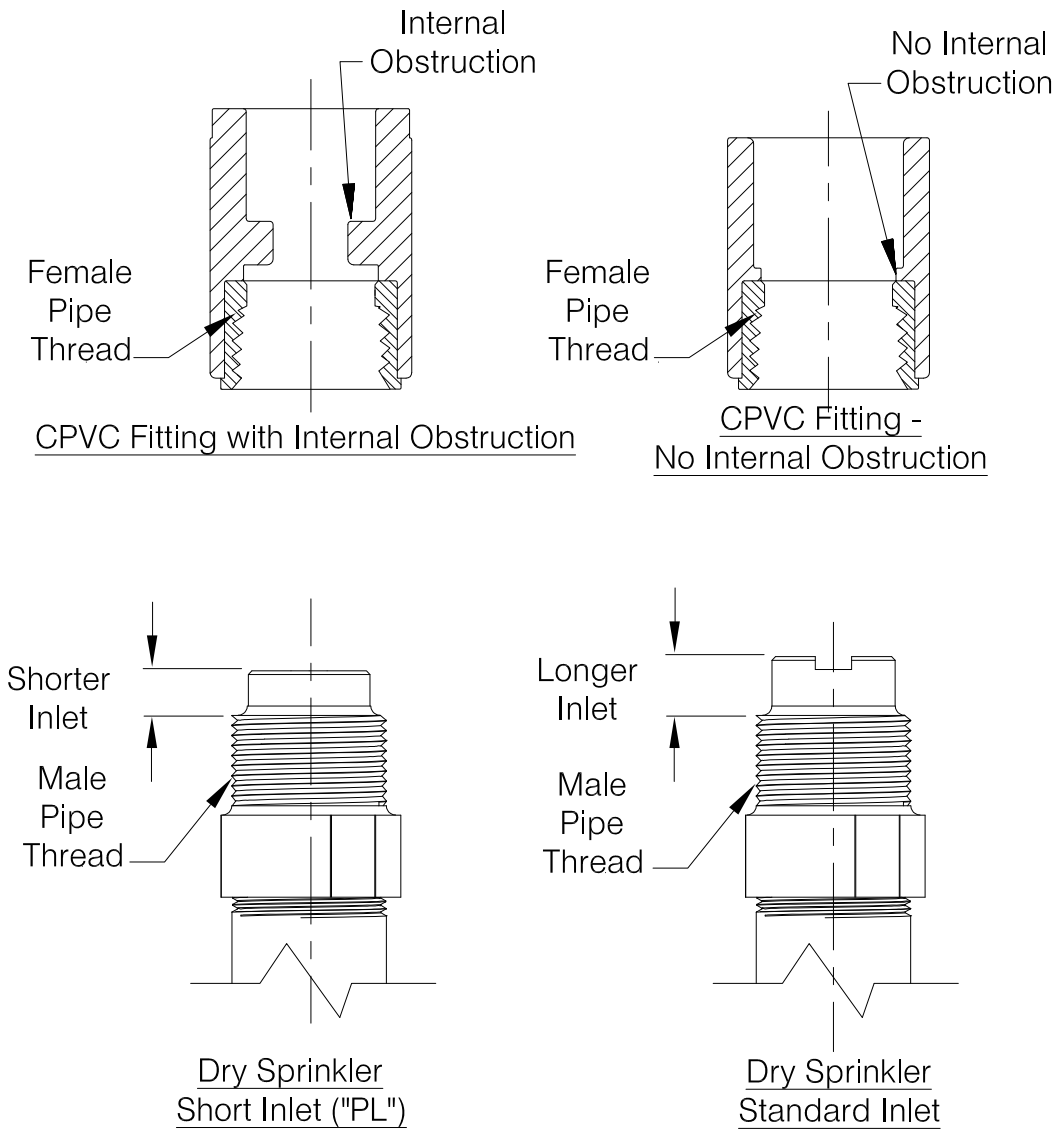

BE SURE TO ORDER THE CORRECT SPRINKLERS FOR YOUR APPLICATION

COMDRYDET2

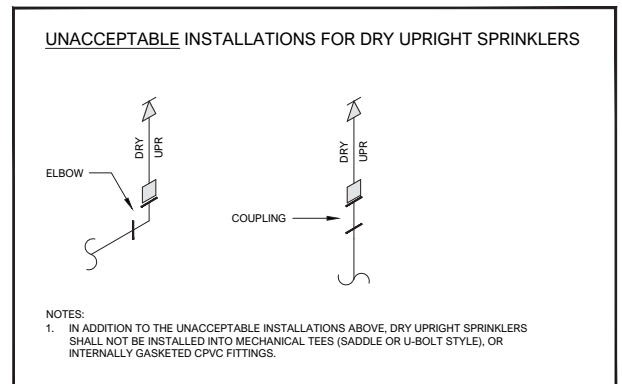
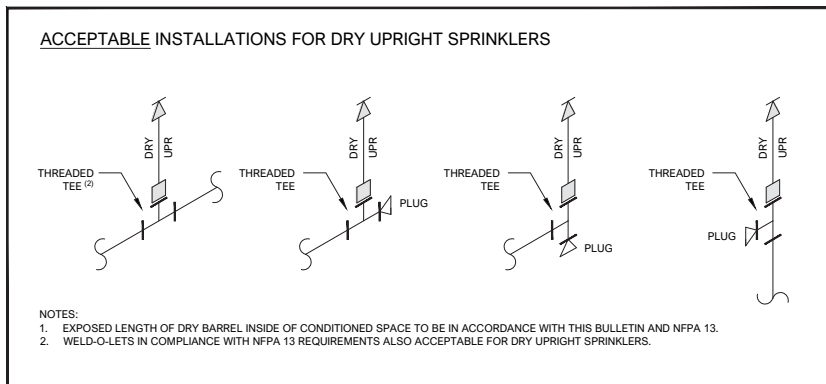
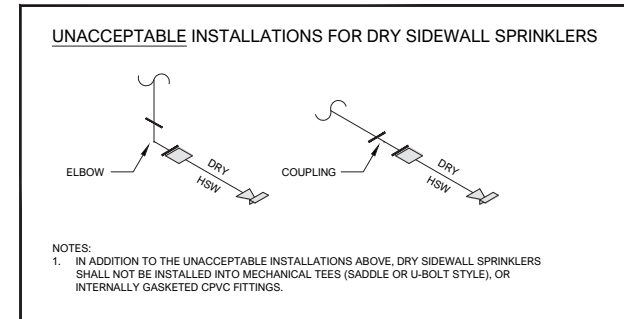
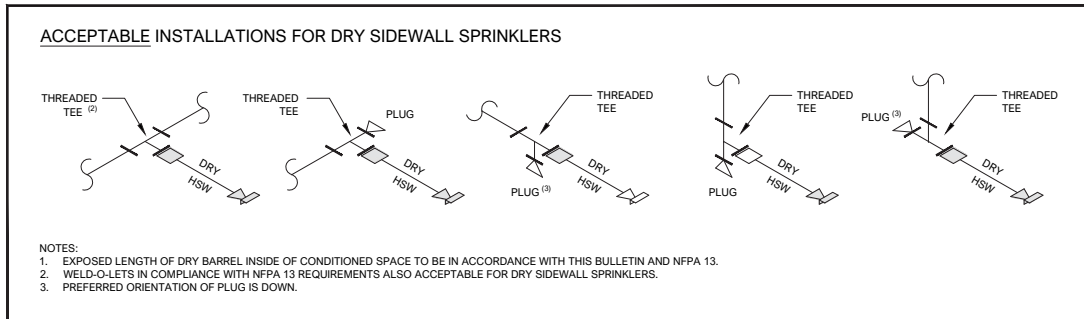
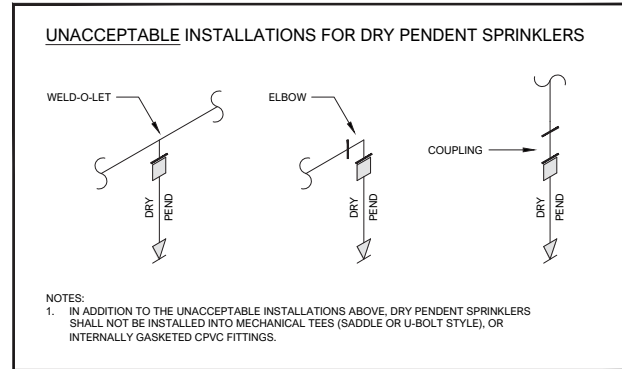
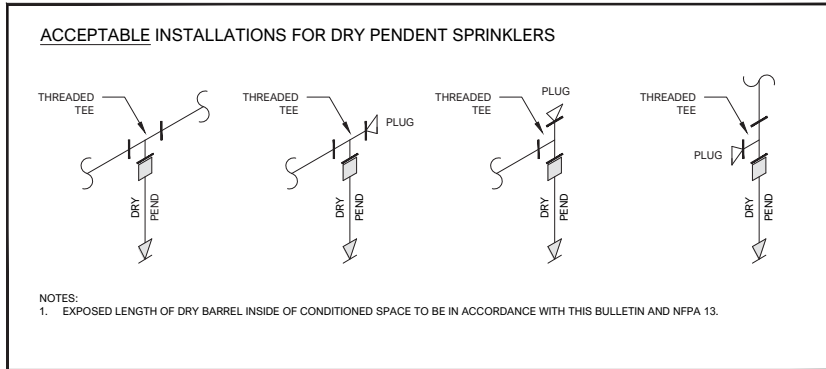

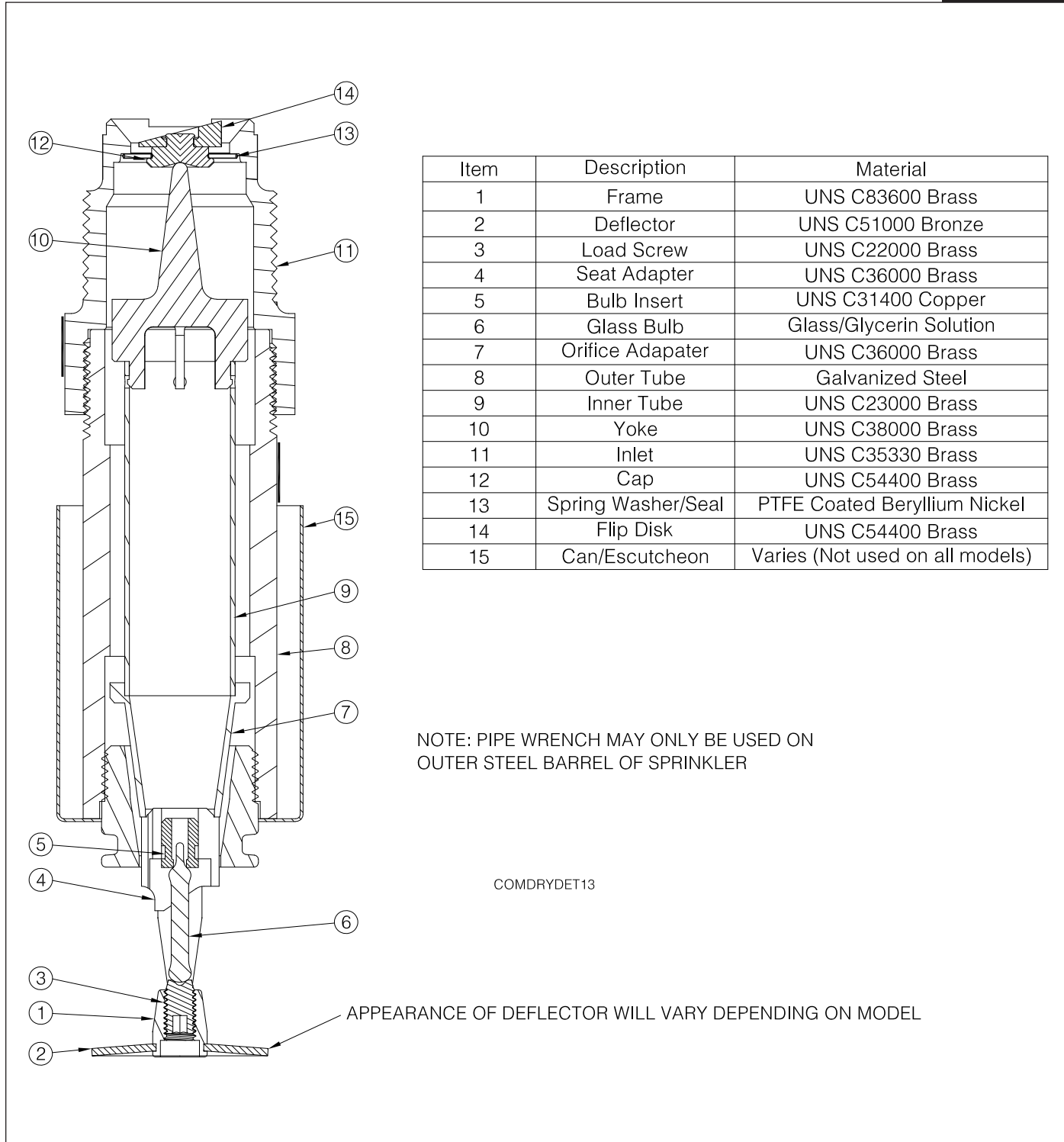

Wrench Options



F3R Wrench
(Standard & HB trims)



XLO2 Wrench
(FP Recessed and CCP trims)

Maintenance

Reliable Model F3-80 series sprinklers should be inspected and the sprinkler system maintained in accordance with NFPA 25, as well as the requirements of any Authorities Having Jurisdiction. Prior to installation, sprinklers should remain in the original cartons and packaging until used. This will minimize the potential for damage to sprinklers that could cause improper operation or non-operation.

Do not clean sprinklers with soap and water, ammonia liquid or any other cleaning fluids. Remove dust by gentle vacuuming without touching the sprinkler.

Replace any sprinkler which has been painted (other than factory applied). A stock of spare sprinklers should be maintained to allow quick replacement of damaged or operated sprinklers. Failure to properly maintain sprinklers may result in inadvertent operation or non-operation during a fire event.

Guarantee

For the Reliable Automatic Sprinkler Co., Inc. guarantee, terms, and conditions, visit www.reliablesprinkler.com.

Patents

US Patent No. 7,841,418

Ordering Information

Specify:

Model F3-80 Dry Sprinkler

- Pendent
- Horizontal Sidewall

Trim Style

- Standard Escutcheon
- HB Escutcheon
- FP Recessed Escutcheon
- CCP Cover Plate (Pendent only)
- No Escutcheon

Temperature Rating

- See available temperatures (depending on trim style and approvals) on pages 2-10

Finish

- See available finish combinations (depending on trim style and approvals) on pages 2-10

Length

- For dry pendent and sidewall sprinklers with trim, "A" dimension is measured from face of fitting to face of finished ceiling or wall in 1/4" (6mm) increments.
- For dry sprinklers with no trim, order dimension is from face of fitting to deflector in 1/4" (6mm) increments.

Note: Lengths are based upon a normally gauged pipe thread "make-up" of .60 inch (15mm) per ANSI B2.1 (approximately 7-1/2 threads).

Installation Wrench

- Model F3R (Standard & HB trims)
- Model XLO2 (FP Recessed & CCP trims)