

MODEL 2000ss Double Check Assembly

AMES^{CO.}
FLUID CONTROL SYSTEMS



AMES BACKFLOW ASSEMBLIES: LIGHTER, SHORTER, BETTER FLOWING THAN ANY OTHER

■ Application

The Ames 2000ss provides positive drip-tight closure against the reverse flow of non potable liquids caused by a cross connection. The 2000ss can be used in fire protection systems, irrigation systems and other systems requiring low and intermediate hazard protection.

■ Operation

In normal flow conditions, the independently operating check valves remain closed until there is a demand for water. Each of the check valves in series is designed to open at approximately (1) PSI pressure differential in the direction of flow. At cessation of flow or under a back pressure condition, both check valves will close until the resumption of normal flow.

■ Installation

The 2000ss should be installed with adequate clearance and easy accessibility for maintenance and testing. The 2000ss may be installed vertically or horizontally. Refer to local codes for specific installation requirements.

■ Features

- Lowest documented head loss.
- Non-corrosive 300 series stainless steel construction.
- 50% lighter in weight, reduces installation and handling costs.
- Only assembly ASSE 1015 vertically approved.
- 40% shorter end to end dimensions for compact, inexpensive installation.
- Excellent for retrofit applications.
- Single two-bolt grooved style cover for quick and easy access.

- Simple service procedures, requires no special tools.
- Patented* cam-check assembly for long term reliability, low head loss, ease of serviceability.

*Patent # 5,046,525

■ National Approvals**

Approved by national approval agencies.



MODEL 2000ss Double Check Assembly

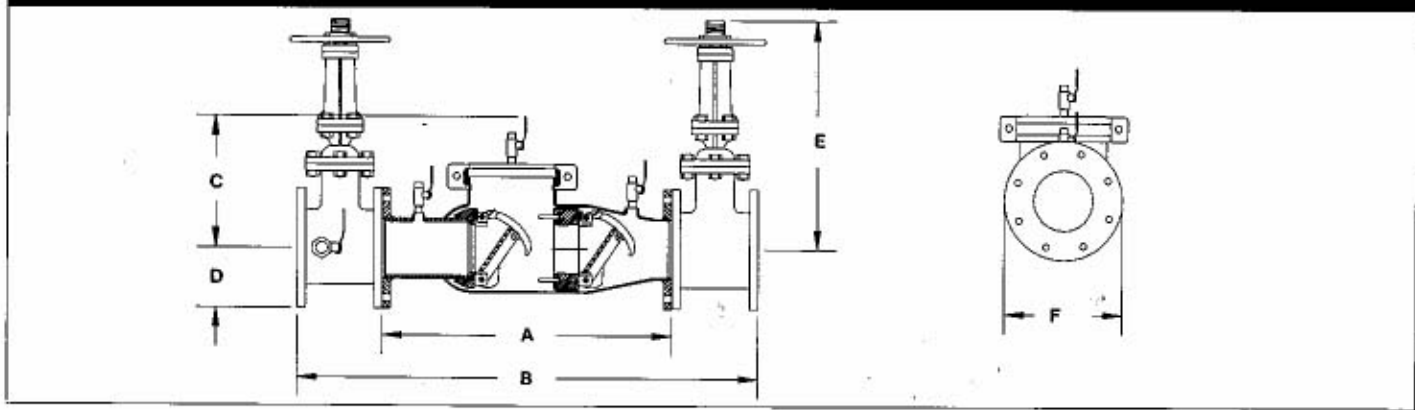

Ames 2000ss - Weights & Dimensions (inches)

SIZE	A	B	C	D	OSY E (Open)	F	Net Wt. (lb.) w/Gates	Net Wt. (lb.) w/o Gates
2 1/2"	22"	37"	10"	3 1/2"	16 1/2"	7"	140#	53#
3"	22"	38"	10"	3 3/4"	22"	7 1/2"	215#	55#
4"	22"	40"	10"	4 1/2"	23 1/2"	9"	225#	58#
6"	27 1/2"	48 1/2"	15"	5 1/2"	30 1/2"	11"	375#	105#
8"	29 1/2"	52 1/2"	15"	6 3/4"	37 3/4"	13 1/2"	561#	169#
10"	29 1/2"	55 1/2"	15"	8"	48"	16"	763#	179#
12"	29 1/2"	57 1/2"	15"	9 1/2"	54"	19"	1033#	209#

Physical Characteristics

Sizes - 2 1/2", 3", 4", 6", 8", 10", 12"
 Rated working pressure - 175 psi
 Hydrostatic Pressure - 350 psi
 Temperature range - 32°F - 110°F
 Flange dimension in accordance with AWWA Class D
 All internal metal parts 300 series stainless steel
 Construction 300 series stainless steel
 Assembly shall be ASSE 1015 approved for vertical installations, AWWA C510-89

2 1/2" & 3" Documented Flow Characteristics (including shut-off valves)

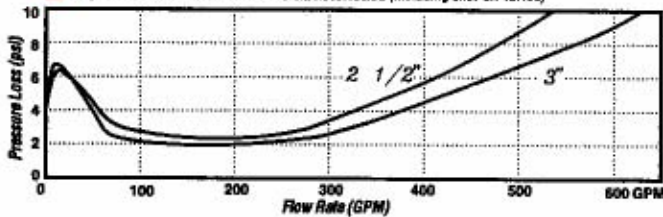

8" Documented Flow Characteristics (including shut-off valves) **

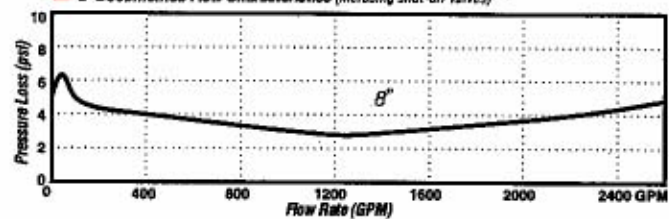

4" Documented Flow Characteristics (including shut-off valves)

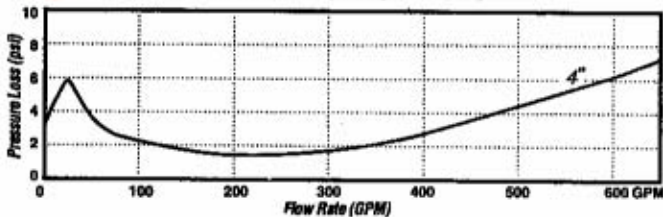

10" Documented Flow Characteristics (including shut-off valves) **

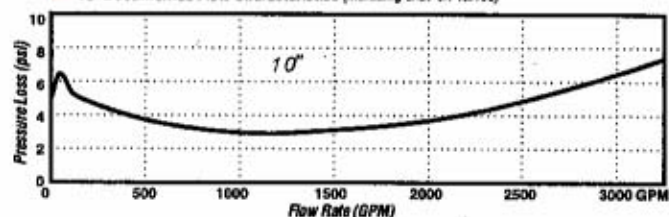

6" Documented Flow Characteristics (including shut-off valves)

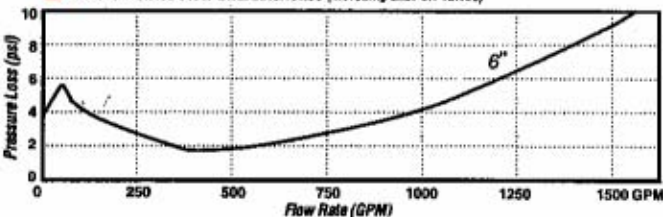

12" Documented Flow Characteristics (including shut-off valves) **

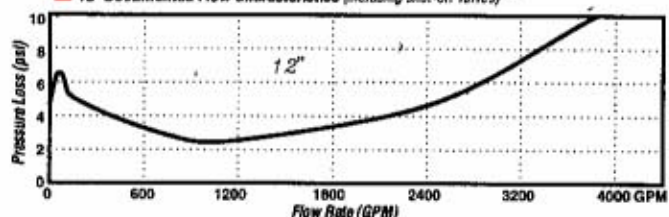

Specifications

The double check shall consist of two independently operated spring loaded cam-check valves, required test cocks, and optional inlet and outlet resilient wedge shut off valves. Each cam-check shall be internally loaded and provide a positive drip tight closure against the reverse flow of liquid caused by back siphonage or back pressure. The modular cam-check includes a stainless steel

spring and cam-arm, rubber faced disc and a replaceable seat. The body shall be manufactured from 300 series stainless steel, 100% lead free through the waterway, with a single two-bolt access cover. No special tools shall be required for servicing. Double check shall be Ames 2000ss.

**Contact the factory for specific approvals