



Features of Maxim backflow assemblies

- Certified Lowest Pressure Loss
- Compact 100% stainless steel relief valve
- Half the weight of the competition
- Entire valve body and quick access sleeve manufactured from 300 Series Stainless Steel
- Approved with gate valves or UL/FM butterfly valves
- Approved in horizontal, "N" pattern, or "Z" pattern installations

Check our Website for approval updates!

- Utilizes groove connections for ease of installation & pipe alignment
- Patented Link-check modules allow ease of serviceability
- Smallest Enclosure
- Made in USA

The Ames Challenge

Ames offers the best performing, easiest to service, lowest installed cost backflow assemblies in the industry. We challenge any backflow manufacturer to disprove these claims, through authorized, 3rd party testing.

MAXIM Series Excellence Matters – Specify It!

400 Reduced Pressure Principle Assembly

500 Reduced Pressure Principle Detector Assembly



Engineering the Curve - Certified Flow Characteristics

Maxim 400/500 flow characteristics (Including OS&Y shut-offs)

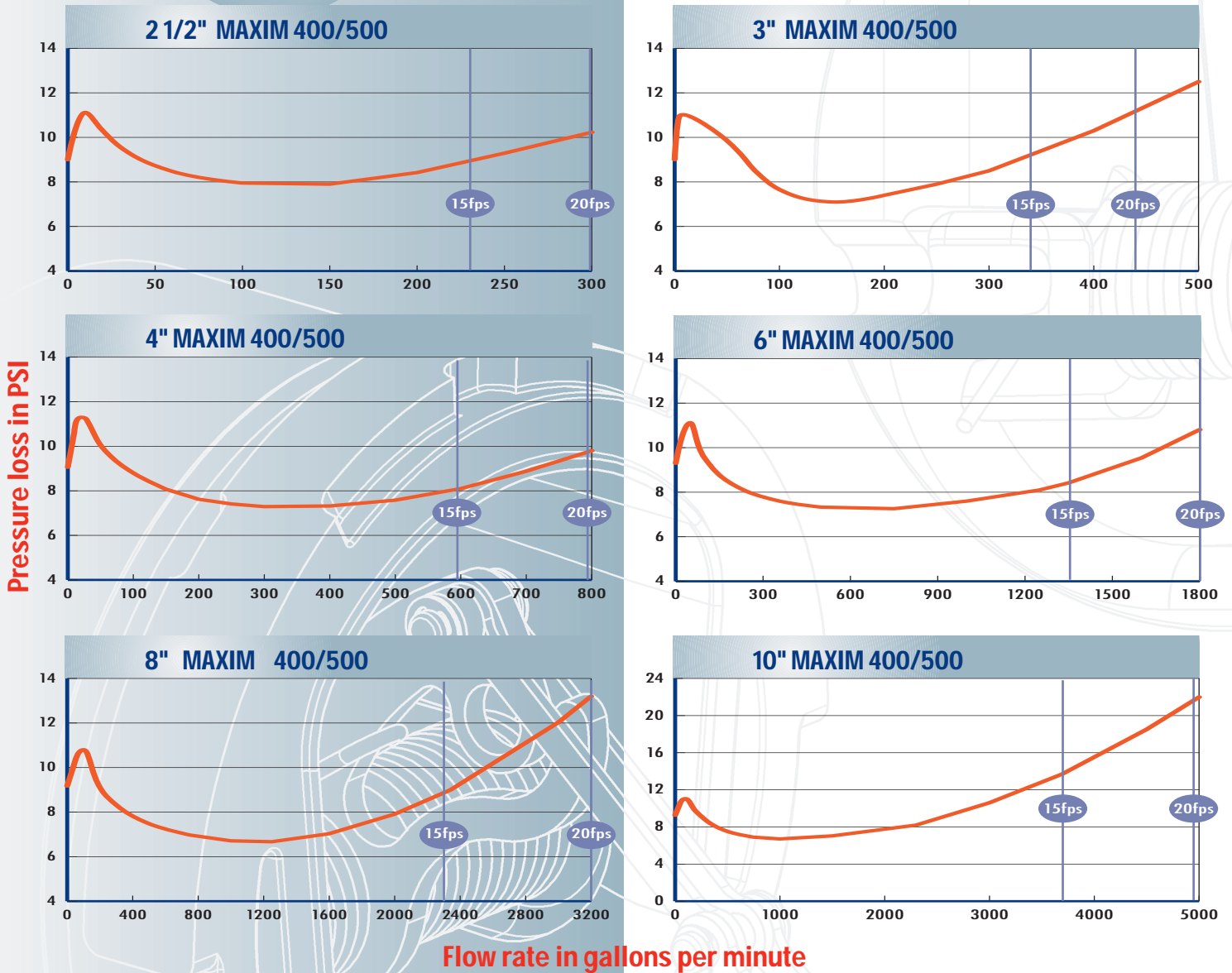

The Ames Challenge - Pressure Loss

Compare 4" Reduced Pressure Assembly with Shutoff Valves @ 15 fps (595 gpm)

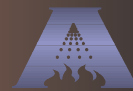

Backflow Assembly	Pressure Loss (PSI)	% Higher Than Ames
Maxim 400	8.0	
Febco 860 - GPC 3/01	10.0	25%
Wilkins 375 - BF 375	11.1	37%

Maxim 400/500 dimensions & weight

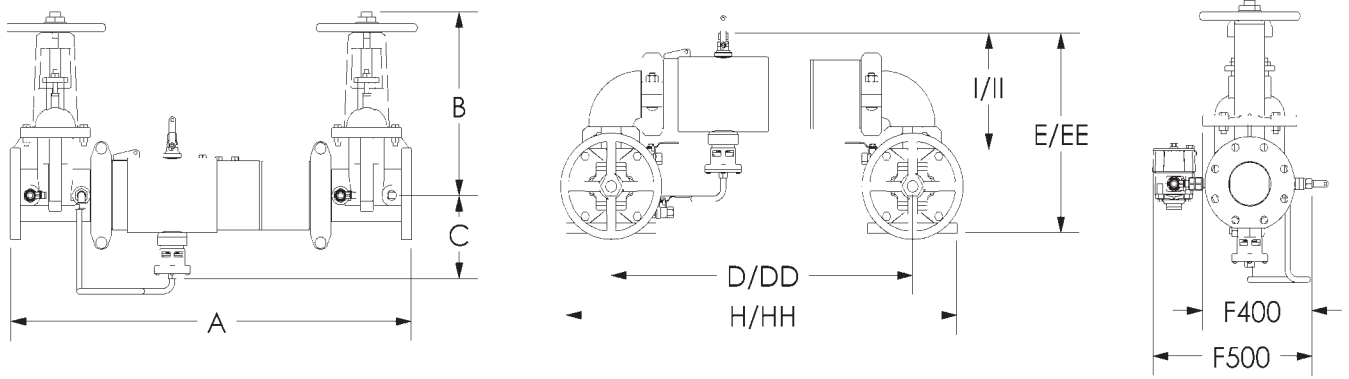

Size	w/ gate valves (In.)							w/ ul/fm butterfly valves (In.)							N BFG Weight		
	A	OS&Y B	C	D	E	H	I	F/400	F/500	OS&Y Weight	DD	EE	HH	II		F/400	F/500
2½"	31	16¾	6½	22	15¼	29½	8¾	9¾	13¾	128 lbs	23½	15½	32½	9½	11¼	11¼	67 lbs
3"	31¼	18¾	6¼	22¾	16¼	30	9¾	10¼	14¼	148 lbs	24½	16¼	34	10¼	12¼	12¼	70 lbs
4"	40½	22¾	8	30¾	19¼	39¾	11	11¼	15¼	222 lbs	32¾	18¼	42½	12	13¼	13¼	145 lbs
6"	48¾	30¾	9½	38	23¼	49	14¾	15½	19½	393 lbs	40	21¾	50¼	15¼	16¼	16¼	254 lbs
8"	55	37¾	10½	45¾	27¼	58¾	16¾	17¾	21¾	567 lbs							
10"	57½	45¾	11¼	50	32½	66	17¼	20¼	24¼	784 lbs							

Butterfly valves available for shutoff valves

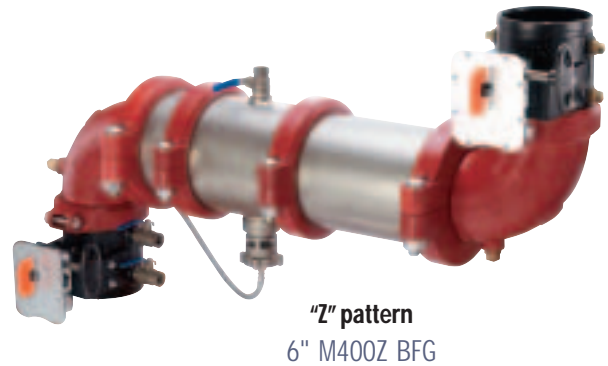
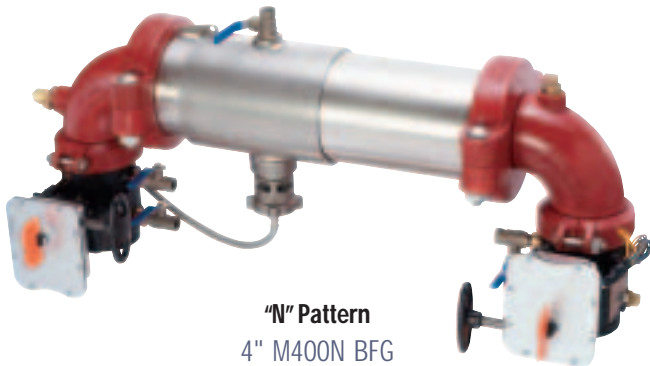

The Ames Challenge - Assembly Weight

Compare 4" Reduced Pressure Assembly with shutoff Valves

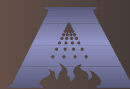

Backflow Assembly	Weight (lbs)	% Heavier Than Ames
Maxim 400 w/BFV	145	
Febco 860 - w/OS&Y — GPC 3/01	334	130%
Wilkins 375 - BF 375	288	98%

Advantages of UL/FM butterfly valves

- Butterfly valves have built-in tamper switch wiring
- Backflow assembly is lighter & more compact
- Groove couplings allow ease of installation & pipe alignment
- All butterfly valves display flow indicator flag

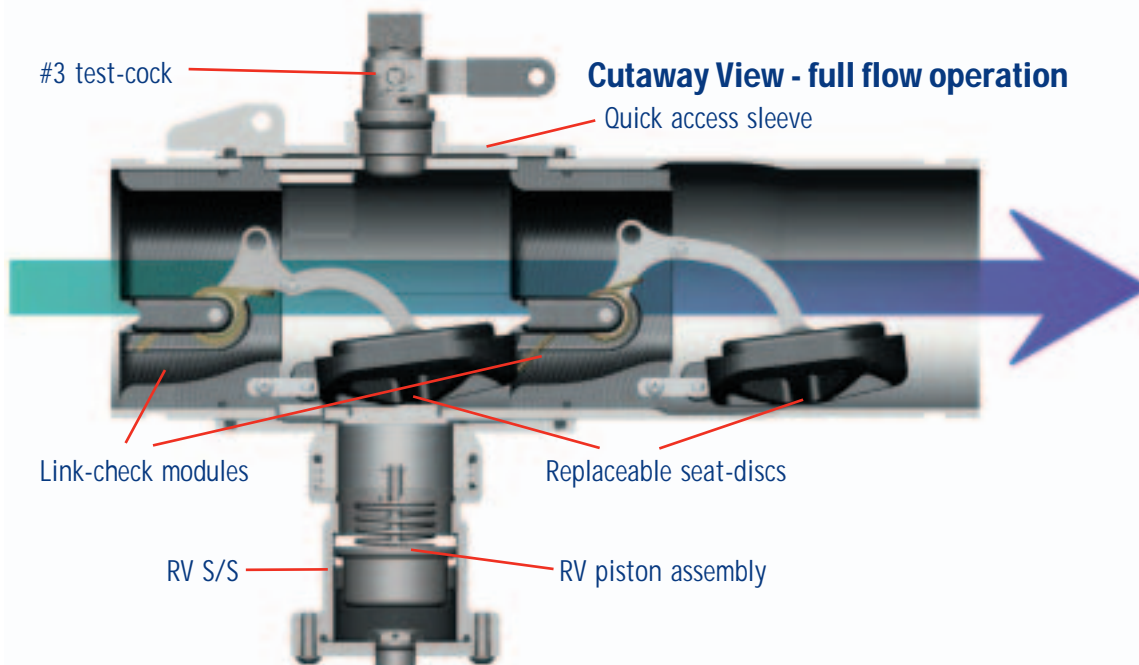

Normal Operation

In normal flowing operation the independent check valves will be open and the pressure differential relief valve located between the two check valves, the area called the zone, will automatically open and close to maintain the zone pressure at least 2 PSI lower than the inlet pressure. If demand for flow stops, the differential pressure relief valve will automatically open and discharge water to maintain the zone at a pressure of 2 PSI lower than the inlet pressure. After the pressure differential is reestablished, the differential pressure relief valve will automatically close.

Applications – Maxim 400

Reduced Pressure Principle Backflow Assemblies (RP's) provide protection to the potable water system from contamination in accordance with national plumbing codes. RP's are normally used in high-hazard applications for protection against both back siphonage, backpressure and the fouling of either check valve.

Applications – Maxim 500

Reduced Pressure Principle Detector Assemblies (RPDA) are installed on fire protection systems connected to the public water supply in a high-hazard application. In addition to the features of the Maxim 400, the Maxim 500 is used to monitor unauthorized use of water from the fire protection system.

Approvals

Contact the factory or visit the website:
www.amesfirewater.com

Specifications

The Reduced Pressure Backflow Assembly shall consist of two independent Link check modules, a differential pressure relief valve located between and below the two modules, drip tight inlet and outlet shutoff valves, and required test cocks. Both check modules and the relief valve shall be contained within a sleeve accessible single housing constructed from 300 series stainless steel with groove end connections. Link checks shall have reversible elastomer disks and in operation shall produce drip tight closure against the reverse flow of liquid caused by back pressure or back siphonage. Assembly shall be manufactured in the USA. Assembly shall be MAXIM 400/500 manufactured by AMES of Sacramento, California.

Characteristics and Materials

Rated Working Pressure	175 PSI
Temperature Range	33 F – 140 F
Body Construction	300 Series Stainless Steel
End Connection	Groove per AWWA C-606 (IPS) or Flange per ANSI B16.1, Class 125



Division of Watts Industries

875 National Drive Suite #107
 Sacramento, CA 95834
 Phone 916.928.0123
 Fax 916.928.9333
www.amesfirewater.com