

Reliable®

2½" (65 mm), 76mm 3" (80 mm), 4" (100 mm), 6" (150 mm) & 165 mm Model G Riser Check Valves

Features

1. Grooved end connections.
2. Compact, lightweight design.
3. Non-slamming, spring loaded clapper to minimize water hammer.
4. Approved for horizontal and vertical installation.
5. Stream-lined body design provides very low friction loss.
6. Elastomer faced clapper provides leak-free, non-sticking sealing.

Reliable Model G Riser Check Valves are intended for installation in wet pipe fire protection system risers and preaction systems using supervisory air as low as 1 psi (0,07 bar). The Riser Check Valve and Trim Kit (Figure 1) with a water flow detector can provide an electric alarm, and is a cost effective alternative to an alarm valve in installations not requiring a mechanical alarm.

Riser Check Valves are factory tapped for 1¼" (or 2") NPT and ½" NPT system connections and for ¼" NPT supply connection (Ref. Figure 3).

Grooved end connections provide fast and easy installation using listed or approved mechanical grooved couplings. Rigid style grooved couplings can be used for positive clamping to resist flexural and torsional loads.

Riser Check Valves and associated riser equipment should periodically be given a thorough inspection and test. NFPA 25 provides minimum maintenance requirements. Check valves should be inspected and operated at least annually. Parts should be replaced as required.

When Model G Riser Check Valves are installed vertically, the direction of the flow arrow must point upward. For horizontal installations, the hinge pin must be located at the top. In preaction systems, the valves must be installed vertically.

Valve Description

1. Rated working pressure - 250 psi (17,2 bar).
2. Factory hydrostatic test pressure - 500 psi (34,5 bar). Friction loss, expressed in equivalent length of Sch. 40 pipe with C = 120 (based on Hazen-Williams formula) and a flowing velocity of 15 ft/s (4.6 m/s), is:
2½" (65mm) & 76mm - 7 ft (2.13 m)
3" (80mm) - 7 ft (2.13 m)
4" (100mm) - 10 ft (3.05 m)
6" (150mm) & 165mm - 16 ft (4.88 m)
See Bulletin 807 for Pressure Drop (psi) vs. Flow Rate (gpm) data chart.

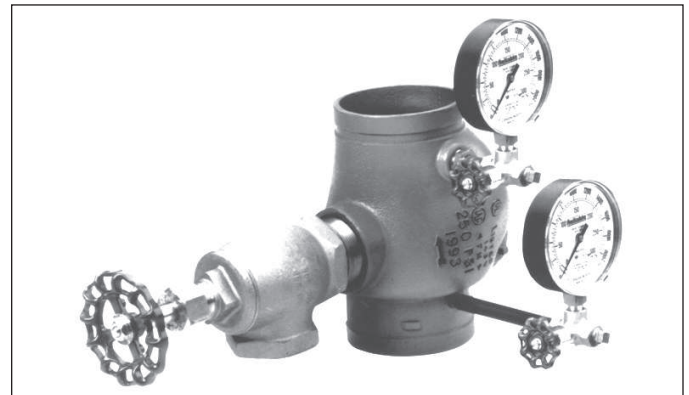

Figure 1

4. Standard grooved end dimensions per ANSI/AWWA C606.
5. Dimensions A - E (Refer to figure 2).

2½" (65mm) & 76mm Valve:				
A=7.12" (181mm)	B=4.81" (122mm)	C=3.88" (98mm)	D=11.38" (289mm)	E=3.01" (76mm)
3" (80mm) Valve:				
A=7.62" (194mm)	B=5.06" (129mm)	C=4.00" (102mm)	D=11.62" (295mm)	E=3.56" (90mm)
4" (100mm) Valve:				
A=8.44" (214mm)	B=6.19" (157mm)	C=4.00" (102mm)	D=13.56" (344mm)	E=4.12" (105mm)
6" (150mm) & 165mm Valves:				
A=10.25" (260mm)	B=7.06" (179mm)	C=5.12" (130mm)	D=14.44" (367mm)	E=5.40" (137mm)

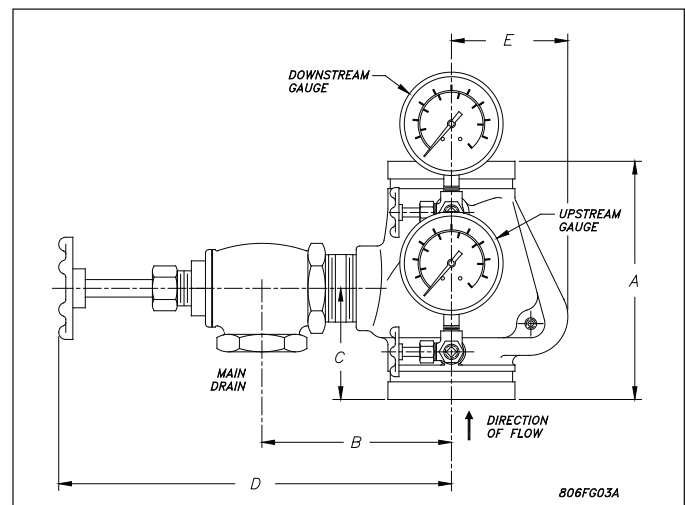

Figure 2

6. Shipping weight (including Trim Kit):
2½" (65mm) & 76mm - 14 lbs. (6.4 kg)
3" (80mm) - 15 lbs. (6.8 kg)
4" (100mm) - 24 lbs. (11.0 kg)
6" (150mm) & 165mm - 45 lbs. (20.4 kg)

Refer to figure 3.

Item No.	Part Name	Material	Qty.	Part Number					
				2½" (65mm)	76mm	3" (80mm)	4" (100mm)	6" (150mm)	165mm
1*	Valve Body	Gray Iron, ASTM-A48 Class 30A	1	91005002	91005001	91005003	91005004	91005006	91005005
2*	Seat	Bronze C83600 or C93200, ASTM-B505	1	96020200	96020200	96020300	96020400	96020600	96020600
3	Clapper	Stainless Steel 304, ASTM-A240	1	91816112	91816112	91816113	91816114	91816116	91816116
4	Facing Seal **	EPDM Rubber	1	95520200	95520200	95520300	95520400	95520600	95520600
5	Clamping Ring	Stainless Steel 304, ASTM-A240	1	95290300	95290300	95290300	95290400	95290600	95290600
6	Gasket **	EPDM Rubber	1	93720604	93720604	93710604	93720604	93720604	93720604
7	Spring	Stainless Steel 302, ASTM-A313	1	96400300	96400300	96400300	96400400	96400600	96400600
8	Hinge Pin	Stainless Steel 303, ASTM-A582	1	95000280	95000280	95000300	95006824	95000600	95000600
9	Bolt	Stainless Steel 304, ASTM-F593	1	91090600	91090600	91090600	91090400	91090600	91090600
10	Locknut **	Stainless Steel 303, ASTM-F594	1	94913816	94913816	94913816	94913816	94913816	94913816
11	Plug, ½"NPT	Steel	1	—	—	—	—	—	—
**	Replacement Seal Kit		1	6888040025	6888040025	6888040030	6888040040	6888040060	6888040060
	Body - Seat Sub - Assembly		1	91005202	91005201	91005203	91005204	91005206	91005205

* Not field replaceable.

Trim Kit Description

Main Drain:

- 1¼" (32 mm) angle valve and close nipple, 2½" (65 mm), 76mm and 3" (80 mm) sizes.
- 2" (50 mm) angle valve and close nipple, 4" (100 mm), 6" (150 mm) & 165 mm sizes.

Upstream and Downstream Side (all sizes):

- 300 psi (20,7 bar) water pressure gauge (2 req'd.).
- ¼" (6 mm) 3-way globe valve (2 req'd.).
- ¼" x 5" (6 mm x 127 mm) nipple (upstream only).
- ¼" x 1½" (6 mm x 38 mm) nipple (downstream only).
- ¼" (6 mm) plug (2 req'd.).

Approvals

1. Listed by Underwriters Laboratories, Inc.
2. Listed by Underwriters Laboratories of Canada.
3. Approved by Factory Mutual Research Corp.
4. NYC MEA 258-93E.

Valve Disassembly (Refer to figure 3)

1. Close the main water supply valve and drain the system.
2. Remove the check valve from the piping system.
3. Inspect the Seat (2) for any cuts, scrapes and dents. Replace the valve if any damage is found.
4. To replace the Facing Seal (4), remove the Clapper (3), unscrew the Locknut (10) and remove the retention Bolt (9).

Valve Reassembly (Refer to figure 3)

1. Thoroughly clean the Clapper (3). Insert the retention Bolt (9) with a new Gasket (6).
2. Place the new Facing Seal (4) and the Clamping Ring (5) against the Clapper (3). Tighten the new Locknut (10) to 21 in. lbs. (2.3 N•m) torque in 2½" (65mm), 76mm and 3" (80mm) sizes and to 52 in. Lbs. (5.7 N •m) in 4" (100mm), 6" (150mm) and 165mm sizes.

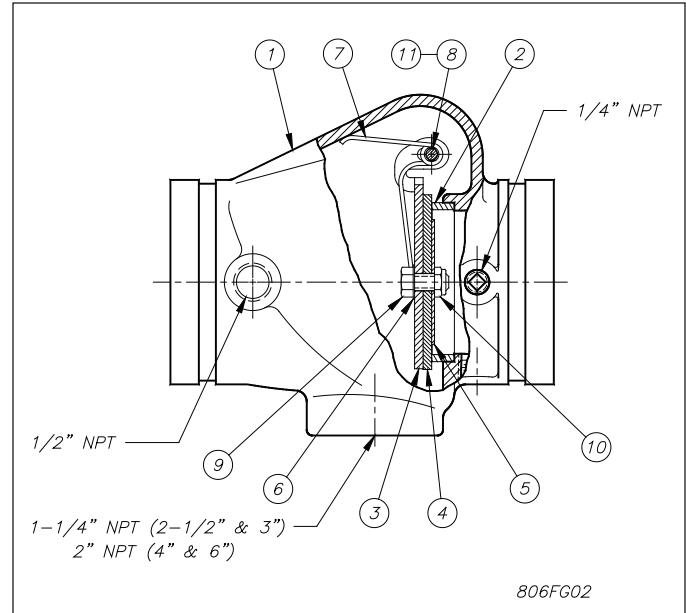

Figure 3

3. Insert the clapper assembly into the valve through the downstream opening. Reinsert the Hinge Pin (8) while holding the coils of the properly oriented Spring (7) in place. Install the Hinge Pin Plug (11).
4. Reinstall the check valve in the system.
5. Place the system back in service.

Ordering Information

Specify:

1. Model G Riser Valve.
2. Size.
3. Riser Trim Kit (ordered separately), specify valve size.

Contact the installing contractor or Reliable if any difficulties are experienced. Should replacement parts be needed, use only genuine Reliable parts.

The equipment presented in this bulletin is to be installed in accordance with the latest published Standards of the National Fire Protection Association, Factory Mutual Research Corporation, or other similar organizations and also with the provisions of governmental codes or ordinances whenever applicable. Products manufactured and distributed by Reliable have been protecting life and property for over 90 years, and are installed and serviced by the most highly qualified and reputable sprinkler contractors located throughout the United States, Canada and foreign countries.

Manufactured by



The Reliable Automatic Sprinkler Co., Inc.
 (800) 431-1588 Sales Offices
 (800) 848-6051 Sales Fax
 (914) 829-2042 Corporate Offices
 www.reliablesprinkler.com Internet Address



Revision lines indicate updated or new data.

EG. Printed in U.S.A 07/11

PN 999970070