

Reliable®

Single Interlock Electric Release Preaction System 8" (200 mm) Size

Instructions for Installation, Operation, Care and Maintenance 2 PSI (0,14 bar) Pneumatic Supervising Pressure with Electric Actuation

- Available with 175 psi (12,1 bar) or 250 psi (17,2 bar) Rated Solenoid Valve
- Externally Resettable Clapper
- One Main Drain

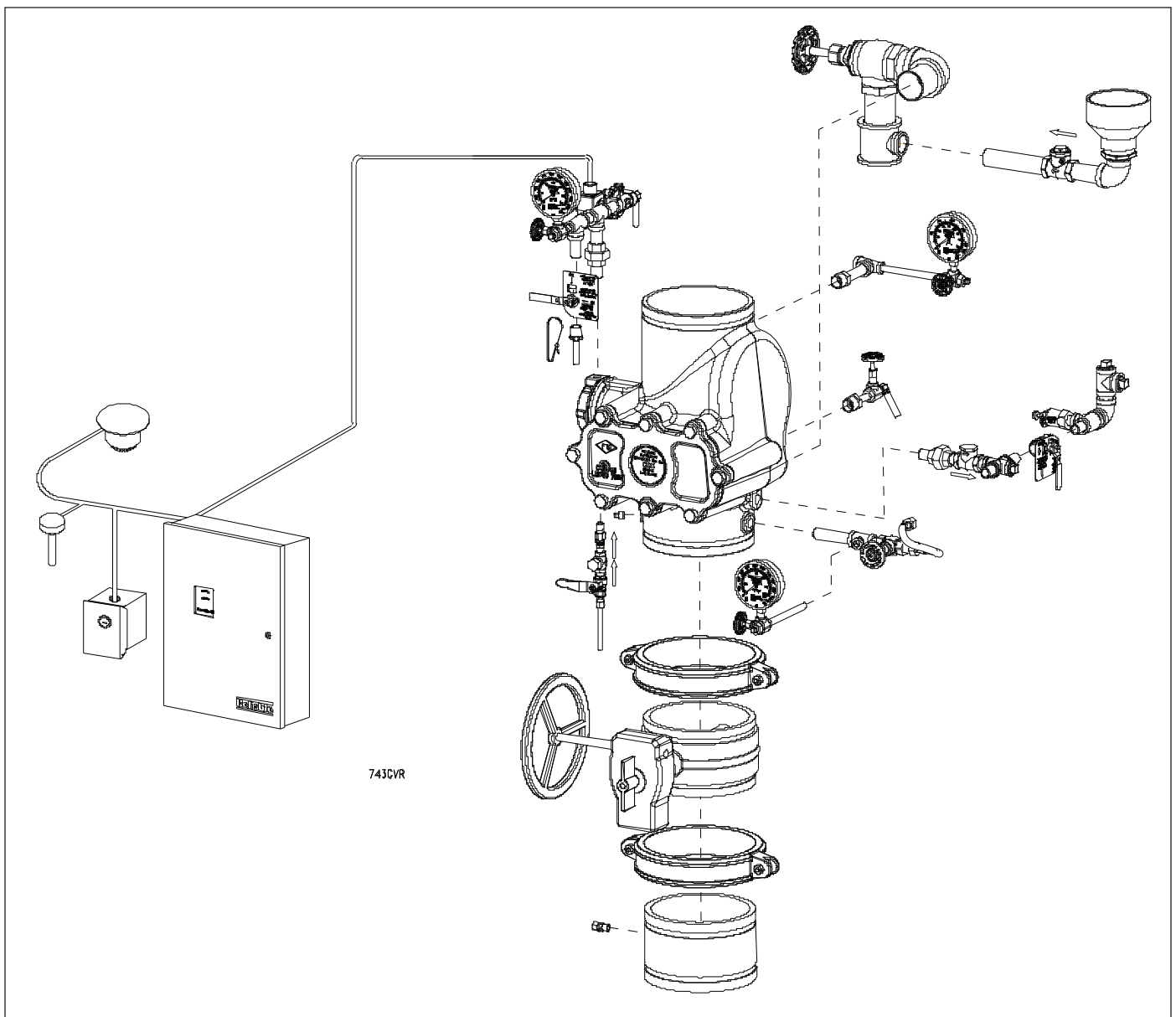

General Description

Single Interlock Preaction Systems are designed for water-sensitive areas that require protection from inadvertent water flow into the sprinkler system piping.

Sprinkler piping in single interlock systems can effectively be supervised by means of a Reliable Model B Air Compressor Panel or Model C Pressure Maintenance Device. Loss of 2 psi (0,14 bar) supervising pneumatic pressure, due to a damaged sprinkler or sprinkler pipe will not cause water to flow through the Model DDX Deluge Valve and into the system piping. A significant loss of pneumatic pressure will activate a trouble-annunciating device when the system pressure falls below 0.7 psi (0,05 bar).

When one electrical detector senses the presence of fire, the electrical releasing control panel activates fire alarm devices and latches the normally-closed solenoid valve (175 psi (12,1 bar) or 250 psi (17,2 bar) Rated) in the open position (**Note:** Arranging detectors in a cross-zoned pattern will require operation of two detectors before the solenoid valve can open). The solenoid valve, when closed, retains sufficient water pressure in the pushrod chamber of the Model DDX Deluge Valve to maintain it closed. Energizing the solenoid valve relieves the water pressure, thus opening the Deluge Valve and allowing water to flow into the sprinkler system.

To fully operate a cross-zoned single interlock system, two electrical detectors must activate and a sprinkler head must open. During the early stages of a fire, smoke or heat activates the first detector, which causes the control panel to produce a local alarm and an alarm at the main fire alarm panel. Electrical relays inside the releasing control panel can be used to shut down air moving equipment or activate security doors and other electrical devices when the panel goes into the first alarm condition. Subsequent activation of a second, nearby or adjacent, detector will cause the panel to energize the solenoid valve open and release water into the sprinkler system piping. Water flowing into the sprinkler system piping will simultaneously produce water pressure that causes the transfer of contacts in the pressure switch mounted in the Reliable Single Interlock Preaction System's riser assembly. This pressure switch can electrically initiate the shut down or startup of equipment, such as computers or other second alarm devices. The flow of water into the sprinkler system piping effectively converts the dry system into a wet pipe system. In the event that the fire subsequently produces sufficient heat to operate a sprinkler head, water will flow from that sprinkler, controlling or suppressing the fire.

The major benefits of a single interlock preaction system, when compared with a wet pipe (deluge) system are as follows:

- A fire alarm sounds prior to the operation of a sprinkler head, which may enable extinguishing the fire by handheld means before the actual operation of any sprinklers and subsequent water damage.
- A trouble annunciator signals whenever the integrity of the piping or sprinklers is accidentally or intentionally disturbed; however, no water flow or water damage will occur at that time.
- Speedy detection and an early fire alarm are provided by fire detectors, without the delay associated with water delivery time in the event of a fire. Note that with a wet pipe system, the fire alarm is delayed until after water has begun flowing from an operated sprinkler head.

At the heart of Reliable's Single Interlock Preaction System is the Model DDX Deluge Valve. This Deluge Valve is a hydraulically operated, straight-through-design, differential latching clapper-type valve (see Fig. 1). System maintenance is simplified since priming water is not required and the Deluge Valve can be reset externally without cover removal. This is accomplished by pushing in and turning the external reset knob at the rear of the Deluge Valve (see Fig. 1). This feature provides a significant system-restoration time advantage.

The Reliable Single Interlock Preaction System trim set (see Fig. 2) provides all of the necessary equipment for connections to the Model DDX Deluge Valve's pushrod chamber inlet and outlet ports, the 2" (50 mm) main drain, alarm devices, air supply, water supply, and required pressure gauges. This trim set is available in individual parts, in time-saving, segmentally assembled kit forms, or fully assembled to the Model DDX Deluge Valve (with or without a control valve).

Listings & Approvals

Reliable 8" (200mm) Single Interlock Preaction Systems are Underwriters Laboratories, Inc. Listed and UL certified for Canada (cULus) in the Special System Water Control Valves – Deluge Type (VLFT) category.

Reliable 8" (200mm) Single Interlock Preaction Systems are certified by Factory Mutual Approvals (FM). Factory Mutual does not approve the use of smoke detectors or cross-zoned detectors in preaction systems.

Reliable Single Interlock Preaction Systems are UL Listed and FM Approved only when used with the trim components shown in Fig. 2.

DDX VALVE CLAPPER IN "OPEN", "CLOSED"
AND "LATCHED" POSITIONS

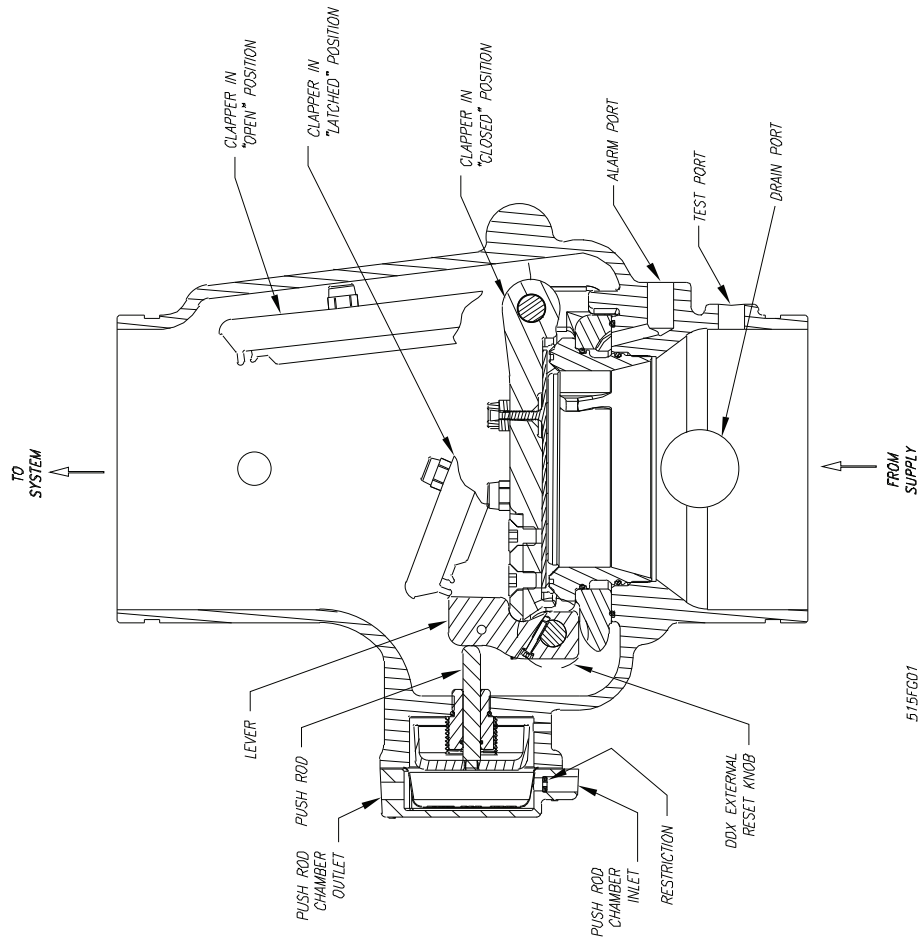

REAR VIEW OF MODEL
DDX VALVE

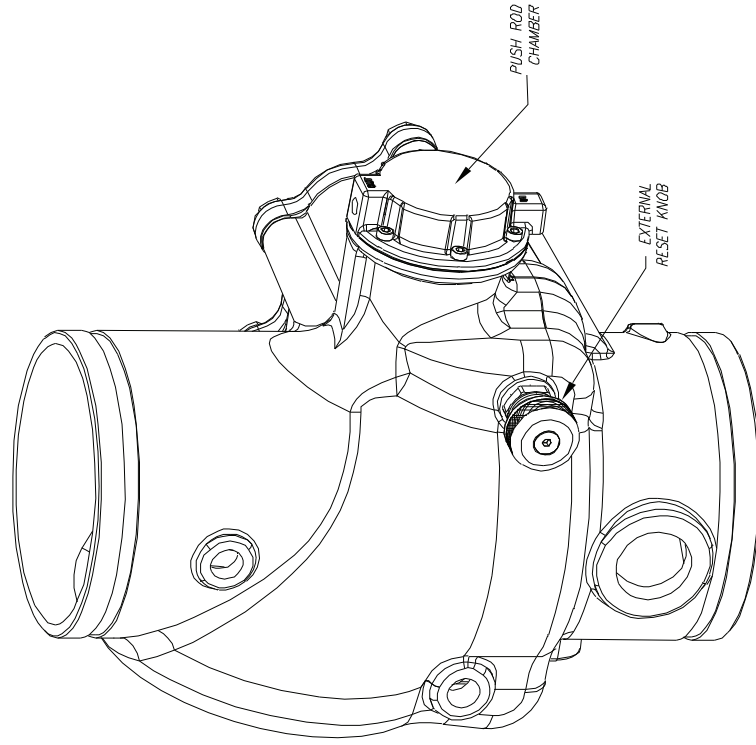

PUSH INWARD AND ROTATE KNOB CLOCKWISE TO RESET CLAPPER.
DO SO ONLY WHEN PUSH ROD CHAMBER IS VENTED.

Fig. 1

Single Interlock Electric Release Preaction Trim Parts List (Refer to Fig. 2)

ITEM NO.	PART NO.	DESCRIPTION	QTY.
1	6871020000	Psivalve, Solenoid, Parker (175 PSI)	1
	6871020020	Valve, Solenoid, Parker (250 PSI)	
2	6215053200	8" Ul/fm Butterfly Valve	1
3	6103080001	Assembly, Duluge Dry Valve	1
4	78653000	Assembly, Manual Emergency Station	1
5	78653004	Assembly, Valve Caution Station, 1/2"	1
6	98048015	Bushing, Reducer, 2" Spigot x 1" NPTF, PVC	1
7	98048022	Bushing, Reducer, 3/4" x 1/2", Galv.	1
8	98048025	Bushing, Reducer, 3/4" x 1/4", Galv.	1
9	98840147	Check Valve, 1/4" NPT, Poppet Type Inline	1
10	92056810	Connector, 3/8" Id Tube x 1/2" NPT	1
11	92056702	Connector, 3/8" Tubing x 1/4" NPT	2
12	92056704	Connector, Elbow, 3/8" Id Tube x 1/2" NPT	1
13	92056705	Connector, Elbow, 3/8" Id Tube x 1/4" NPT	1
14	7G05323200	Coupling, Rigid, 8"	2
15	98050004	Drain Cup, PVC	1
16	98174403	Ell, 1", Mall Iron, Galv.	1
17	98174405	Ell, 2", Mall Iron, Galv.	1
18	98174402	Ell, 3/4", Mall Iron, Galv.	1
19	96920912	Flex Line, 12"	1
20	98248000	Gauge, Air Pressure (0-80 PSI)	1
21	98248001	Gauge, Water Pressure (0-300 PSI)	2
22	98840172	Globe Valve, 1/4"	1
23	98840181	Horiz. Swing Check Valve, 1/2" NPT	1
24	91004288	Manifold, Supply, 8"	1
25	94616917	Nameplate, Single Interlock	1
26	98543222	Nipple, Steel, Galv., 1" x 3-1/2"	1
27	98543266	Nipple, Steel, Galv., 1" x 6"	1
28	98543213	Nipple, Steel, Galv., 1" x Close	1
29	98543223	Nipple, Steel, Galv., 1/2" x 1-1/2"	9
30	98543216	Nipple, Steel, Galv., 1/2" x 3-1/2"	2
31	98543209	Nipple, Steel, Galv., 1/2" x 2"	5
32	98543226	Nipple, Steel, Galv., 1/4" x 1-1/2"	1
33	98543225	Nipple, Steel, Galv., 1/4" x 2-1/2"	1
34	98543217	Nipple, Steel, Galv., 1/4" x 6"	2

ITEM NO.	PART NO.	DESCRIPTION	QTY.
35	98543262	Nipple, Steel, Galv., 2" x 3-1/2"	2
36	-----	-----	--
37	98543238	Nipple, Steel, Galv., 2" x Close	1
38	98543279	Nipple, Steel, Galv., 3/4" x Close	2
39	99080002	Pad-adhesive	1
40	98750003	Pipe Cross, 1/2", Galv.	1
41	98604406	Plug, Iron, Sq. Hd., 1/2"	1
42	98614403	Plug, Iron, Sq. Hd., 1/4"	4
43	98614401	Plug, Iron, Sq. Hd., 3/4"	2
44	98727607	Strainer, 1/4"	1
45	98840145	Swing Check Valve, 1" NPT	1
46	96606627	Tee, Glvn, 2" x 2" x 1"	1
47	96606607	Tee, Glvn., 1/2" x 1/2" x 1/4"	1
48	98761649	Tee, Glvn., 1/2" x 1/4" x 1/2"	2
49	98761651	Tee, Glvn., 1/2"	1
50	96606612	Tee, Glvn., 3/4" x 1/2" x 1/2"	1
51	96606601	Tee, Glvn., 3/4"	1
52	89141112	Tie, Retaining	9
53	98815200	Union, 1/2", Iron, G.J., Galv.	2
54	98840160	Valve, 3-way, 1/4"	3
55	98840100	Valve, Angle, 2"	1
56	78653100	Valve, Ball Drip, 1/2"	1
57	98840117	Valve, Ball, 1/4" NPTF x 1/4" NPTM	1
58	98840187	Valve, Check, 1/4" NPTF x 1/4" NPTM	1
59	98840171	Valve, Globe, 1/2"	1
60	96686722	Tubing, Copper, 3/8" O.D. x 2 Ft.	1
61	96686754	Tubing, PVC, 3/8" I.D. x 6 Ft.	1

System Operation

To fully operate a Single Interlock Preaction System, two independent events must coexist before water flow will occur. One electrical detector (two detectors in a cross-zoned system) must activate and a sprinkler head must open. Operation of either one of these items will only cause an alarm to annunciate, but will not cause water to discharge from the sprinkler system piping.

When set correctly for service, the Model DDX Deluge Valve is hydraulically established to withhold the supply water from the sprinkler system piping. The Reliable Model DDX Deluge Valve is shown in both closed and open positions in Fig. 1. In the closed position, the supply pressure acts on the underside of the clapper and also on the push rod through the push rod chamber's inlet restriction. The resultant force due to the supply pressure acting on the push rod is multiplied by the mechanical advantage of the lever and is more than sufficient to hold the clapper closed against normal supply pressure surges.

When a fire is detected, the energized solenoid valve vents the push rod chamber to atmosphere through the chamber's outlet. Since the pressure cannot be replenished through the inlet restriction as rapidly as it is vented, the pushrod chamber pressure falls instantaneously. When the pushrod chamber pressure approaches approximately one-third of the supply pressure, the upward force of the supply pressure acting beneath the clapper over comes the lever-applied force thereby opening the clapper.

Once the clapper has opened, the lever acts as a latch, preventing the clapper from returning to the closed position. Water from the supply flows through the Deluge Valve into the system piping. Water also flows through the Deluge Valve alarm outlet to the alarm devices.

After system shutdown, resetting the Model DDX Deluge Valve is quite simple. Doing so only requires pushing in and turning the reset knob at the rear of the valve (see Fig. 1). The external reset feature of the Model DDX Deluge Valve provides a means for simple, economical system testing, which is one essential facet of a good maintenance program. The external reset feature does not, however, eliminate another important facet of good maintenance, namely, periodic cleaning and inspection of the internal valve parts.

In the event that water builds up inside the valve due to condensate from the air supply system or water left inside from valve system testing, a drain is available for venting. After closing the main supply valve, a small valve over the drain cup can be opened slightly until the water inside the valve body and the main pipe column has drained. See the section titled "Draining Excess/ Condensate Water From System" in this bulletin for the detailed procedure.

The Model B Manual Emergency Station (see Fig. 3) is also included in the Reliable Single Interlock Preaction System trim set. It consists of an aluminum nameplate mechanically attached to a ball valve. The valve handle in its OFF position is guarded against accidental turning to the ON position (and system discharge) by a nylon cable tie provided with each trim kit. The cable tie is inserted,

as shown in Fig. 3, after the system has been restored for operation. The nylon cable tie is designed to allow, in case of an emergency, forceful turning of the valve handle to the ON position. As an alternative to the Model B Hydraulic Manual Emergency Station, the Model A Hydraulic Manual Emergency Pull Box (see Reliable Bulletin 506) is also available and can be provided as an option.

Whenever ambient temperature conditions are high, the water temperature in the Model DDX Deluge Valve's push-rod chamber could possibly increase, thereby increasing the pressure in the chamber to values exceeding the rated pressure of the system. In an indoor installation where standard room temperatures are exceeded, a pressure relief kit may be needed. Pressure relief kit, P/N 6503050001, can be installed into the pushrod chamber's releasing line to limit the pressure to 175 psi (12,1 bar).

Pressurizing Line Connection

The water supply for the push-rod chamber must be provided by connection of its inlet pressurizing line to the water supply piping. Pressurizing lines for multiple Model DDX Deluge Valve push-rod chambers must never be manifolded together, having only a single tap on the water supply piping. Each Model DDX Deluge Valve must have its own push-rod chamber pressurizing line connection. This connection must be made on the supply side of the main water supply control valve. This can be accomplished by:

a. Using a tapped connection directly below or next to the main water supply control valve using a welded outlet or the appropriate mechanical fittings. A grooved-end outlet coupling is one way to achieve this; or

b. Using a water supply control valve that has an available threaded (NPT) supply-side tap design to allow for a direct water supply connection to the Model DDX Deluge Valve's push-rod chamber.

Caution: Reliable's DDX valve is designed with an inlet restriction built into the pushrod chamber. It is important not to introduce additional restrictions into the direct water supply connection or the discharge from the pushrod chamber by installing additional valves or improperly installing the copper lines used in the trim of the valve.

Hydrostatic Testing of DDX Valves and DDX Systems

As required by NFPA 13, fire sprinkler systems with working pressures up to and including 150 psi are to be hydrostatically tested at a water pressure of 200 psi and maintain that pressure without loss for two hours. Fire sprinkler systems with working pressures above 150 psi are required to be hydrostatically tested at 50 psi above the system working pressure and maintain that pressure without loss for two hours. In addition to the hydrostatic tests described above, dry pipe and double interlock preaction systems require an additional low pressure air test.

MODEL B HYDRAULIC MANUAL EMERGENCY STATION

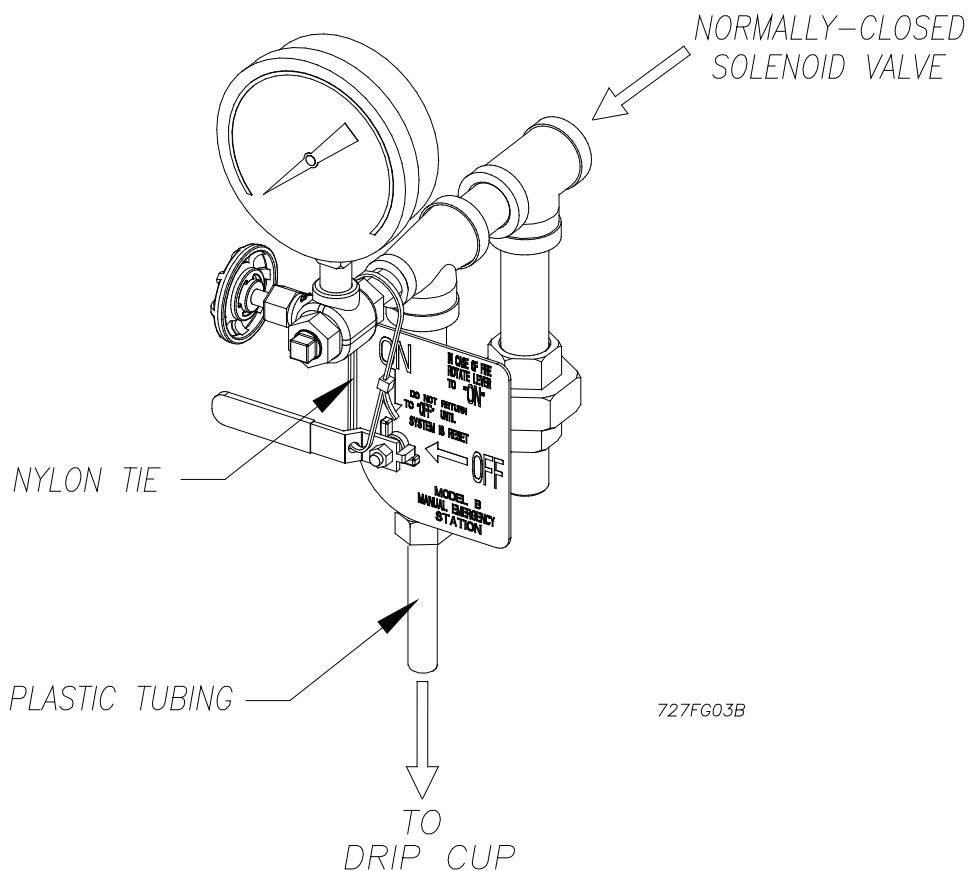

Fig. 3

In some cases, hydrostatic testing (in accordance with the NFPA 13 requirements noted above) will result in pressures that exceed the working pressure of the valve and trim kit for the two-hour test period. The valve and applicable trim kit have been tested, approved and listed under these conditions and as such, hydrostatic testing in accordance with NFPA 13 is acceptable. In addition, the clapper can remain in the closed position and the trim kit need not be isolated, as each has been designed to withstand hydrostatic testing as required by NFPA 13.

Hydrostatically testing the valve and trim to pressures higher than their rating is limited to the hydrostatic test as referenced by NFPA13. It does not address the occurrence(s) of a "water hammer" effect, which can indeed damage the valve. A "water hammer" in the water supply piping of the valve can create pressures in excess of the rated pressure and should be avoided by all necessary means. This condition may be created from improper fire pump settings, underground construction work, or an improper venting of trapped air in the water supply piping.

System Design Considerations

The automatic sprinklers, air compressor, releasing devices, electric releasing control equipment, fire detection devices, manual pull stations, and signaling devices which are utilized with the Single Interlock Preaction System must be UL or ULC Listed or FM Approved, as applicable.

The Deluge Valve, and all interconnecting piping must be located in a readily visible and accessible location and in an area that can be maintained at a minimum temperature of 40°F (4°C). **Note:** Heat tracing is not permitted.

Pendent sprinklers, other than dry pendants, used on preaction systems shall be installed on return bends per NFPA 13.

The solenoid valve is operated and supervised by the electrical releasing/control panel. Details on the electrical portion of this system can be found in Reliable Bulletin 700, "Special Hazards & Special Systems".

SINGLE INTERLOCK PREACTION SYSTEM ELECTRICAL CONNECTIONS

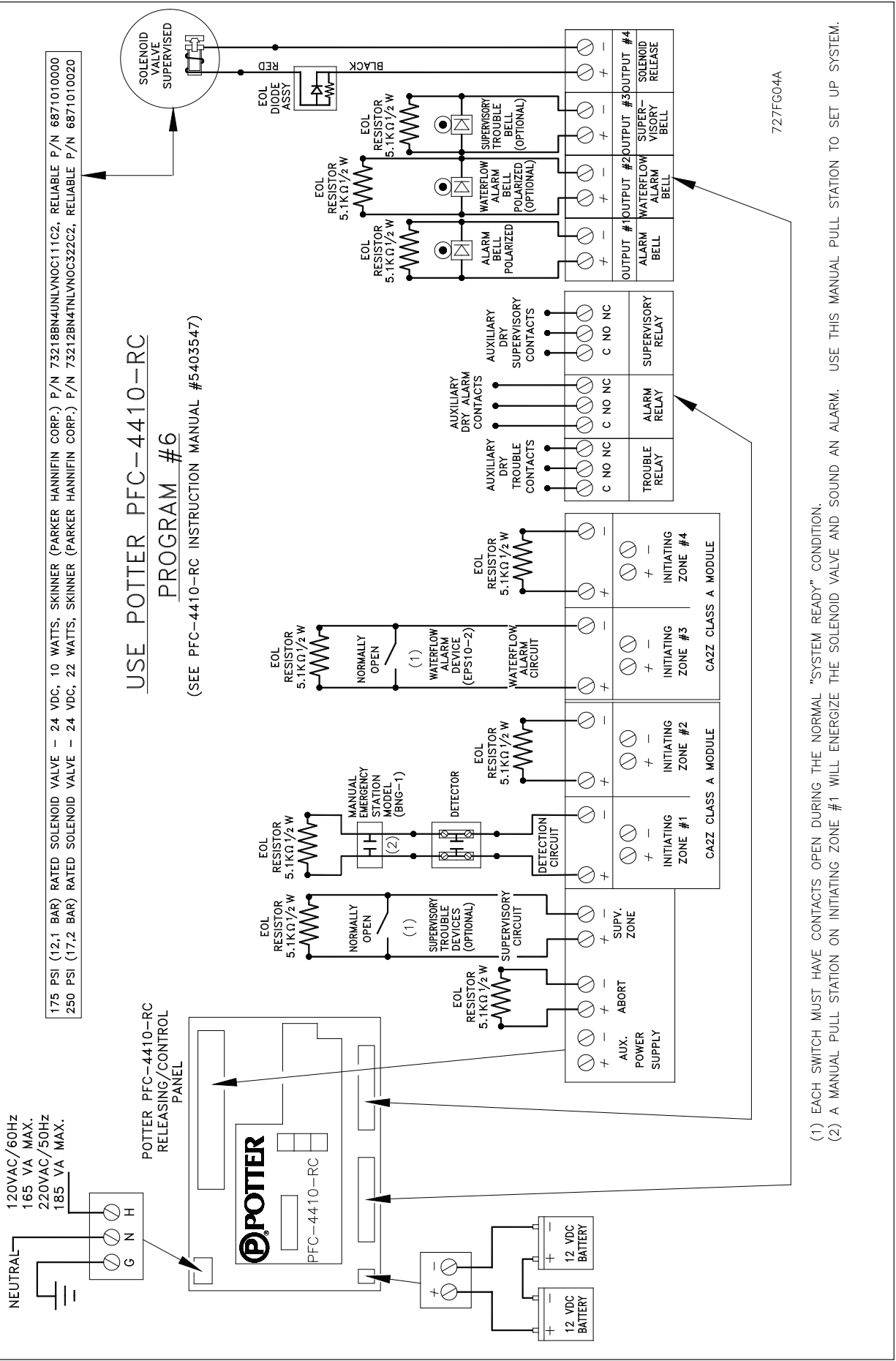

- (1) EACH SWITCH MUST HAVE CONTACTS OPEN DURING THE NORMAL "SYSTEM READY" CONDITION.
- (2) A MANUAL PULL STATION ON INITIATING ZONE #1 WILL ENERGIZE THE SOLENOID VALVE AND SOUND AN ALARM. USE THIS MANUAL PULL STATION TO SET UP SYSTEM.

Fig. 4

System Air Pressure Requirements

A Reliable Model B Air Compressor Panel or Model C Pressure Maintenance Device is used to maintain the system pneumatic pressure at approximately 35 oz/in² (2.2 psi or 0,2 bar). The air compressor panel contains an integral low air pressure warning light, while the pressure maintenance device requires a separate annunciating device to be connected to the low pressure switch. The switch is factory set to transfer contacts when the supervisory pressure falls below approximately 11 oz/in² (0.7 psi or 0,05 bar). The pressure maintenance device is a supervisory pneumatic supply for use where a clean, dependable and continuous compressed air or dry nitrogen gas source is available in the 40 to 100 psi (2,8 to 6,9 bar) pressure range.

In some circumstances, such as when dry sprinklers are being used in a preaction system, it may be desirable to supervise the preaction system at air pressures higher than 2 psi. For such cases, Reliable recommends the use of an A-2 air maintenance device with either a System Sensor EPS-10 or EPS-40 low air pressure switch. Supervising air pressure may be between 7psi and 20 psi, depending on which low air pressure switch is being utilized.

System Electrical Requirements

All releasing, alarm and detection devices in the Single Interlock Preaction System are supervised by the Potter PFC-4410-RC Releasing Control Panel. Connect these devices as shown in Fig.4. The Releasing/ Control Panel should be set to use Program #6 (See Potter Instruction Manual #5403550).

The power supply, the standby emergency power supply, battery charger, and the rectifier circuitry are all contained within the Potter PFC-4410-RC Releasing Control Panel. The solenoid valve is operated and supervised by the Potter PFC-4410-RC Releasing Control Panel. Potter PFC-4410-RC Releasing Control Panel requires 120 VAC. Batteries that provide ninety hours of standby power are required for Factory Mutual Approved systems.

For additional information and detailed wiring diagrams, refer to Reliable Bulletin 700, "Special Hazards & Special Systems". These diagrams describe single area, single area cross-zoned, and two area systems.

Caution: Repairs or disassembly of the solenoid valve should only be done by a trained technician. An improperly repaired or partially assembled solenoid valve could result in failure of the valve to operate.

Single Interlock Preaction System– Electric Release Trim Engineering Specifications

General Description

Preaction system shall be a Single Interlock Preaction System utilizing an 8" (200mm) Reliable Model DDX Deluge Valve. Deluge valve shall be a [8" (200mm)] [cULus Listed][Factory Mutual Approved] hydraulically operated, differential latching clapper-type valve. Deluge valve construction shall be of lightweight, ductile-iron construction with "screw in" stainless steel seat and clapper assembly. Stainless steel seat shall have O-ring seals to resist leak-

age and corrosion. Clapper facing shall be pressure actuated, providing a limited compression seat for the sealing force between the clapper rubber facing and the valve seat. Deluge valve shall have an external reset knob for resetting the clapper without requiring the removal of the valve face plate. Push-rod chamber design shall consist of a stainless steel piston/ push-rod and spring assembly with diaphragm seal secured to the casting through a push-rod guide constructed of a synthetic engineering plastic to resist corrosion. Casting shall have a bleeder hole located on the pushrod chamber for air/water leakage indication. Trip ratio shall be approximately a 3:1 force differential. Deluge valve shall be of the straight through design to minimize friction loss. Deluge valve shall be activated by [hydraulic wet- pilot][low pressure, pneumatic dry-pilot][electric] actuation trim. Inlet restriction orifice shall be factory installed into the inlet port of the deluge valve pushrod cover plate and not be a separate part of the deluge valve trim. End connection style to be [8" (200mm)] grooved inlet and grooved outlet, per ANSI/AWWA C606. Deluge valve shall have a rated working pressure of 250 psi (17,2bar) and shall be factory hydrostatic tested at 500 psi (34,5 bar).

Deluge valve to be [8" (200mm)] Reliable Model DDX Deluge Valve (Bulletin 513).

Preaction electric release trim shall consist of galvanized and brass components specifically listed/approved with the deluge valve. Deluge valve releasing device shall be an electrical two-way, normally closed, pilot operated solenoid valve [cULus Listed] [FMAApproved] for its intended use. The solenoid valve shall be constructed of a brass body with stainless steel sleeve tube, springs, stop and plunger, and with ½" female NPT end connections. Solenoid valve shall have a maximum working pressure of [175 psi (12,1 bar)] [250 psi (17,2 bar)] and maximum ambient temperature rating of 150°F (66°C). Power consumption of integrated coil shall be limited to [10 watts (175 psi (12,1 bar)) Rated]

[22 watts (250 psi (17,2 bar)) Rated] and require 24 VDC from a releasing/control panel listed for such service. Solenoid valve shall be a Skinner ½" normally-closed solenoid valve, [Model 73218BN4UNLVNOC111C2 (175 psi (12,1 bar)) Rated]. [Model 73212BN4TNLVNOC322C2 (250 PSI (17,2 bar)) Rated].

Supervisory Air Supply Options

Owner's Air supply

Single interlock preaction system air pressure shall utilize low supervisory air pressure. Air supply shall be provided by an owner supplied air system in conjunction with a [cULus Listed] [FM Approved] automatic low air pressure maintenance device. The pressure maintenance device trim assembly shall consist of a field adjustable, low pressure line regulator, air filter assembly, low air pressure switch, pressure gauge and check valve. Regulator shall be capable of receiving 40 to 100 psi (2,8 to 6,9 bar) inlet pressure and provide approximately 2 psi (0,14 bar) outlet supervisory pressure.

The pressure switch shall have a SPDT contact rated at 15 A @ 125/250 VAC, and 10 A @ 12 VDC. Pressure switch shall transfer contacts when the supervisory pressure falls below approximately 0.5 psi (0,03 bar).

Low Pressure Air Compressor Panel

Precision system supervisory air supply shall be a [cULus Listed] [FM Approved] self-contained, low pressure air compressor panel containing a 1/16 hp air compressor, DPDT relay for remote supervisory annunciation, low pressure warning light, pressure gauge, and low pressure alarm switch. Pressure switch shall control the compressor, providing a maximum operating supervisory pressure of 2 psi (0,14 bar), and a low-pressure supervisory alarm at approximately 0.5 psi (0,03 bar). Power requirements shall be 120 VAC/60 Hz.

Optional System Accessories

System Control Valve

Precision system control valve shall be a slow close, [cULus Listed] [FM Approved] indicating butterfly type valve with a pre-wired supervisory tamper switch assembly. The valve shall be rated for a working pressure of [300 psi (20,7 bar)]. System control valve shall be a [8" (200mm)] Nibco GD-4765-8N Butterfly Valve.

Detection System

To initiate actuation of the precision system's deluge valve, a supplemental electric detection system shall be provided

[Insert applicable product specification]

Releasing/Control Panel

A releasing/control panel shall be used to operate the precision system. The releasing/control panel shall be a conventional, microprocessor-controlled panel containing two initiating device circuits, and waterflow and supervisory inputs. Output circuits shall include alarm, waterflow, supervisory, and releasing circuits. The releasing/control panel shall be capable of providing any of the following desired modes of operation: single hazard, two zone; single hazard, cross-zoned; dual hazard, combined release; and dual hazard, split release (two area). Releasing/control panel shall be equipped with a local tone alarm to announce loss of AC power, system trouble, circuit trouble, and low auxiliary DC power supply. Panel shall be [cULus Listed] [FM Approved] and be capable of providing power for compatible detectors and auxiliary devices used. Audible alarms shall be able to be silenced at releasing panel. Auxiliary DC power supply shall consist of (2) 12-volt lead acid batteries of the same ampere-hour rating, providing [60 hours – cULus Listed] [90 hours – FM Approved]. Dry contacts shall be provided for remote annunciation of alarm, trouble, and supervisory panel signals. Main power supply to be a dedicated a 120 VAC / 60 Hz circuit.

Waterflow Alarm Pressure Switch

Alarm pressure switch shall be provided to indicate water flow and provide a water flow alarm. Pressure switch shall be [cULus Listed] [FM Approved] and of the bellows activated type enclosed in a weatherproof, 4x, NEMA 4-

rated enclosure incorporating tamper-resistant screws. There shall be two sets of SPDT (Form C) contacts rated at 10.0 A @ 125/250 VAC and 2.5 A @ 6/12/24 VDC. The pressure switch shall have a maximum service pressure rating of 250 psi (17,2 bar) and shall be factory adjusted to operate at a pressure of 4 to 8 psi (0,27 to 0,55 bar) with adjustment up to 20 psi (1,3 bar). Switch shall be provided with a 1/2" NPT male pressure connection. Waterflow alarm pressure switch shall be System Sensor EPS10-2.

Technical Data

Reliable Wet Pilot Line Single Interlock Precision Systems, with associated trim, size 8" (200mm) is rated for use at minimum water supply pressure of 20 psi (1,4 bar) and maximum supply pressure of 250 psi (17,2 bar). Water supplied to the inlet of the valve and to the pushrod chamber must be maintained between 40°F (4°C) and 140°F (60°C).

The following list of technical bulletins pertains to valves and devices that may be used in this precision system:

Deluge Valve	Reliable 514/515
Hydraulic Emergency Station (Model A)	Reliable 506
Solenoid Valve	Reliable 700
Mechanical Sprinkler Alarm	Reliable 612/613
Pressure Maintenance Device	Reliable 252
Air Compressor Panel (Models B & C)	Reliable 252
Releasing/Control Panel	Potter #5403550
Electric Emergency Station	Reliable 700
Thermal Smoke Detectors	Reliable 722
Fire Alarm Devices	Reliable 700
Waterflow Pressure Alarm Switch	System Sensor A05-0176

Model DDX Valve Description

1. Rated working pressure: Valve & System - 250 psi (17.2 bar).
2. Factory tested to a hydrostatic pressure of 500 psi (34,5 bar). (Valve only)
3. End and trim connections:
 - ANSI/AWWA C606 grooved inlet and outlet

Groove Dimension			
Outlet Diameter	Groove Diameter	Groove Width	Outlet Face to Groove
8.625" (219mm)	8.441" (214mm)	7/16" (11mm)	3/4" (19mm)

- Threaded openings Per ANSI B 2.1
 - Valve Exterior's Color: Black
4. Face to face dimensions:
 - 19 3/8" (492 mm)
 5. Shipping weight:
 - 148 lbs (67.3 kg)

6. Friction loss (Expressed in equivalent length of Schedule 40 pipe, based on Hazen & Williams formula with C=120
 - 53.5 ft (16.31 m)
7. Installation position: Vertical

Maintenance

Reliable Single Interlock Preaction Systems and associated equipment shall periodically be given a thorough inspection and test. NFPA 25, Inspection, Testing and Maintenance of Water Based Fire Protection Systems, provides minimum maintenance requirements. System components shall be tested, operated, cleaned, and inspected at least annually, and parts replaced as required.

Resetting the Single Interlock Preaction System

Refer to Figs. 2, 5, and 6.

1. Close the main valve controlling water supply (Fig. 6) to the Deluge Valve and close off the air supply to the sprinkler system.
2. Close the pushrod chamber supply valve; valve A (Fig. 6).
3. Open the main drain valve, valve B (Fig. 6), and drain system.
4. Open all drain valves and vents at low points throughout the system, closing them when flow of water has stopped. Open valve D (Fig. 6).

Note: The above steps accomplish the relieving of pressure in the pushrod chamber of the Deluge Valve.

5. With valve G (Fig. 6) open, push in the plunger of ball drip valve, valve E (Fig. 6), to force the ball from its seat, and drain any water in the alarm line.
6. With the Model B Manual Emergency Station, valve D (Fig. 6), open, push in and rotate the Deluge Valve's external reset knob (#14, Fig. 5) clockwise until you hear a distinct clicking noise, indicating that the clapper has closed. Note: The reset knob can be rotated only after pressure in the pushrod chamber is vented to atmospheric conditions (0 psig).
7. Inspect and replace any portion of the sprinkler system subjected to fire conditions.
8. Open valve A (Fig. 6) and allow water to fill the Deluge Valve's pushrod chamber. Close valve D (Fig. 6).
9. Bleed any air from the actuation piping by energizing the solenoid valve. This is done by operating a detector or an electric manual emergency station. While water is flowing through the solenoid valve, cause it to close. Refer to Bulletin 700, "Special Hazards & Special Systems" for details.

Note: All detection devices must be reset before the releasing/control panel can be reset.

10. Close valve G (Fig. 6) to fill the system with air. Open the valve once air pressure in the sprinkler system is restored.

11. Open valve A (Fig. 6). Open slightly the main valve controlling water supply (Fig. 6) to the Model DDX Deluge Valve, closing drain valve B (Fig. 6) when water flows. Observe if water leaks through the ball drip valve, valve E (Fig. 6), into the drip cup, J (Fig. 6). If no leak occurs, the Deluge Valve's clapper is sealed. Open slowly, and verify that the main valve controlling water supply is fully opened and properly monitored.
12. Verify that valve A (Fig. 6) and valve G (Fig. 6) are open.
13. Secure the handle of the Model B Manual Emergency Station, valve D (Fig. 6), in the OFF position with a nylon tie (#52, Fig. 2).

Inspection and Testing

Refer to Figs. 2, 5, and 6.

1. **Water supply** — be sure the valve(s) controlling water supply to the Deluge Valve are opened fully and properly monitored.
2. **Alarm line** — be sure that valve G (Fig. 6) is opened and remains in this position.
3. **Other trimming valves** — check that valve A (Fig. 6) is open as well as all of the pressure gauge's ¼" 3-way valves. Valves D, F, and H (Fig. 6) should be closed.
4. **Ball drip valve E (Fig. 6)** — make sure valve G (Fig. 6) is open. Push in on the plunger to be sure the ball check is off its seat. If no water appears, the Deluge Valve's water seat is tight. Inspect the bleed hole (see Fig. 5) on the underside of the push rod chamber for leakage.
5. **System pneumatic pressure** — check that system air pressure is approximately 35 oz/in² (2.2 psi or 0,2 bar). Check the pressure maintenance device for leakage and proper pressure.
6. **Releasing device** — check outlet of the releasing device (i.e., solenoid valve or the Model B Manual Emergency Station, valve D (Fig. 6)) for leakage. Also verify that tubing drain lines from releasing devices are not pinched or crushed which could prevent proper releasing of the Deluge Valve.
7. **Testing alarms** — make sure valve G (Fig. 6) is open. Open valve F (Fig. 6) permitting water from the supply to flow to the electric sprinkler alarm switch and to the mechanical sprinkler alarm (water motor). After testing, close this valve securely. Push in on the plunger of ball drip valve E (Fig. 6) until all of the water has drained from the alarm line.
8. **Operational test** — Open the Model B Manual Emergency Station, valve D (Fig. 6), or operate by electrical actuation (refer to Bulletin 700, "Special Hazards & Special Systems" for details). Note: An operational test will cause the Deluge Valve to open and flow water into the sprinkler system.
9. Secure Model B Manual Emergency Station, valve D (Fig. 6), in the OFF position with a nylon tie (#52, Fig. 2) after the Deluge Valve is reset.

MODEL DDX VALVE 8"(200MM)

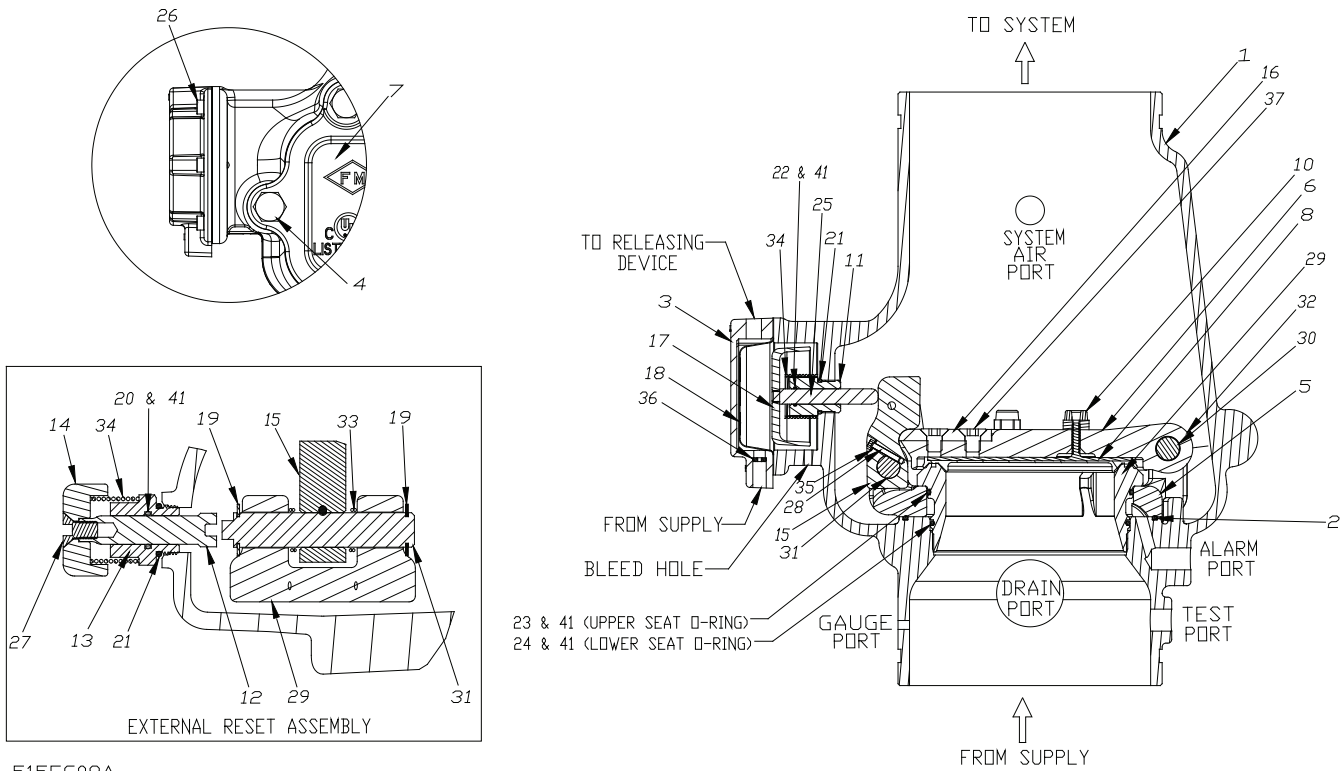

515FG08A

Fig. 5

Model DDX 8" (200mm) Deluge Valves Parts List (Refer to Fig. 5)

ITEM NO.	PART NUMBER	PART DESCRIPTION	NO. REQ'D
1	91006028	Body	1
2	95406414	O-Ring, (266)	1
3	92126006	Cover, Pushrod	1
4	95606110	Screw, Hex Cap, 5/8-11 x 2", ZN PLTD, Grade A	8
5	91306018	Mounting Ring	1
6	91916008	Clapper	1
7	92116068	Cover, Access	1
8	93416008	Seal Assembly	1
9	93706008	Gasket, Access Cover (Not Shown)	1
10	93722000	Bumpstop Assembly	3
11	93916006	Pushrod Guide	1
12	93916066	Shaft, Reset	1
13	94106066	Housing, Reset	1
14	94356006	Knob, Reset	1
15	94506008	Lever	1
16	95006410	Striker, Lever/Clapper	1
17	95106006	Piston	1
18	95276006	Diaphragm	1
19	95316408	Clip, Retaining, 3/4" Shaft, SS	4
20	95406007	O-Ring, (114)	1
21	95406024	O-Ring, (912)	2
22	95406407	O-Ring, (014)	1

ITEM NO.	PART NUMBER	PART DESCRIPTION	NO. REQ'D
23	95406413	O-Ring, (260)	1
24	95406412	O-Ring, (259)	1
25	95506006	Pushrod	1
26	95606114	Screw, Socket Head, 1/4-20 x 5/8"	6
27	95606127	Screw, Socket Cap, Flat Head, 3/8-16 x 3/4"	1
28	95606130	Screw, Socket Head, #10-23 x 1", SS	1
29	96016008	Seat	1
30	96206008	Pin, Hinge	1
31	96216008	Pin, Lever	1
32	96310008	Spacer, Clapper	2
33	96406008	Spring, Lever	1
34	96406906	Spring, DDX	2
35	96906111	Washer, Spring Lock, #10, SS	1
36	94206406	Inlet Orifice	1
37	95606135	Screw, Socket Cap, Flat Head, 1/2-13 x 3/4", SS	2
38	94616921	Label, Caution, Knob (Not Shown)	1
39	91556922	Ball Chain, 1/8" (Not Shown) (Length in Inches)	6
40	91556923	Clamping Link, Ball Chain, (Not Shown)	1
41	85000050	O-ring Grease, DuPont™ Krytox® GPL-201	A/R

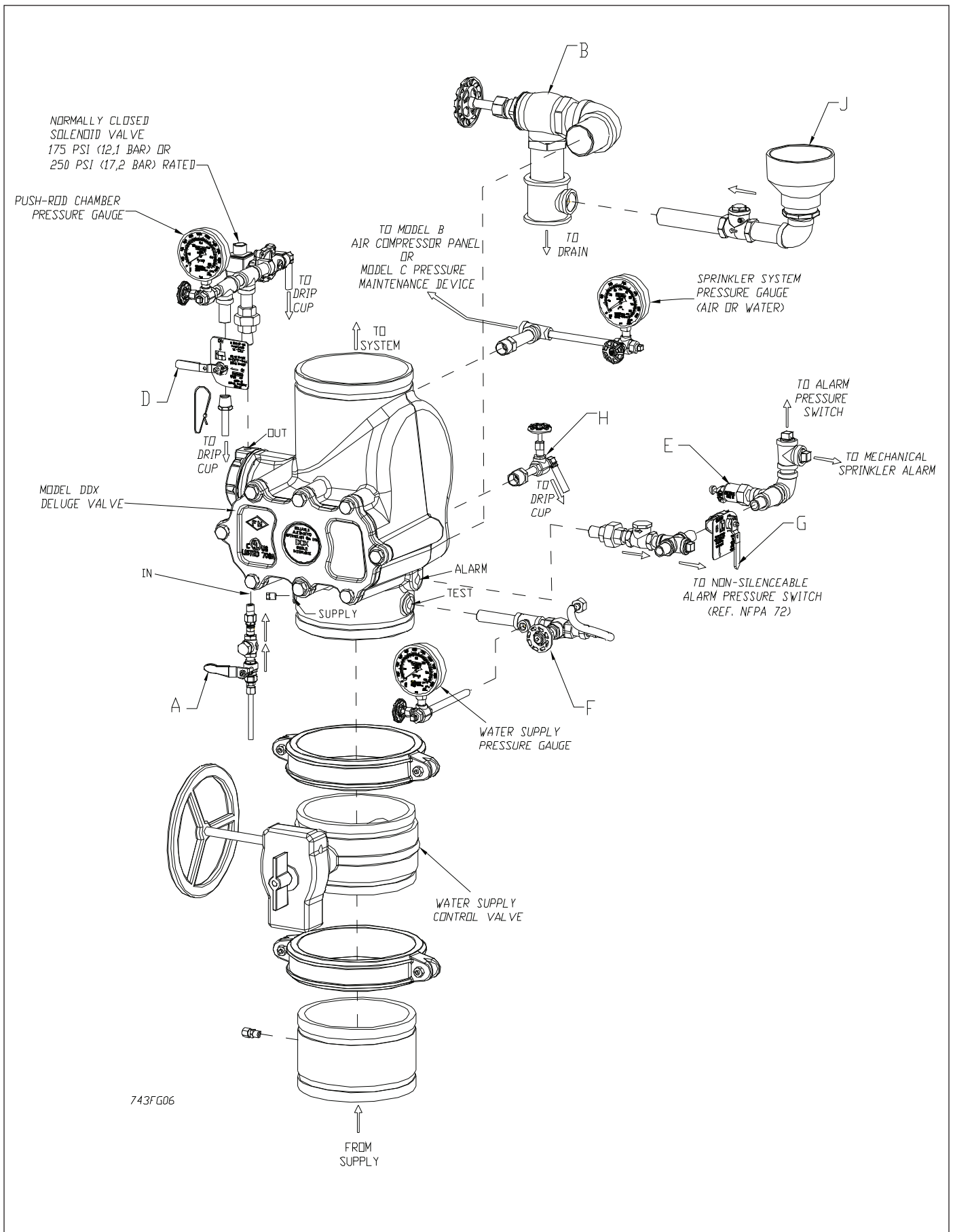

Fig. 6

Testing the Model DDX Deluge Valve

Without Flowing Water

Refer to Fig. 6

1. Close the valve controlling water supply to Deluge Valve and open the main drain valve B.
2. Verify that valve A is open, allowing water to enter the push rod chamber.
3. Operate detection system – energize the solenoid valve by operating a detector (refer to Bulletin 700, “Special Hazards & Special Systems” for details).
4. Operation of the detection system will result in a sudden drop of water pressure in the pushrod chamber.
5. Reset detection system — reverse operations performed in step three above and then proceed according to the directions listed in the “Resetting the Single Interlock Preaction System” section of this bulletin for resetting the Deluge Valve.

Draining Excess/Condensate Water From System

Refer to Fig. 6

1. Close the main valve controlling water supply to Deluge Valve. Also close valve A and open main drain valve B.
2. Open condensate drain valve H until all water has drained. Close valve H. **Note:** Be sure not to keep valve H open for an extended period of time because that will cause enough system air to bleed off thereby causing an undesirable activation of a trouble-annunciating device.
3. Close main drain valve B. If system contains pressurized air, allow air pressure to come back up to specification. Open valve A first, and then open the main valve controlling the water supply to the Deluge Valve.

Maintenance Procedures - Model DDX

Deluge Valve

Refer to Figs. 2, 5, & 6.

1. Mechanical sprinkler alarm (water motor—not shown) not operating:

This is most likely caused by a clogged screen in the strainer of the water motor. Proceed as follows: Remove plug from the strainer. Remove and clean the screen. Replace the screen and the plug, and then tighten securely (Ref. Bulletin 613).

2. Leakage out of the ball drip valve E (Fig. 6).

a. Water leakage due to a water column above the Deluge Valve’s clapper:

This condition can be caused by leakage past the system side of the Model DDX Deluge Valve’s seal faceplate subassembly (#8, Fig. 5). Be sure that this surface is free of any type of debris. To eliminate leakage due to a water column, refer to the section in this bulletin marked “Draining Excess/Condensate Water From System”. If the problem continues proceed to the following section.

b. Leakage, air or water from the ball drip valve, E Fig. 6)

If system air is leaking out the ball drip valve, the problem is either damage to the airside of the Model DDX Deluge Valve’s seal assembly (#8, Fig. 5), seat (#29, Fig. 5) mounting ring O-ring (#2, Fig. 5), or the upper seat O-ring (#23, Fig. 5). If supply water is leaking out the ball drip valve, the problem could be caused by damage to the Model DDX Deluge Valve’s seal assembly (#8, Fig. 5), seat (#29, Fig. 5), or lower seat O-ring (#24, Fig. 5). The following section provides instructions to correct both conditions:

A. Shut down the valve controlling the water supply to the Deluge Valve and open the 2” main drain valve B (Fig. 6). Open the water column drain valve H (Fig. 6). Close the pushrod chamber supply valve A (Fig. 6) and open the Model B Manual Emergency Station D (Fig. 6).

B. Remove the Deluge Valve’s front (handhold) cover (#7, Fig. 5) and inspect the seat (#29, Fig. 5), clapper (#6, Fig. 5), and seal assembly (#8, Fig. 5) for damage.

If inspection indicates damage to the seal assembly (#8, Fig. 5), replace as follows:

Remove the bumpstop nuts (#10, Fig. 5) and remove the seal assembly (#8, Fig. 5). Install a new seal assembly (#8, Fig. 5) and thread the bumpstop nuts (#10, Fig. 5) onto the threaded stud of the seal assembly (#8, Fig. 5) and tighten finger tight plus ¼ to ½ turn. If inspection indicates damage to the clapper (#6, Fig. 8) only, then the clapper sub-assembly can be removed as follows:

At the rear of the valve, disconnect the water column drain trim section starting with the elbow connector (#13, Fig. 2). Then remove the ¼” globe valve (#22, Fig. 2), followed by the ¾” x ¼” reducing bushing (#8, Fig. 2). Remove the retaining ring (water column drain line side) from the clapper hinge pin (#30, Fig. 5) and push this pin through the handhold cover. Remove the clapper subassembly. Replace the seal assembly (#8 Fig. 5) as described previously. Inspect the clapper (#6, Fig. 5) visually before reinstalling. Reinstall in the reverse order making sure the clapper spacers are in their proper position. If the seat (#29, Fig. 5) is damaged or it is suspected that the leakage is through the lower O-ring (#24, Fig. 5), the seat-clapper subassembly is easily removed as a unit as follows:

Using Reliable P/N 6881608000 Seat Wrench, remove the seat by unscrewing. This will loosen the seat-clapper-mounting ring subassembly. Reach into the valve and grasp the seat and remove it from the valve. Then remove the clapper-mounting ring subassembly from the valve. Visually examine all components of the seat-clapper-mounting ring sub-assembly replacing any component that appears damaged. New O-rings (#2, #23 & #24, Fig. 5) should always be used for reassembly.

Reassembly:

Clean the bore of the valve body. Lubricate the bore with O-ring grease. Lubricate and install the O-rings (#23 & #24, Fig. 5) onto the seat and O-ring (#2, Fig. 5) into the body (#1, Fig. 5). Insert the clapper-mounting ring sub-assembly into the handhold opening of the Deluge Valve. Align the mounting ring so that the Lever (#15, Fig. 5) is near the pushrod (#25, Fig. 5) and the mounting ring (#5, Fig. 5) "ears" are between the tabs of the valve body (#1, Fig. 5). Insert the seat into the body (#1 Fig. 5) through the clapper-mounting ring assembly. Start to tread the seat (#29, Fig. 5) into the body by hand, then tighten until the seat (#29, Fig. 5) with seat wrench 6881608000 until it bottoms out on the mounting ring (#5, Fig. 5). Verify that the seat-clapper-mounting ring sub-assembly is in the fully down position between the tabs of the body, and check to see that the lever (#15, Fig. 5) lines up with the push rod (#25, Fig. 5). Loosen and reassemble if necessary. Reassemble the hand hold cover (#7, Fig. 5) and set up the Model DDX Deluge Valve as per the section "Resetting Model DDX Deluge Valve Systems."

3. Leakage out of the push rod chamber vent hole:

A small bleed hole is located on the underside of the pushrod chamber (see Fig. 5). If there is air or water leakage coming out of this hole, do the following:

- a. Shut down the valve controlling water supply to the Deluge Valve. Relieve the inlet pressure by opening the 2" drain valve B (Fig. 6). Close the valve A (Fig. 6) that supplies water to the pushrod chamber, and open the Model B Manual Emergency Station, valve D (Fig. 6).
- b. Remove the trim at the unions nearest to the push rod chamber cover (#3, Fig. 5).
- c. Take the push rod chamber cover (#3, Fig. 5) off by removing the six retaining screws (#26, Fig. 5).

CONDITION ONE (Water coming out of the bleed hole):

Water coming out of the bleed hole is caused by a leaking diaphragm (#18, Fig. 5). Visually inspect the pushrod chamber cover (#3, Fig. 5) and piston (#17, Fig. 5) to determine what could have damaged the diaphragm and correct. Install a new diaphragm. **NOTE:** The diaphragm has two different surfaces; it is not bi-directional. It will fail if installed backwards! Roll the diaphragm so that the smooth surface (the pressure side) conforms to the inside of the push rod chamber cover and reassemble the six retaining screws (#26, Fig. 5) with an installation torque of 15 foot-pounds. Set up the Model DDX Deluge Valve as per the section "Resetting the Single Interlock Preaction System."

CONDITION TWO (System Air coming out of the bleed hole):

System air coming out of the bleed hole is caused by a defective O-ring assembled to the pushrod guide (#11, Fig. 5). Remove the piston-push rod subassembly, push rod spring (#34, Fig. 5), and push rod guide (#11, Fig. 5). Verify by hand turning, that the push rod cannot be unscrewed from the piston. Replace all O-rings and the push rod guide (#21 & #22, Fig. 5). The correct installation torque for the push rod guide is 35 inch-pounds. **CAUTION:** Do not over tighten the push rod guide. Reassemble the components that were initially removed. Re-install the diaphragm (#18, Fig. 5) if it appears to be in good shape, otherwise, replace it also. **NOTE:** The diaphragm has two different surfaces. It is not bi-directional. It will fail if installed backwards! Roll the diaphragm so that the smooth surface (the pressure side) conforms to the inside of the push rod chamber cover and reassemble the six retaining screws (#26, Fig. 5) with an installation torque of 15 foot-pounds. Set up the Model DDX Deluge Valve as per the section "Resetting the Single Interlock Preaction System".

Ordering Information:

Specify:

- **Valve Model & Size** — 8" (200 mm) Model DDX Deluge Valve (P/N 6103080001)
- **Trim** — The trim set is available in individual parts, in time-saving segmentally assembled kit forms, or fully assembled to the Model DDX Deluge Valve with or without a control valve.
- **Solenoid Valve** — 175 psi (12,1 bar) or 250 psi (17,2 bar) Rated. Explosion-Proof Solenoid Valve available upon request.

(Explosion Proof Solenoid Available Upon Request)

	Trim Configurations	Trim Part Numbers
175 psi (12,1 bar) Rated Solenoid Valve	Fully Assembled to DDX Valve w/ Control Valve	6505080230
	Fully Assembled to DDX Valve w/o Control Valve	6505080231
	Segmentally Assembled (DDX Valve Sold Separately)	6503001727
	Individual Parts (DDX Valve Sold Separately)	6503001726
250 psi (17,2 bar) Rated Solenoid Valve	Fully Assembled to DDX Valve w/ Control Valve	6505080240
	Fully Assembled to DDX Valve w/o Control Valve	6505080241
	Segmentally Assembled (DDX Valve Sold Separately)	6503001729
	Individual Parts (DDX Valve Sold Separately)	6503001728

Note: For metric installations, a 2" NPT x R2. ISO 7/1 x Close Nipple (Reliable P/N 98543401) is sold separately as an adapter for the single drain outlet of the trims.

- Additional equipment (Refer to Fig. 7)

Component Part	Mfgr.	Description	Technical Bulletin
Water Supply Control Valve	Select	OS&Y, 8" (200 mm)	-
		Butterfly, 8" (200 mm)	-
Tamper Switch (Optional) for OS&Y Valve	D	Model OS&Y2	System Sensor A05-0196
Tamper Switch (Optional) for Butterfly Valve		Model P1BV2	System Sensor A05-0197
Deluge Valve	B	Model DDX 8" (200 mm)	Reliable 514/515
Single Interlock Trim Kit	B	Refer to Parts in this Bulletin	Reliable 743
Waterflow Alarm Pressure Switch	D	Model EPS10-2 (DPDT UL, FM)	System Sensor A05-0176
		Model EPSA10-2 (DPDT ULC)	
Mechanical Alarm (Optional)	A	Model C	Reliable 612/613
Releasing/Control Panel	C	Model PFC-4410-RC	Potter #5403550 Reliable 700
Batteries		12 VDC, 12 AMP Hours (90 Hours Backup) FM 12 VDC, 7 AMP Hours (60 Hours Backup)	
Optional Accessories		CA2Z (Class A Wiring Module for Initiating Circuits)	
		CAM (Class A Wiring Module for Indicating Circuits)	
		ARM-1/ARM-2 (Auxiliary Relay Module)	
	RA-4410-RC (Remote Annunciator)		
Alarm Annunciator	A	Model SSM24-8 24 VDC/Polarized Bell	Reliable 700
		Model SSM24-10 24 VDC/Polarized Bell	
		Model MA24-D 24 VDC/Polarized Sounder	
		Model MASS24LO 24 VDC/Polarized Sounder Strobe	
Trouble Annunciator	A	Model SSM24-6 24 VDC/Polarized Bell	Reliable 700
		Model MA24-D 24 VDC/Polarized Sounder	
Manual Emergency Station (Elec.)	A	Model BNG-1 (SPDT) 1 & 2 Area Detection	Reliable 700
		Model BNG-1F (DPDT) Cross Zoned Detection	
Detection	Various	Smoke, Heat Detectors, etc.	Reliable 722
Sprinklers	B	Closed Type	Reliable 110, 117, 131, 136, etc.
Supervisory Air Supply	B	Model B Air Compressor Panel	Reliable 252
		Model C Pressure Maintenance Device	

System Equipment Manufacturers

(A) Notifier

(B) The Reliable Automatic Sprinkler Co.

(C) Potter Electric Signal Company

(D) System Sensor

SINGLE INTERLOCK PREACTION SYSTEM COMPONENTS

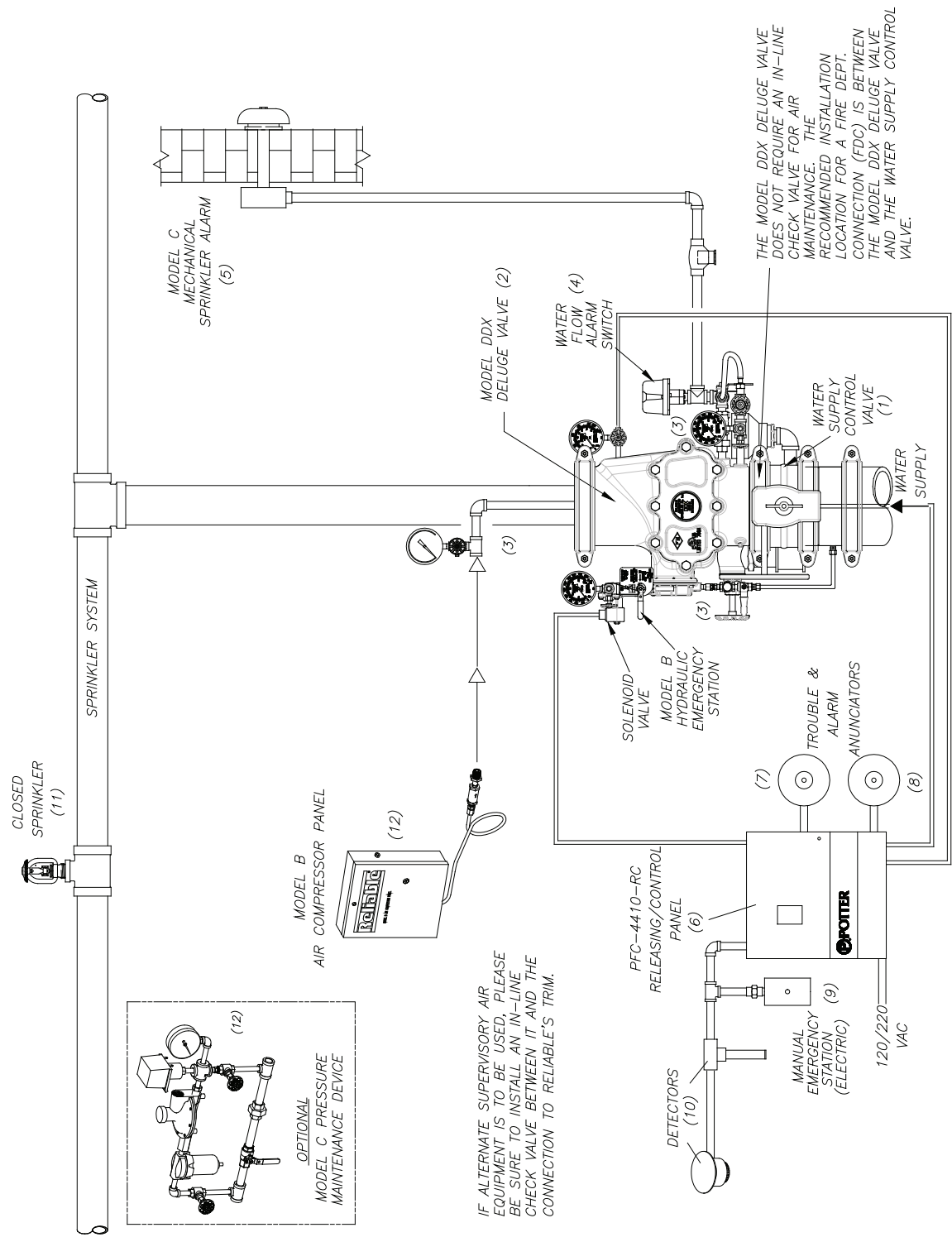

743FG07A

Fig. 7

Installation Dimensions in Inches (mm)

A	B	C	*D	E	F	G	H	J	K	L	M	N	P	Q	R
7¼ (184)	9 (229)	11¼ (285)	19¾ (492)	15½ (394)	22 (559)	9 (229)	9 (229)	5½ (140)	8½ (216)	15 (381)	2¾ (70)	4½ (114)	9 (229)	13 (330)	7¼ (184)

* Total takeout dimension for fully assembled to Model DDX Valve w/ Control Valve Configuration: 30¼ [768]

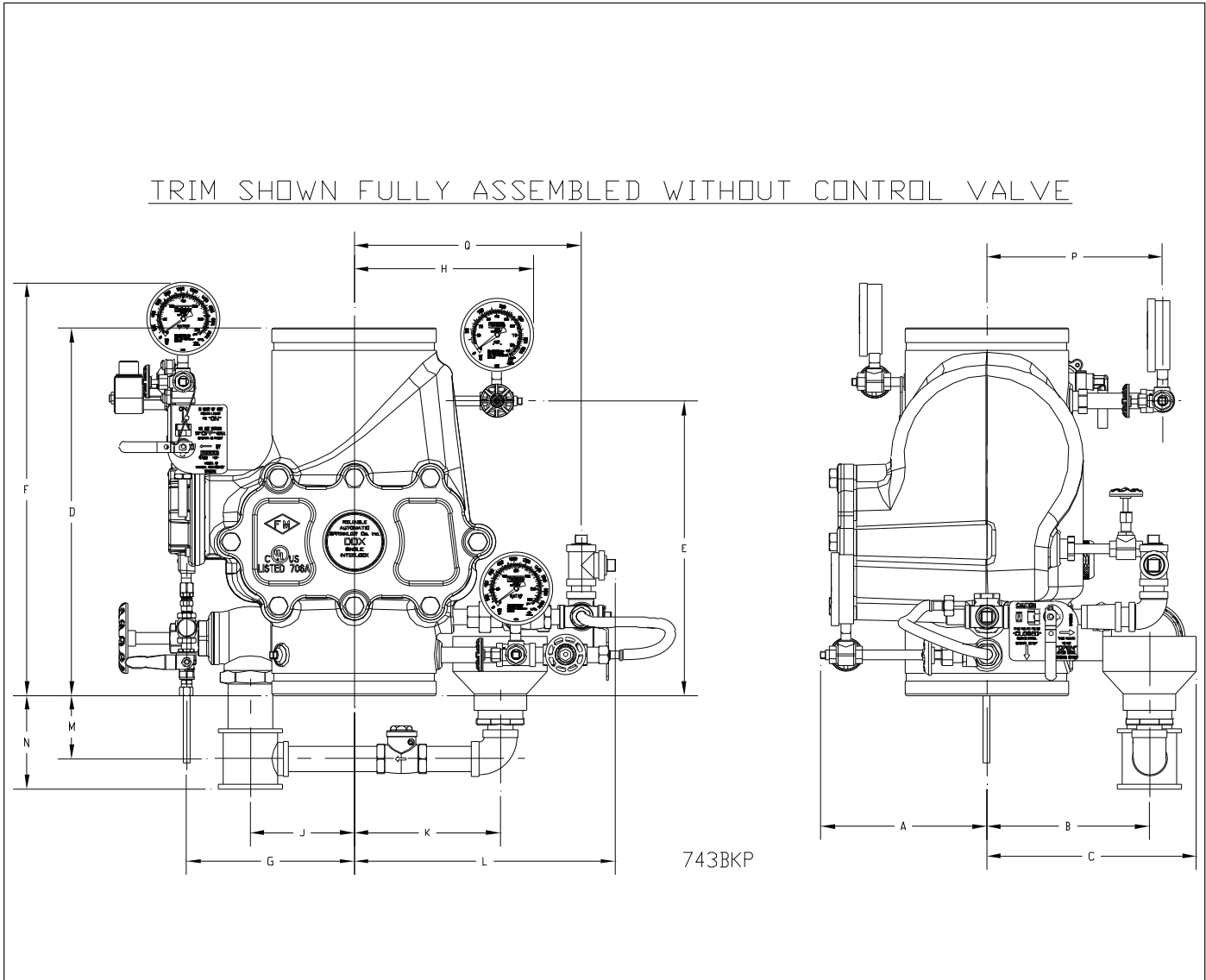

SOLENOID VALVE INSPECTIONS, TESTS AND MAINTENANCE

WARNING: THE OWNER IS RESPONSIBLE FOR MAINTAINING THE FIRE PROTECTION SYSTEM IN PROPER OPERATING CONDITION. ANY SYSTEM MAINTENANCE OR TESTING THAT INVOLVES PLACING A CONTROL VALVE OR DETECTION SYSTEM OUT OF SERVICE MAY ELIMINATE THE FIRE PROTECTION OF THAT SYSTEM. PRIOR TO PROCEEDING, NOTIFY ALL AUTHORITIES HAVING JURISDICTION. CONSIDERATION SHOULD BE GIVEN TO EMPLOYMENT OF A FIRE PATROL IN THE AFFECTED AREA.

WARNING: PRIOR TO OPERATING THE SOLENOID VALVE, BE SURE TO CLOSE THE SYSTEM CONTROL VALVE TO AVOID UNINTENTIONAL OPERATION OF THE DELUGE VALVE

1. Inspections: It is imperative that the system be inspected and tested in accordance with NFPA 25 on a regular basis. The frequency of the inspections may vary due to contaminated water supplies, corrosive water supplies, or corrosive atmospheres. In addition, the alarm devices, detection systems, or other connected trim may require a more frequent schedule. Refer to the system description and applicable codes for minimum requirements.
2. The valve must be inspected at least monthly for cracks, corrosion, leakage, etc., and cleaned, repaired, or replaced as necessary.
3. If leakage is suspected through the solenoid valve, the valve diaphragms and seats should be inspected and if necessary, repaired or replaced.

WARNING: CLOSE SYSTEM CONTROL VALVE, TURN OFF POWER SUPPLY, AND DEPRESSURIZE VALVE BEFORE DISASSEMBLING VALVE. IT IS NOT NECESSARY TO REMOVE THE VALVE FROM THE PIPE LINE TO MAKE INSPECTIONS.

4. When lubricating valve components, use high grade silicone grease (Dow Corning® 111 Compound Lubricant or equal).
5. When reassembling, tighten parts to torque values indicated in the manufacturer's maintenance instructions (packed with valve).
6. After maintenance is completed, operate the valve a few times to be sure of proper operation. A metallic "click" signifies the solenoid is operating.
7. All service must be performed by qualified personnel. Upon completion of inspections or replacement of the valve, the entire system must be checked for proper operation. See appropriate system description and testing instructions for additional information.

Reliable...For Complete Protection

Reliable offers a wide selection of sprinkler components. Following are some of the many precision-made Reliable products that guard life and property from fire around the clock.

- Automatic sprinklers
- Flush automatic sprinklers
- Recessed automatic sprinklers
- Concealed automatic sprinklers
- Adjustable automatic sprinklers
- Dry automatic sprinklers
- Intermediate level sprinklers
- Open sprinklers
- Spray nozzles
- Alarm valves
- Retarding chambers
- Dry pipe valves
- Accelerators for dry pipe valves
- Mechanical sprinkler alarms
- Electrical sprinkler alarm switches
- Water flow detectors
- Deluge valves
- Detector check valves
- Check valves
- Electrical system
- Sprinkler emergency cabinets
- Sprinkler wrenches
- Sprinkler escutcheons and guards
- Inspectors test connections
- Sight drains
- Ball drips and drum drips
- Control valve seals
- Air maintenance devices
- Air compressors
- Pressure gauges/identification signs
- Fire department connection

The equipment presented in this bulletin is to be installed in accordance with the latest published Standards of the National Fire Protection Association, Factory Mutual Research Corporation, or other similar organizations and also with the provisions of governmental codes or ordinances whenever applicable. Products manufactured and distributed by Reliable have been protecting life and property for over 90 years, and are installed and serviced by the most highly qualified and reputable sprinkler contractors located throughout the United States, Canada and foreign countries.

Manufactured by

Reliable[®]

The Reliable Automatic Sprinkler Co., Inc.
(800) 431-1588 Sales Offices
(800) 848-6051 Sales Fax
(914) 829-2042 Corporate Offices
www.reliablesprinkler.com Internet Address



Revision lines indicate updated or new data.

EG. Printed in U.S.A 01/11 P/N 999970355