



**Model DDX PrePaK, Type D  
Preaction System  
4"(100mm) & 6"(150mm)**

# Instructions for Installation, Operation, Care and Maintenance

**Single Interlock  
Double Interlock**

**10 PSI (0,7 bar) Pneumatic Supervising Pressure**

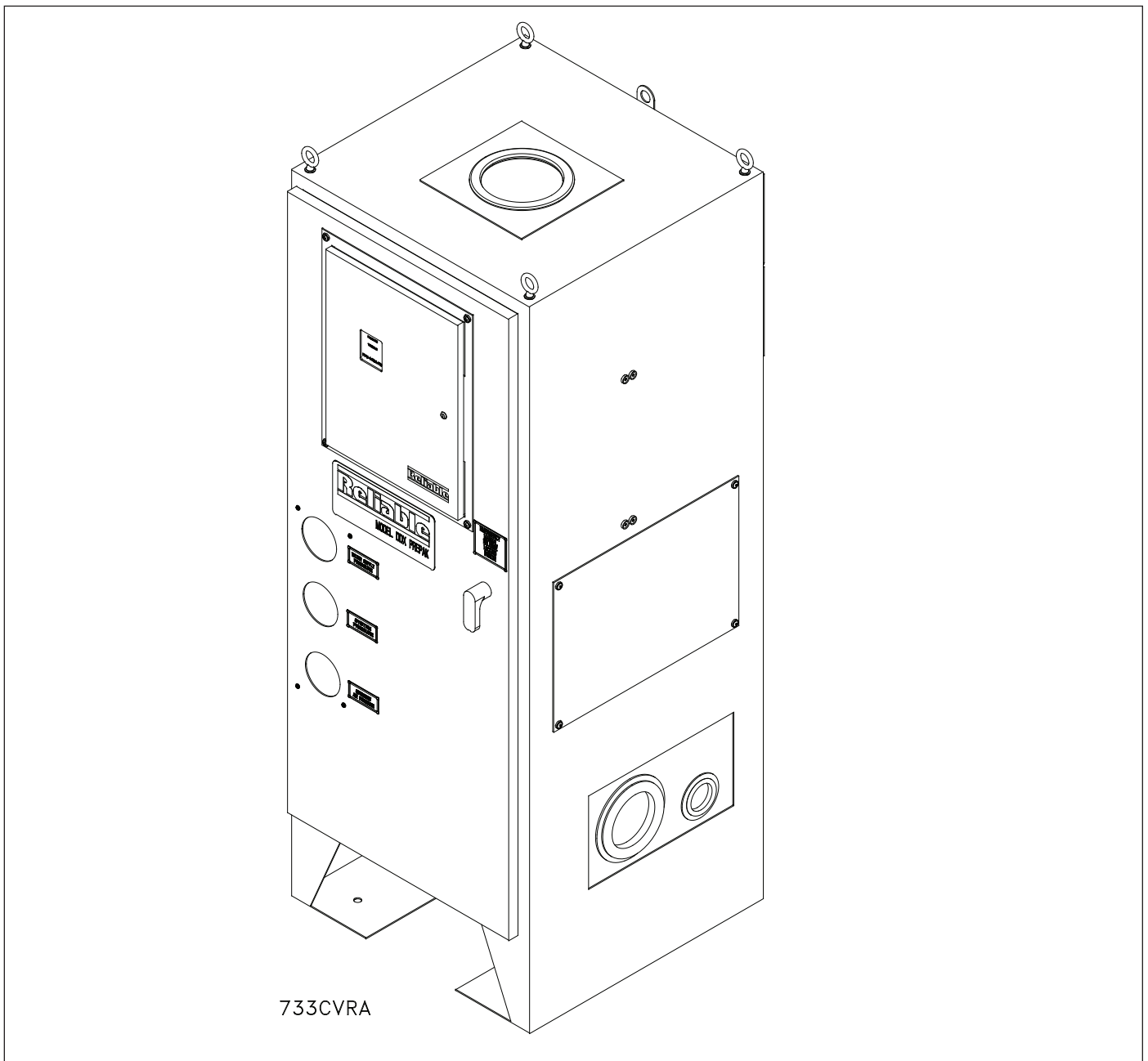

733CVRA

## General Description

The Reliable Model DDX 4" (100 mm) and 6" (150 mm) PrePaKs are completely self-contained, supervised preaction systems that can be readily installed within a floor space of 4.7 ft<sup>2</sup> (0.44 m<sup>2</sup>) (not including door swing). Installation of the PrePaK (not including exterior devices, i.e., detectors and alarm bells), requires just three piping connections: a 4" (100 mm) or 6" (150 mm) supply line, a 4" (100 mm) or 6" (150 mm) system line, and a 2" (50 mm) drain line. Reference locations of these piping connections are shown in Fig.1. Also, two 120 / 220 VAC electrical supply connections are required. **Note:** The Model DDX PrePaK is available with its air compressor and Potter Model PFC-4410-RC Releasing/Control Panel wired for a 120 VAC / 60Hz or for a 220 VAC / 50 Hz power supply.

The Reliable Model DDX PrePaK contains the following components within its 25.7" (0.65 m) W x 28.9" (0.73 m) D x 68" (1.73 m) H 12-gauge steel enclosure:

- One Reliable Model DDX 4" (100 mm) or 6" (150 mm) Deluge Valve with Type D Double Interlock Preaction Trim set (See Reliable Bulletin 728).
- One Gast Model 5HCD-108-M550NGX ¾ Hp Air Compressor (a 1½ Hp Model 7HDD-16-M750X, Air Compressor is optional in the 6" (150 mm) PrePaK only).
- One 8 gallon (30.3 liter) air tank.
- One Potter Model PFC-4410-RC Releasing/Control Panel (See Potter Manual #5403550).
- One Pressure Maintenance Device for system air supervision (contains regulator, check valve, strainer, and rapid-fill option).
- All required fittings, gauges, electrical connectors, and electrical devices to utilize the system in single interlock, single interlock cross-zoned, double interlock, and double interlock cross-zoned applications.

The Reliable Model DDX PrePaK utilizes the Potter Model PFC-4410-RC Releasing Control Panel. This fully programmable, microprocessor-based releasing panel is Underwriters Laboratories, Inc. Listed and is in compliance with NFPA 13 and NFPA 72. Because the PFC-4410-RC is totally zone and output programmable, the Reliable Model DDX PrePaK can be utilized in many different preaction applications without having to rewire any of the factory installed devices. Once the previously described connections are completed, the 24 VDC detectors, output devices, and relay contacts may be connected to achieve the desired system implementation.

The Model DDX PrePaK can be used in both single and double interlock applications. Reliable Single and Double Interlock Preaction Systems are designed for water sensitive areas that require protection from inadvertent water flow into the sprinkler system piping.

The major benefits of a single/double interlock preaction System, when compared with a wet pipe system, are as follows:

- A. A fire alarm sounds prior to the flow of water from a sprinkler, which may enable extinguishing the fire by handheld means before the operation of any sprinkler head occurs.
- B. An annunciator signals whenever the integrity of piping or sprinklers is accidentally or intentionally disturbed; however, no water flow or water damage will result at that time.
- C. Speedy detection and an early fire alarm are provided by fire detectors, without the delay associated with water delivery time in the event of a fire. Note that with a wet pipe

system, the fire alarm is delayed until after water has begun flowing from and operated sprinkler head.

In single interlock applications, one electrical detector senses the presence of fire, thereby causing the electrical releasing control panel to activate fire alarm devices and energize the solenoid releasing valve in the open position. Note that arranging detectors in a cross-zoned pattern will require operation of two detectors before the solenoid valve can open (**Note:** Cross-zoned detection systems are not permitted in New York City and are not Factory Mutual Approved). The solenoid valve, when closed, is preserving supply water pressure in the deluge valve's push-rod chamber. Actuating the solenoid valve releases that water pressure which allows the valve to open.

To fully operate a single interlock system with cross-zoned detection, two separate electrical detection systems must activate and a sprinkler must open. During the early stages of a fire, smoke or heat activates the first detector, which causes the control panel to produce a local alarm and an alarm at the main fire alarm panel. Electrical relays inside the releasing control panel can be used to shut down air moving equipment or activate security doors and other electrical devices when the panel goes into this first condition. Subsequent activation of a second, nearby or adjacent detector, on a separate detection system, will cause the panel to energize the solenoid valve open and release water into the sprinkler piping. Water flowing into the sprinkler piping will simultaneously produce water pressure that causes the transfer of contacts in the alarm pressure switch mounted in the riser assembly, thereby activating a water flow alarm device. The flow of water into the sprinkler piping effectively converts the dry system into a wet pipe system. In the event the fire subsequently produces sufficient heat to operate a sprinkler head, water will flow from that sprinkler, controlling the fire.

To flow water into a double interlock preaction system, two events must take place. A fire detection device must operate, and a pressure switch must be operated by the loss of system pressure (sprinkler operation). These two signals, both an electric signal and a pneumatic signal, must coexist at the releasing control panel, which only then will energize the solenoid releasing valve, causing water flow into the sprinkler system and out of the open sprinkler(s).

In the event that the system piping is ruptured or a sprinkler head is accidentally opened, the system pressure switch will operate and an alarm will sound. The riser assembly, however, will not release water since the solenoid valve remains closed due to only one input into the releasing control panel.

When using the Reliable Model DDX PrePaK, in either single or double interlock applications, the sprinkler system is pressurized (supervised) with air provided by the air compressor and is monitored by a system pressure switch.

A Model B Hydraulic Manual Emergency Releasing station is standard equipment in the Model DDX PrePaK. It consists of an aluminum nameplate mechanically attached to a ball valve. The valve handle in its OFF position is guarded against accidental turning to the ON position (and system discharge) by a nylon cable tie provided with the PrePaK assembly. The cable tie is designed to allow, in case of an emergency, forceful turning of the valve handle to the ON position.

# MODEL DDX PREPAK ASSEMBLY DIMENSIONS

ASSEMBLY	A	B	C	D	E	F	G	H	J	K	L	M
4" (100MM) DDX	25.7 [65.3]	28.9 [73.36]	68.0 [172.7]	50.5 [128.3]	13.5 [34.3]	13.8 [35.1]	13.8 [35.1]	6.3 [16.0]	12.6 [32.0]	13.6 [34.5]	1.9 [4.8]	11.9 [30.2]
6" (150MM) DDX	25.7 [65.3]	28.9 [73.36]	68.0 [172.7]	50.5 [128.3]	13.5 [34.3]	13.8 [35.1]	13.8 [35.1]	5.8 [14.7]	12.6 [32.0]	14.7 [37.3]	1.9 [4.8]	10.4 [26.4]

SOME COMPONENTS  
OMITTED FOR CLARITY

DIMENSIONS: INCHES  
[CM]

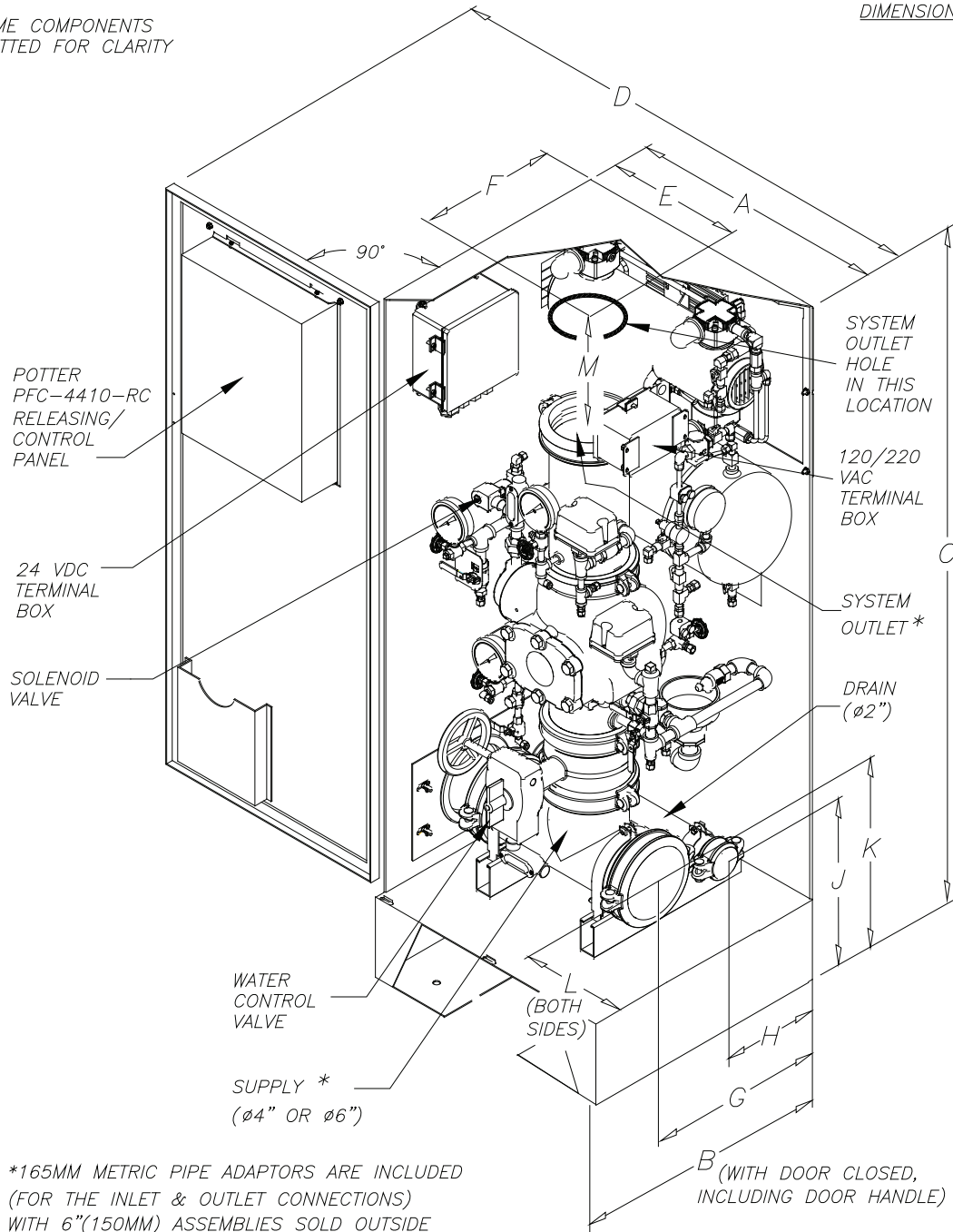

733FG01A

Fig. 1

## Approvals

- Underwriters Laboratories, Inc. Listed and Certified for Canada\* (cULus) as an assembled unit in the "Special System Water Control Valves Assembled Units" category, (VKYL).
- Factory Mutual (FM) Approved, as PrePak Single Interlock and Double Interlock Preaction Systems.
  - \* Electrical devices and control panel must be specified to meet Canadian requirements. This option is available.
- NYC MEA 258-93-E

**Note:** Although PrePak units are UL Listed, custom built units are sometimes supplied upon request. The components within these special units maintain their individual Listings/Approvals, whereas the assembled units do not.

PrePak units are also available without their door-mounted Potter PFC-4410-RC Releasing/ Control Panel and Air Compressor. These units will still retain their Listings/Approvals, however the installing contractor should make sure that any remote controlled Releasing/Control Panels used with these units are Listed/Approved and programmed to handle the required sequence of operation necessary to operate the automatic sprinkler system. Any unauthorized modification or addition made on-site to a factory-built Listed/Approved unit will void the Listing/Approval. Such modifications or additions may void the unit's warranty as well. Consult Reliable's Technical Services Department before proceeding with any such modifications or additions.

## Technical Data

- The Reliable Model DDX 4" (100 mm) and 6" (150 mm) PrePaks are rated for a minimum supply pressure of 20 psi (1,4 bar) and a maximum supply pressure of 250 psi (17,2 bar). Note: 1 bar = 100 kPa.
- Friction loss, expressed in equivalent length of Schedule 40 pipe and based on Hazen-Williams Formula with C=120 and a flowing velocity of 15 ft/s (4.6 m/s), is:
  - 4" (100 mm) - 58 ft. (17.7 m)
  - 6" (150 mm) - 71.4 ft. (21.8 m)

These values account for the Model DDX Deluge Valve, supply manifold tee, butterfly control valve, and small pipe/manifold located directly above Model DDX Deluge Valve.
- Shipping Weight:
  - 4" (100 mm) - 680 lbs (308 kg)
  - 6" (150 mm) - 770 lbs (349 kg)

Dimensions: 25.7" W x 28.9" D x 68" H  
(0.65 m W x 0.73 m D x 1.73 m H)

(Refer to Fig. 1 for additional dimensions)
- Grooved end connections:

Groove Dimensions (Supply Manifold)				
Pipe Size	Outlet Diameter	Groove Diameter	Groove Width	Outlet Face to Groove
4" (100mm)	4.500" (114mm)	4.334" (110mm)	3/8" (10mm)	5/8" (16mm)
6" (150mm)	6.625" (168mm)	6.455" (164mm)		
Groove Dimensions (Drain Manifold)				
Pipe Size	Outlet Diameter	Groove Diameter	Groove Width	Outlet Face to Groove
2" (50mm)	2.375" (60mm)	2.250" (57mm)	5/16" (8mm)	5/8" (16mm)

The following is a list of Technical Data Bulletins which describe the valves and devices which are used in the system:

Deluge Valve	510/511
Type D Double Interlock Preaction Trim	728
Low Air Pressure Switch	System Sensor A05-0176
Hydraulic Emergency Station (Model A) 506 Mechanical Sprinkler Alarm	612/613
Solenoid Valve	718
Alarm Pressure switch	System Sensor A05-0176
Control Panel	Potter Manual #5403550
Detectors	722
Fire Alarm Devices	700

The following table provides a quick reference to various programs (found in this bulletin and the Potter Manual #5403550) that may be utilized with a Model DDX PrePak:

Desired Applications <sup>(1)</sup>	Description	Program No.
Single Interlock	Single Hazard, 2 Alarm Zones with 1 Waterflow Zone and 2 Supervisory Zones	Potter Program #6
		Custom Program #1 (NYC)
Single Interlock, Cross-Zoned	Single Hazard, Cross-Zoned, 2 Alarm Zones with 1 waterflow Zone and 2 Supervisory Zones	Potter Program #7 <sup>(2)</sup>

<sup>(1)</sup> Refer to Potter Manual # 5403550 included with the PrePak, for other programming options available.

<sup>(2)</sup> Factory Program setting.

## System Design Considerations

The automatic sprinklers, releasing devices, fire detection devices, manual pull stations, and signaling devices which are utilized with the Reliable Model DDX 4" (100 mm) and 6" (150 mm) PrePaks must be UL and/or ULC Listed or FM Approved, as applicable.

The steel enclosure and all the interconnecting piping must be located indoors in a readily visible and accessible location and in an area that can be maintained at a minimum temperature of 40°F (4°C). **Note:** Heat tracing is not permitted. The solenoid valve is operated and supervised by the Potter Model PFC-4410-RC Releasing Control Panel. Details on the electrical connections of this system to the Potter Panel can be found in the Potter Manual #5403550, Installation, Operation and Instruction of PFC-4410-RC Releasing Control Panel (this manual is included with other pertinent manuals and shipped inside the enclosure). This panel is fully zone and output programmable and may be adapted to several applications.

## System Supervising Pressure Requirements

In accordance with NFPA 13, when using the Reliable Model DDX 4" (100 mm) or 6" (150 mm) PrePaK in double interlock applications, a minimum of 7 psi (0,5 bar) pneumatic pressure is required to supervise the sprinkler system. When initially filling the system with air, the enclosure's door should remain open in order to provide maximum intake air flow to the air compressor. The air compressor is connected to an 8 gallon (30,3 liter) ASME rated storage tank. This tank functions as a reservoir, providing make-up air to compensate for small, intermittent leaks in the sprinkler system. It should be noted that significant leaks may overburden this storage tank, thereby causing the air compressor to continuously cycle on and off.

The Pressure Maintenance Device supplied with the system (refer to Fig. 8), is factory set to maintain system pneumatic pressure at approximately 10 psi (0,7 bar). Readjusting system pressure to approximately 10 psi (0,7 bar), if necessary, is accomplished by first loosening the locknut on the air pressure regulator and turning the adjustment screw (refer to Fig. 8). The system air pressure gauge that is attached to the vertical pipe/manifold (mounted directly above the Model DDX Deluge Valve) may be used to verify the correct level of pneumatic pressure.

The system air pressure switch (refer to Fig. 8) is factory set to operate between 8 psi and 4 psi (0,6 bar and 0,3 bar) with decreasing pressure. Adjustment, if required, should be made according to System Sensor Bulletin A05-0176 included with the switch.

## System Electrical Requirements

All releasing, alarm, and detection devices in the Reliable Model DDX 4" (100 mm) and 6" (150 mm) PrePaKs are supervised by a Potter Model PFC-4410-RC Releasing Control Panel. To utilize one of the doors of the steel enclosure as a mount for the releasing control panel, all of the terminals are translated to two, water-tight terminal boxes mounted on the interior of the enclosure. **Note:** the EOL (End of Line) resistors have also been relocated. It is from these terminal boxes that all field wiring is connected. There is one terminal box that contains the 24 VDC connections and one that contains the 120 / 220 VAC connections. The Reliable Model DDX PrePaK is delivered with five factory-installed electrical devices. They consist of the following:

1. A system air pressure switch, which is used to monitor sprinkler piping.
2. An alarm pressure switch, which indicates an actuation of the deluge valve.
3. A normally-closed, releasing solenoid valve, which is used to actuate the deluge valve.
4. A ¾ HP tank-mounted air compressor with 8 gallon (30,3 liter) tank (1½ HP compressor is optional with 6" (150 mm) system only).
5. A supervised butterfly water control valve.

The factory electrical connections of these devices are illustrated in Fig. 4. For information on how to install fire detection devices to initiating Zones 1 and 2 of the Potter Model PFC-4410-RC Releasing Control Panel, refer to Fig. 5 or Fig. 6. For information on how to install output devices, i.e., alarm bells or trouble annunciators, to the Potter Model PFC-4410-RC Releasing Control Panel, refer to Fig. 7. The power supply, standby emergency power supply, battery charger and rectifier circuitry are all contained within the PFC-4410-RC panel. Batteries that provide 90 hours of standby power are provided with the panel. For additional information and detailed wiring diagrams, refer to Potter Manual #5403550, Installation, Operation and Instruction of PFC-4410-RC Releasing Control Panel.

**Caution:** Repairs or disassembly of the solenoid valve should only be done by a trained technician. An improperly repaired or partially assembled solenoid valve could result in failure of the valve to operate.

## System Operation (Single Interlock)

To fully activate (water flow) the Reliable Model DDX 4" (100 mm) or 6" (150 mm) PrePaK in a single interlock application, a fire detection device (smoke, heat, etc.) (two detectors with cross-zoned detection) must activate. Subsequently, a sprinkler head must open to discharge water on the fire.

When the single interlock preaction system is set for service, the supply pressure acts both on the underside of the deluge valve's clapper and on the valve's push rod by means of the pressurized push rod chamber. The pressure force acting on the push rod, when utilized with the mechanical advantage of the deluge valve's lever, is more than sufficient to hold the clapper in the closed position against the water supply pressure.

Energizing the releasing solenoid valve allows the deluge valve's push-rod chamber to be vented to drain through its outlet. Since the pressure cannot be replenished through the inlet restriction as rapidly as it is vented through the outlet, the push-rod chamber pressure falls rapidly. When the push-rod chamber pressure drops below one-third of the supply pressure, the opening force acting beneath the clapper becomes greater than the push-rod force acting on the lever. This causes the clapper to open. Refer to Reliable Bulletins 510 and 511 for further details.

Once the clapper has opened, the lever acts as a latch, preventing the clapper from returning to the closed position. Water from the supply flows through the deluge valve into the system piping. Water also flows through the deluge valve alarm outlet to activate any water flow alarm devices. Note that the solenoid valve will be maintained open by the Potter Model PFC-4410-RC Releasing Control Panel's latching feature until it is reset for operation.

After system shutdown and draining, the Model DDX Deluge Valve is easily reset without special tools (see Fig.8). Restore detection devices by resetting or replacing any operated device. Once detection devices are restored, (the Potter Model PFC-4410-RC Releasing Control Panel reset), and supply pressure is re-supplied to the push-rod chamber, the deluge valve is reset.

## System Operation (Double Interlock)

To fully activate (water flow) the Reliable Model DDX 4" (100 mm) or 6" (150 mm) PrePaK in a double interlock application, two independent events must coexist. An electrical fire detection device (smoke, heat, etc.) and the system air pressure switch must be activated. This pressure switch is activated by a reduction of the system's pneumatic pressure (as a result of sprinkler operation). Both of these events will cause the control panel to energize the solenoid valve, thereby releasing water through the deluge valve and into the sprinkler system. The initiation of either one of these events will only cause an alarm to announce, and will not fill the sprinkler system.

When the double interlock preaction system is set for service, the supply pressure acts both on the underside of the deluge valve's clapper and on the valve's push rod by means of the pressurized push rod chamber. The pressure force acting on the push rod, when utilized with the mechanical advantage of the deluge valve's lever, is more than sufficient to hold the clapper in the closed position against the water supply pressure.

Energizing the releasing solenoid valve allows the deluge valve's push-rod chamber to be vented to drain through its outlet. Since the pressure cannot be replenished through the inlet restriction as rapidly as it is vented through the outlet, the push-rod chamber pressure falls rapidly. When the push-rod chamber pressure drops below one-third of the supply pressure, the opening force acting beneath the clapper becomes greater than the push-rod force acting on the lever. This causes the clapper to open. Refer to Reliable Bulletins 510 and 511 for further details.

Once the clapper has opened, the lever acts as a latch, preventing the clapper from returning to the closed position. Water from the supply flows through the deluge valve into the system piping. Water also flows through the deluge valve alarm outlet to activate any water flow alarm devices. Note that the solenoid valve will be maintained open by the Potter Model PFC-4410-RC Releasing Control Panel's latching feature until it is reset for operation.

After system shutdown and draining, the Model DDX Deluge Valve is easily reset without special tools (see Fig.8). Restore detection devices by resetting or replacing any operated device. Once detection devices are restored, (the Potter Model PFC-4410-RC Releasing Control Panel reset), and supply pressure is re-supplied to the push-rod chamber, the deluge valve is reset.

## Maintenance

The Reliable Model DDX PrePaK and associated equipment shall periodically be given a thorough inspection and test. NFPA 25, Inspection, Testing and Maintenance of water Based Fire Protection Systems, provides minimum maintenance requirements. Systems should be tested, operated, cleaned and inspected at least annually, and parts replaced as required. Periodically open the air/condensate drain valve (refer to Fig. 8) beneath the air tank to drain any condensate accumulation. Bulletin 510 provides information for maintaining the Model DDX Deluge Valve. Potter Manual #5403550 provides information for maintaining the PFC-4410-RC Releasing Control Panel.

## Resetting Single And Double Interlock Systems

Refer to Fig. 8.

1. Close the main valve controlling water supply to the deluge valve and close the 1/4" air shutoff valve, valve J.
2. Close the pushrod chamber supply valve, valve A.
3. Open the main drain valve, valve B, and drain system.
4. Open all drain valves and vents at low points throughout the system, closing them when flow of water has stopped. Open valve D. **Note:** The above steps accomplish the relieving of pressure in the pushrod chamber of the deluge valve.
5. Push in the plunger of ball drip valve, valve F, to force the ball from its seat, and drain any water in the alarm line.
6. With the Model B Manual Emergency Station, valve D, open, push in and rotate the deluge valve's external reset knob clockwise until you hear a distinct clicking noise, indicating that the clapper has closed. **Note:** The reset knob can be rotated only after pressure in the pushrod chamber is reduced to atmospheric conditions (0 psig).
7. Inspect and replace any portion of the sprinkler system subjected to fire conditions.
8. Verify that the following valves are in their respective positions:  
valve C – open, valve E – closed, valve H – closed,  
valve K – open, valve M – closed.
9. Open valve A and allow water to fill the deluge valve's push-rod chamber. Close valve D.
10. Bleed any air from the actuation piping by energizing the solenoid valve. This is done by operating a detector or an electric manual emergency station. While water is flowing through the solenoid valve, cause it to close by pressing the system reset button on the Potter PFC-4410-RC Releasing Control Panel. **Note:** All detection devices must be reset before the releasing/control panel can be reset.
11. Open the 1/4" air shutoff valve, valve J, to restore air pressure in the sprinkler system. The rapid air-fill shutoff valve, valve M, may be opened here to expedite the filling of the sprinkler system.
12. Open slightly the main valve controlling water supply to the Model DDX Deluge Valve, closing drain valve B when water flows. Observe if water leaks through the ball drip valve, valve F, into the drip cup, G. If no leak occurs, the deluge valve's clapper is sealed. Open slowly, and verify that the main valve controlling water supply is fully opened and properly monitored.
13. Verify that valve A is open.
14. Secure the handle of the Model B Manual Emergency Station, valve D, in the OFF position with a nylon tie (supplied with the assembly).
15. Press the system reset button on the Potter PFC-4410-RC Panel to place the system in the ready condition. **Note:** All detection devices must be reset before the panel can be reset.

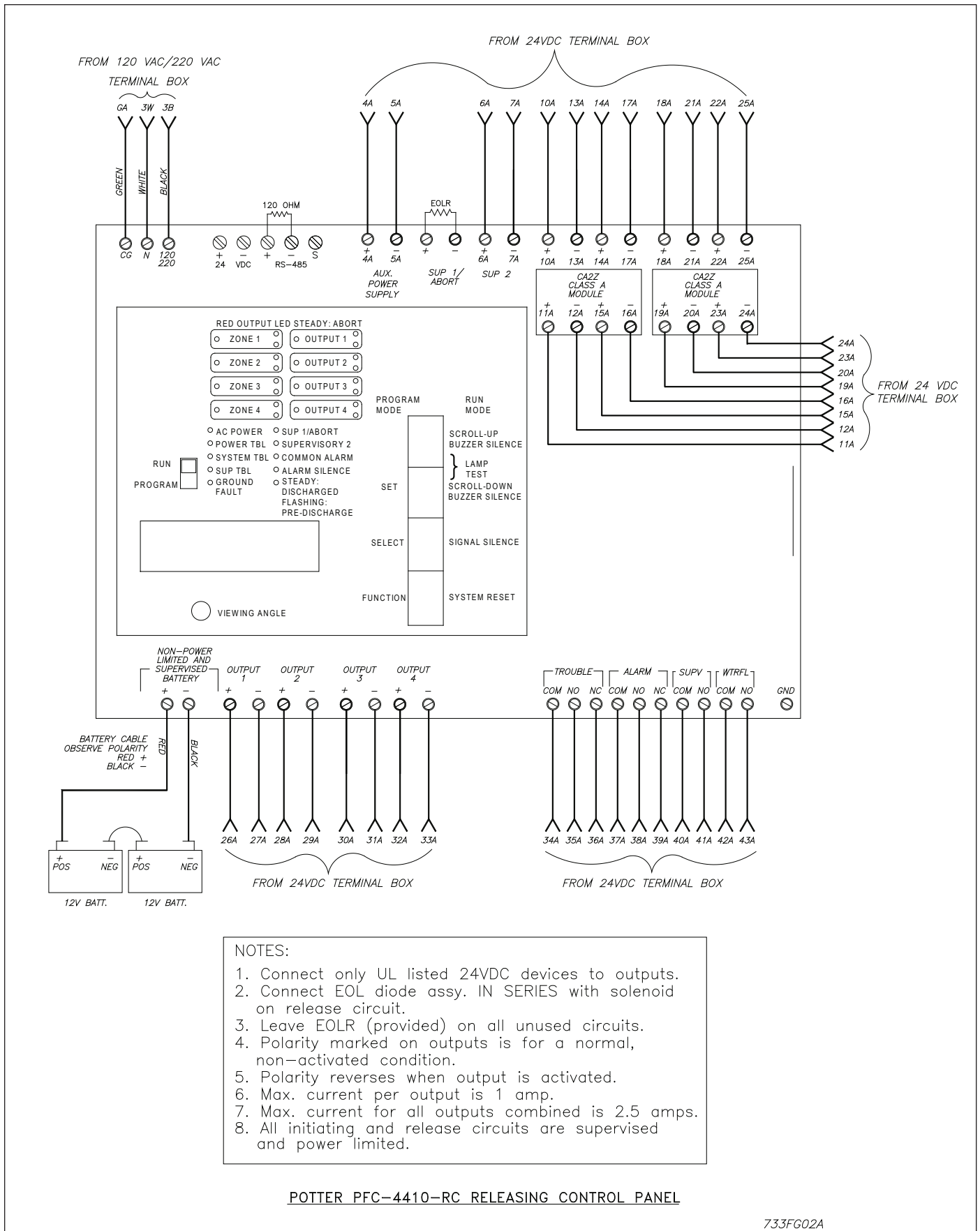
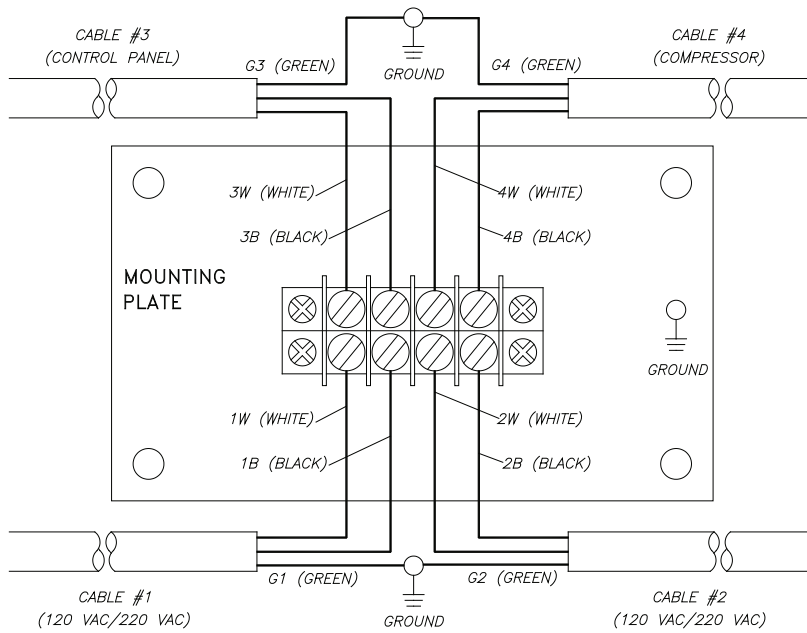
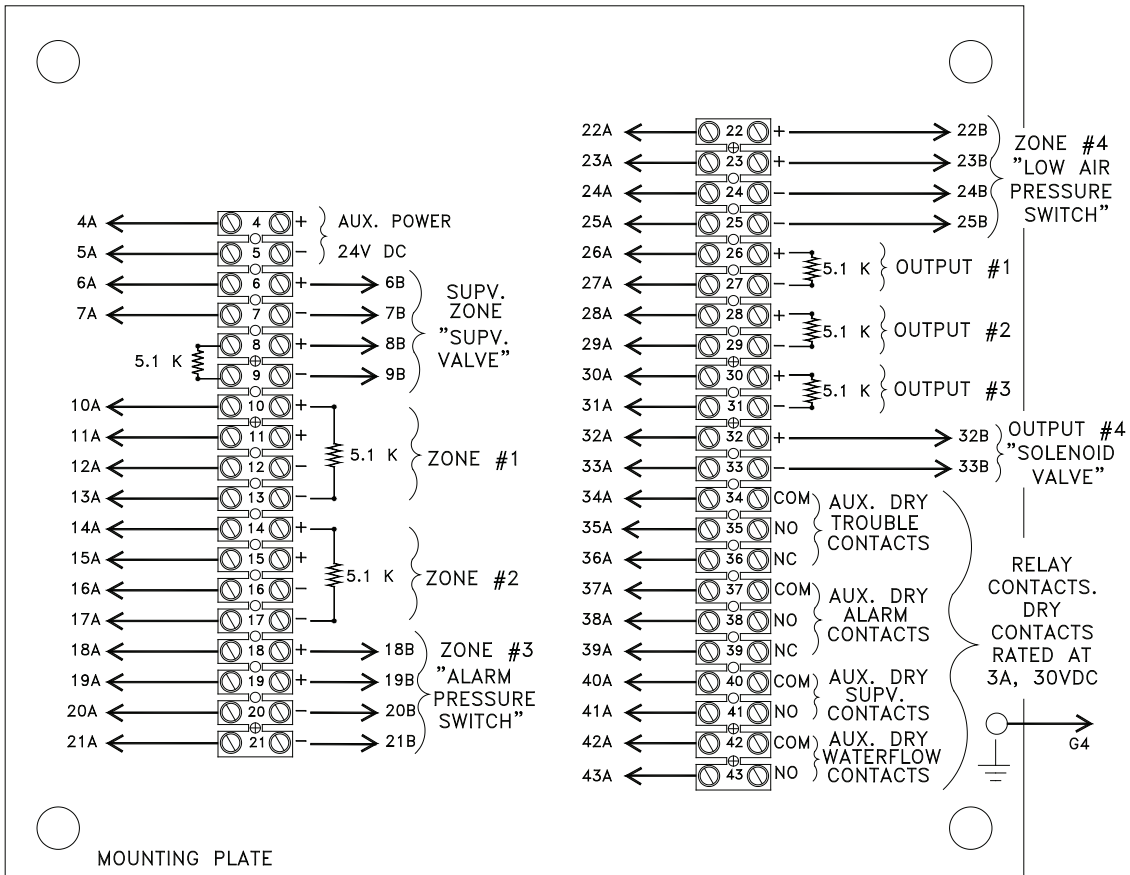

Fig. 2



120 VAC/220 VAC TERMINAL BOX (FACTORY CONNECTIONS)



733FG03A

24 VDC TERMINAL BOX (FACTORY CONNECTIONS)

Fig. 3

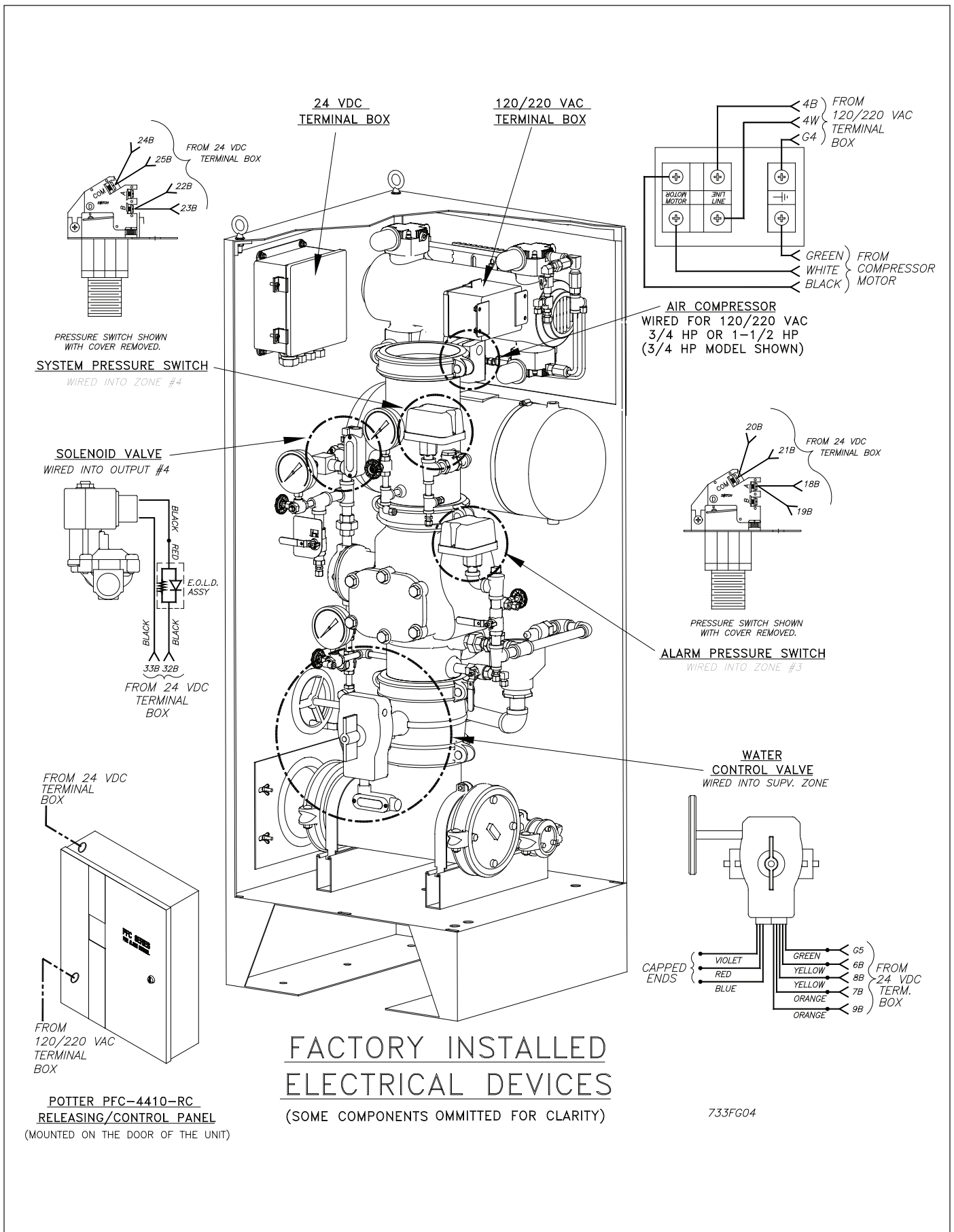
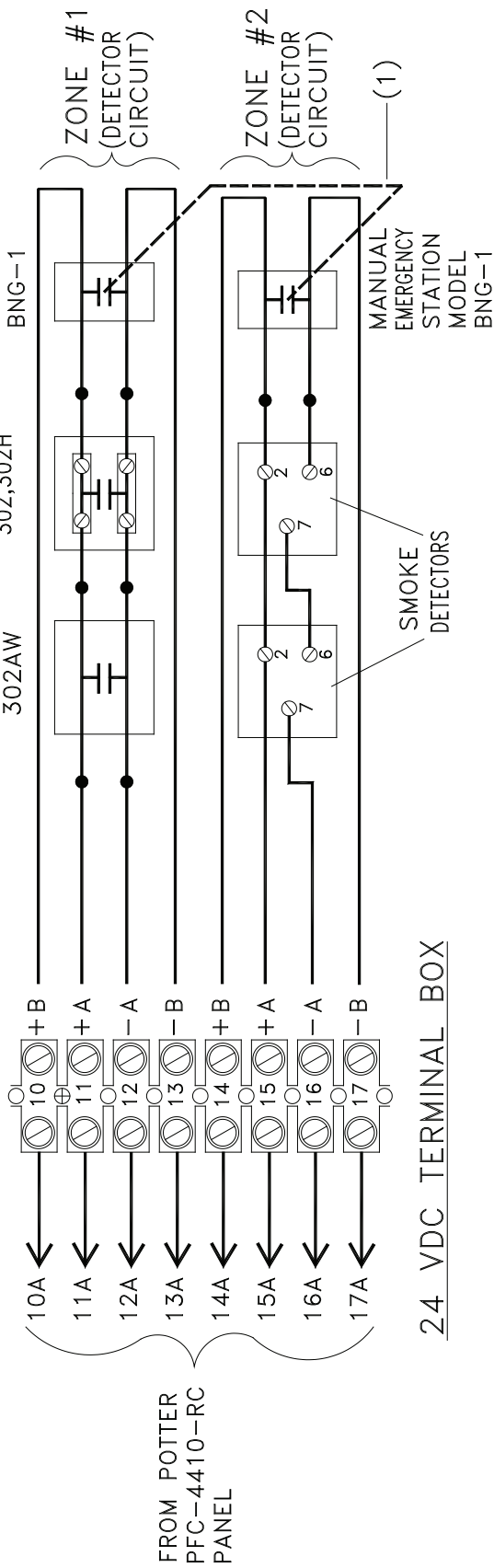

Fig. 4

SMOKE DETECTOR:  
 PHOTOELECTRIC, MODEL PSD 7125, BASE MODEL 70-201000-001  
 IONIZATION, MODEL CPD 7021, BASE MODEL 70-201000-001  
 U.L. LISTED

THERMAL DETECTOR:  
 INTERIOR, MODELS 302 AND 302H  
 WEATHER PROOF, MODEL 302AW  
 U.L. LISTED, F.M. APPROVED



CLASS 'A' DETECTOR CIRCUIT WIRING

- (1) USE MANUAL EMERGENCY STATION MODEL BNG-1F WHEN USING EITHER CROSS-ZONED DETECTION\* OR THE DOUBLE INTERLOCK PREACTION SYSTEM OPTION. THIS STATION ACTIVATES BOTH DETECTION CIRCUITS SIMULTANEOUSLY.

\*NOT PERMITTED IN NEW YORK CITY.  
 \*NOT FM APPROVED.

733FG05

Fig. 5

SMOKE DETECTOR:  
 PHOTOELECTRIC, MODEL PSD 7125, BASE MODEL 70-201000-001  
 IONIZATION, MODEL CPD 7021, BASE MODEL 70-201000-001  
 U.L. LISTED

THERMAL DETECTOR:  
 INTERIOR, MODELS 302 AND 302H  
 WEATHER PROOF, MODEL 302AW  
 U.L. LISTED, F.M. APPROVED

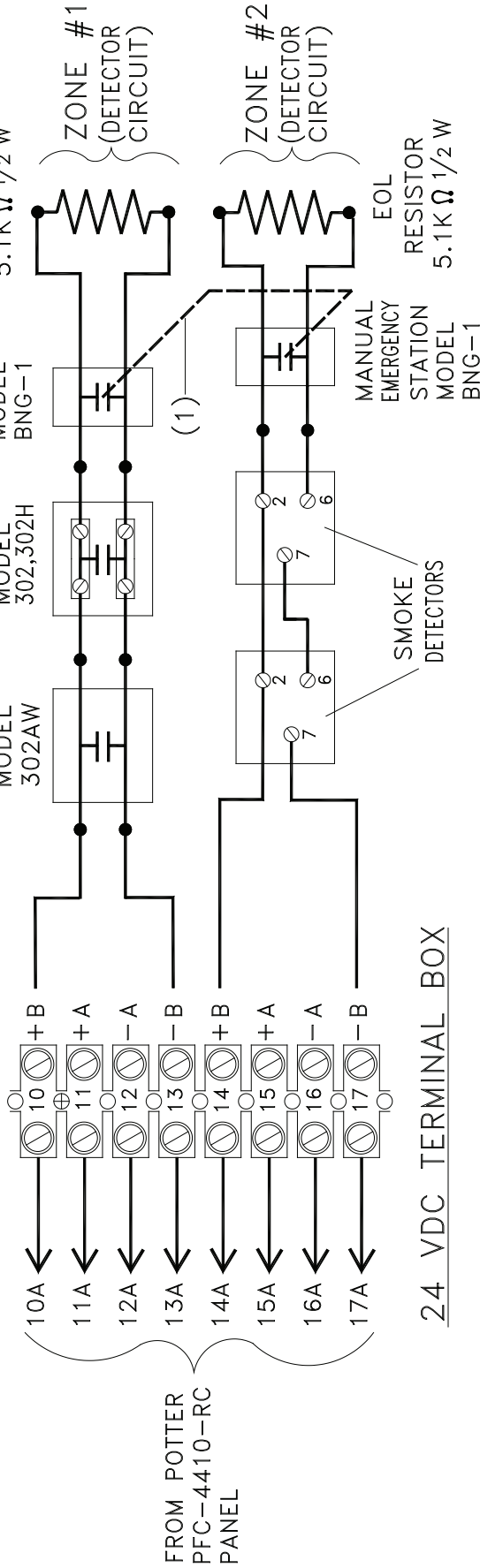

CLASS 'B' DETECTOR CIRCUIT WIRING

- (1) USE MANUAL EMERGENCY STATION MODEL BNG-1F WHEN USING EITHER CROSS-ZONED DETECTION\* OR THE DOUBLE INTERLOCK PREACTION SYSTEM OPTION. THIS STATION ACTIVATES BOTH DETECTION CIRCUITS SIMULTANEOUSLY.

\*NOT PERMITTED IN NEW YORK CITY.  
 \*NOT FM APPROVED.

733FG06

Fig.6

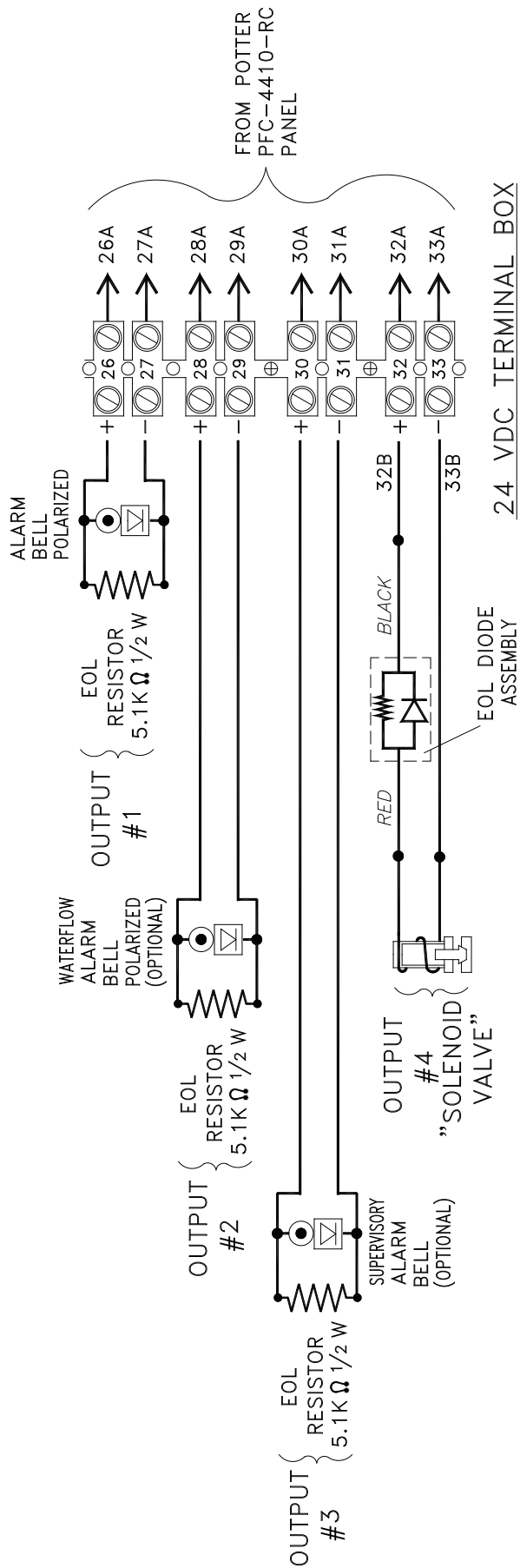

OUTPUT DEVICE CIRCUIT WIRING

733FG07

Figure 7 — Wiring Diagram

## Inspection And Testing Of Single And Double Interlock Systems

Refer to Fig. 8.

1. **Water supply** — Verify that the valve controlling water supply to the deluge valve is opened fully and properly monitored.
2. **Alarm line** — Verify that valve C is opened and remains in this position.
3. **Other trimming valves** — Verify that valve A is open as well as all of the pressure gauge's ¼" 3-way valves. Valves D, E, and H should be closed.
4. **Ball drip valve F** — Push in on the plunger to be sure the ball check is off its seat. If no water appears, the deluge valve's water seat is tight. Inspect the bleed hole in the front of the Model DDX Deluge Valve for leakage.
5. **System pneumatic pressure** — Verify that system air pressure is between 7 and 10 psi (0,5 bar 0,7 bar). Check the Pressure Maintenance Device for leakage and proper pressure.
6. **Releasing device** — Check the outlet of the releasing device (i.e., solenoid valve or the Model B Manual Emergency Station, valve D) for leakage. Also verify that tubing drain lines from releasing devices are not pinched or crushed which could prevent proper releasing of the deluge valve.
7. **Testing alarms** — Open valve E permitting water from the supply to flow to the alarm pressure switch and to the mechanical sprinkler alarm (if present). After testing, close this valve completely. Push in on the plunger of ball drip valve F until all of the water has drained from the alarm line.
8. **Operational test** — Open the Model B Manual Emergency Station, valve D only, OR, operate the solenoid valve by electrical actuation. This is done by operating a detector or an electric manual emergency station. Double interlock systems also require that the sprinkler system's air pressure be discharged, through the inspectors test station or other venting means, below 4 psi (0,3 bar) before total system operation will occur. **Note:** An operational test will cause the Deluge Valve to open and flow water into the sprinkler system.
9. Secure the Model B Manual Emergency Station, valve D, in the OFF position with a nylon tie (included with the assembly) after the deluge valve is reset.

## Testing The Model DDX PrePaK Without Causing Water Flow

Refer to Fig. 8.

1. Close the main valve controlling water supply to the deluge valve and open drain valve B.
2. Verify that valve A is open, allowing water to enter the push-rod chamber.
3. Operate the detection system - Operate a cross-zoned releasing control panel by operating two detectors. For double interlock applications, close valve J and open valve H. Doing so will discharge the sprinkler system's air pressure.
4. Step #3 should result in a sudden drop of water pressure in the deluge valve's push-rod chamber via an energized solenoid valve.
5. Reset the detection system - Reverse the detection system operations performed in Step #3 above. **Note:** All detection devices must be reset before the Potter PFC-4410-RC Releasing Control Panel can be reset.
6. Proceed according to the directions listed in the "Resetting Single And Double Interlock Systems" section of this bulletin.

## Draining Excess/Condensate Water From The System

Refer to Fig. 8.

1. Close the main valve controlling water supply to the deluge valve. Also, close valve A and open the main drain valve, valve B.
2. Open the condensate drain valve, valve H, until all of the water (if any) drains completely. **Note:** Be sure not to keep valve H open for an extended period of time because that will cause enough system air to bleed off, thereby activating the system pressure switch and causing an potentially undesirable alarm condition.
3. Close the main drain valve B. Allow the system's air pressure to return to its previous level. Open valve A first, and then open the main valve controlling the water supply to the deluge valve.

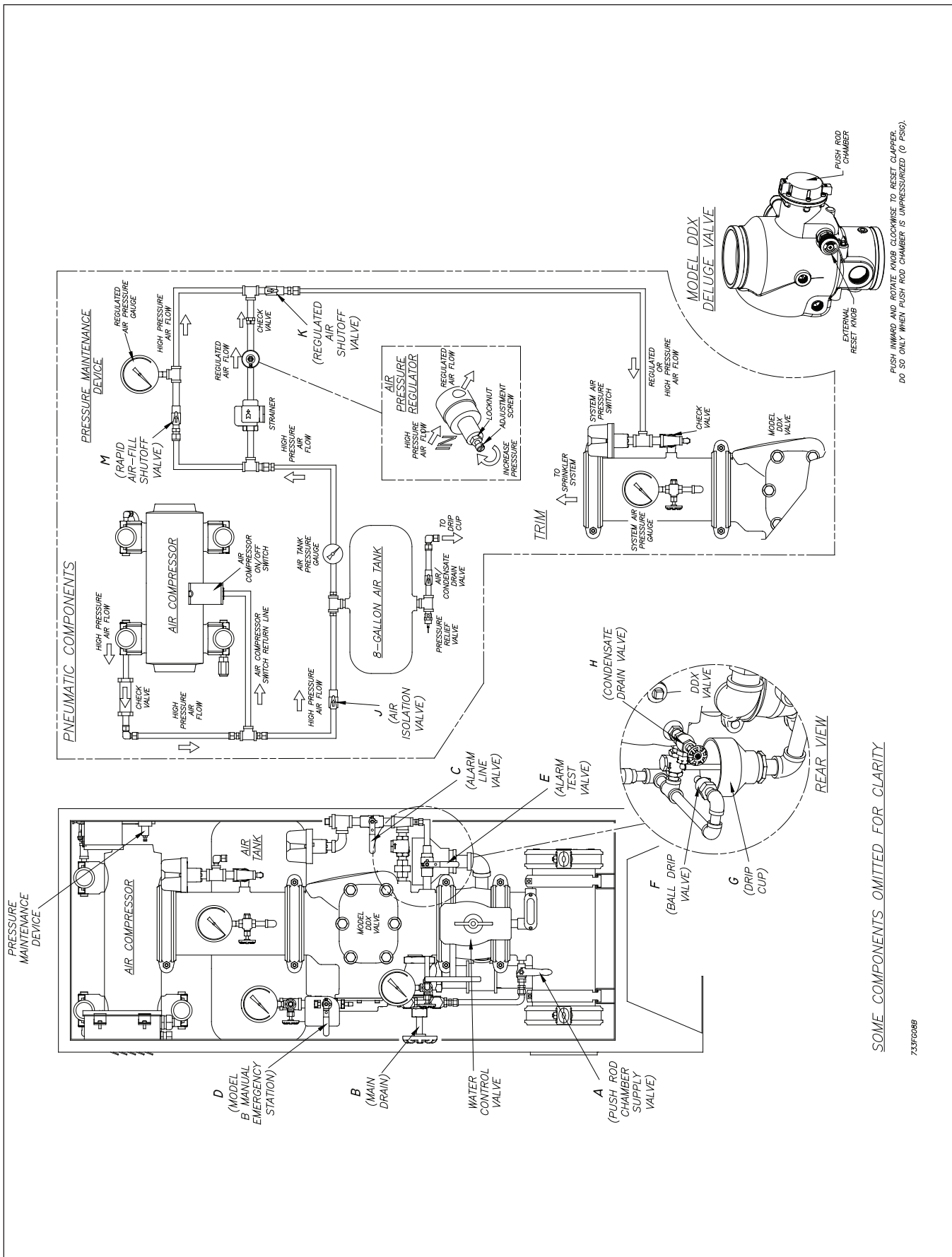

Fig. 8

## **Potter Program #6**

### **Single Interlock Programming Instructions (Single Hazard; 2 Alarm Zones, 1 Waterflow Zone, and 2 Supervisory Zones)**

1. Apply power to panel.
2. Slide the program switch down.
3. Press the FUNCTION button until the display reads "PASSWORD=000."
4. To enter a password, press the SELECT button until the proper number is displayed above the "^" symbol; then press the SET button to move to the next digit. After entering the third number the display will change. (All panels are shipped with a "000" password.)
5. Press the FUNCTION button until the display reads "PROGRAM ##." (the second "#" character refers to the current program number between "0" and "24").
6. Press the SELECT button until the display reads "PROGRAM #6."
7. Press the SET button
8. The panel is completely programmed except for the custom banner and zone messages. Slide the program switch back up.

## **POTTER PROGRAM #6**

OUTPUTS	ZONES				
	*Supervisory 2	#1 Conventional	#2 Manual Release	#3 Waterflow	#4 Low Air Supervisory
#1 ALARM		X	X		
#2 WATERFLOW				X	
#3 SUPERVISORY	X				X
#4 RELEASE		X	X		

INPUTS: 1 conventional zone, 1 manual release zone, 1 waterflow zone, 1 low air zone, 1 supervisory zone.

OUTPUTS: 1 general alarm bell, 1 waterflow bell, 1 supervisory bell, 1 solenoid release circuit.

OPERATION: Activation of either the conventional zone or the manual release will operate the solenoid release circuit and the general alarm bell. Activation of the waterflow zone will operate the waterflow bell. Activation of either the low air zone or the supervisory zone will operate the supervisory bell. When either Zone #1 or #2 is in alarm, Output #1 (general alarm) and Output #4 (solenoid release) will operate. When Zone #3 is in alarm, Output #2 (waterflow bell) will operate. When either Zone #4 or the supervisory zone is activated, Output #3 (supervisory bell) will operate.

**\* The Butterfly valve in the PrePaK assembly is connected to Supervisory 2 input of the Potter PFC-4410RC Releasing/Control panel**

**Refer to the "Installation, Operation and Instruction Manual" for the PFC-4410-RC Releasing Control Panel for Additional Information.**

# POTTER PROGRAM #6 WIRING DIAGRAM

## SINGLE HAZARD, 2 ALARM ZONES 1 WATERFLOW ZONE AND 2 SUPERVISORY ZONES

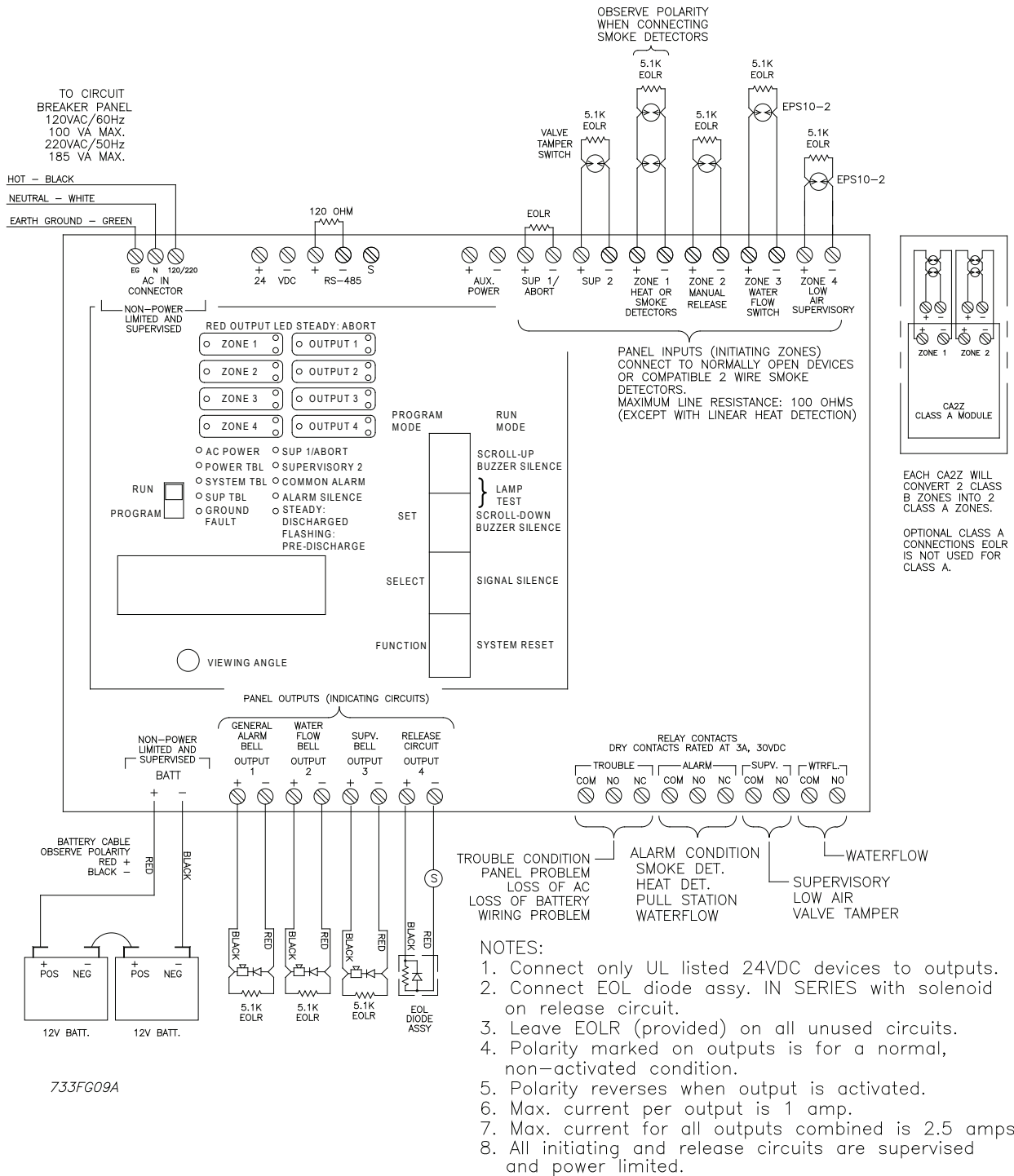

Figure 9 — Wiring Diagram

## **Potter Program #7**

### **Single Interlock Programming Instructions (Single Hazard - Cross-Zoned, 2 Alarm Zones, 1 Waterflow Zone and 2 Supervisory Zones)**

1. Apply power to panel.
2. Slide the program switch down.
3. Press the FUNCTION button until the display reads "PASSWORD = 000."
4. To enter a password, press the SELECT button until the proper number is displayed above the "^" symbol; then press the SET button to move to the next digit. After entering the third number the display will change. (All panels are shipped with a "000" password).
5. Press the FUNCTION button until the display reads "PROGRAM ##." (the second "#" character refers to the current program number between "0" and "24").
6. Press the SELECT button until the display reads "PROGRAM #7."
7. Press the SET button.
8. The panel is completely programmed except for the custom banner and zone messages. Slide the program switch back up.

## **POTTER PROGRAM #7**

OUTPUTS	ZONES				
	*Supervisory 2	#1 Conventional	#2 Conventional	#3 Waterflow	#4 Low Air Supervisory
#1 ALARM		X	X		
#2 WATERFLOW				X	
#3 SUPERVISORY	X				X
#4 RELEASE		X	X		

INPUTS: 2 conventional zones (cross-zoned), 1 waterflow zone, 1 low air zone, 1 supervisory zone.

OUTPUTS: 1 general alarm bell, 1 waterflow bell, 1 supervisory bell, 1 solenoid release circuit.

OPERATION: Activation of both conventional zones at the same time will operate the solenoid release circuit and the general alarm bell. Activation of either conventional zone will operate the general alarm bell. Activation of the waterflow zone will operate the waterflow bell. Activation of either the low air zone or the supervisory zone will operate the supervisory bell. When either Zone #1 or #2 is in alarm, Output #1 (general alarm) will operate. When Zones #1 and #2 are in alarm at the same time, Output #4 (solenoid release) and Output #1 (general alarm) will operate. When Zone #3 is in alarm, Output #2 (waterflow bell) will operate. When either Zone #4 or the supervisory zone is activated, Output #3 (supervisory bell) will operate.

**\* The Butterfly valve in the PrePaK assembly is connected to Supervisory 2 input of the Potter PFC-4410RC Releasing/Control panel.**

**Refer to the "Installation, Operation and Instruction Manual" for the PFC-4410-RC Releasing Control Panel for Additional Information.**

# POTTER PROGRAM #7 WIRING DIAGRAM

SINGLE HAZARD, CROSS ZONED, 2 ALARM ZONES  
1 WATERFLOW ZONE AND 2 SUPERVISORY ZONES

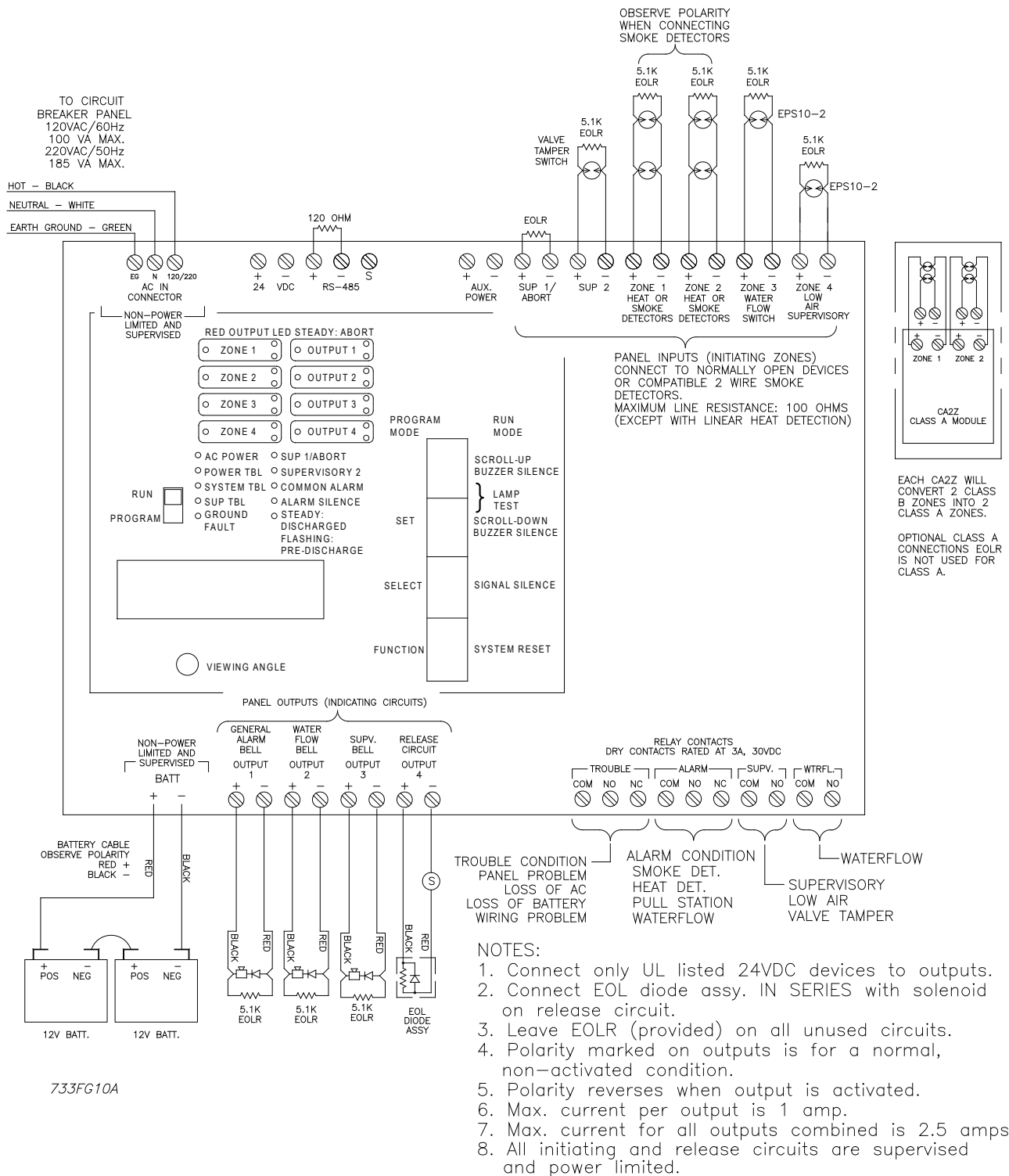

Fig. 10

## Potter Program #9

### Double Interlock Programming Instructions (Single Hazard, Cross Zoned, 2 Alarm Zones (1 Detection & 1 Low Air), 1 Waterflow Zone, and 1 Supervisory Zone)

1. Apply power to the panel.
2. Slide program switch down.
3. Press the FUNCTION button until display reads "PASSWORD=000."
4. To enter a password, press the SELECT button until the proper number is displayed above the "^" symbol; then press the SET button to move to the next digit. After entering the third number, the display will change. (All panels are shipped with a "000" password).
5. Press the FUNCTION button until the display reads "PROGRAM ##." (the second "#" character refers to the current program number between "0" and "24").
6. Press the SELECT button until the display reads "PROGRAM #9."
7. Press the SET button.
8. The panel is completely programmed except for the custom banner and zone messages. Slide the program switch back up.

## POTTER PROGRAM #9

OUTPUTS	ZONES				
	*Supervisory 2	#1 Conventional	#2 Low Air Supervisory (Empty)	#3 Waterflow	#4 Low Air Alarm
#1 ALARM		X			
#2 WATERFLOW				X	
#3 SUPERVISORY	X		X		X
#4 RELEASE		X			X

INPUTS: 1 supervisory zone, 1 conventional detection zone, 1 low air supervisory zone, 1 waterflow zone, 1 low air alarm zone.

OUTPUTS: 1 general alarm, 1 supervisory, 1 waterflow, 1 solenoid release circuit.

OPERATION: Activation of the conventional detection zone and the low air alarm zone at the same time will operate the solenoid release circuit and the general alarm bell.

Activation of the conventional zone only will operate the general alarm output.

Activation of the low air supervisory zone will operate the supervisory bell output.

Activation of the waterflow zone will operate the waterflow bell output.

Activation of the low air alarm zone will operate the supervisory bell output. It will not operate the alarm relay.

When Zone #1 is in alarm, Output #1 will operate.

When Zone #2 is activated, Output #3 will operate.

When Zone #3 is in alarm, Output #2 will operate.

When Zone #4 is activated, Output #3 will operate. This will create a supervisory condition not an alarm condition. The alarm relay will not operate, the supervisory relay will.

When both Zones #1 and #4 are activated at the same time, the solenoid circuit will operate.

**\* The Butterfly valve in the PrePaK assembly is connected to Supervisory 2 input of the Potter PFC-4410RC Releasing/Control panel.**

**Refer to the "Installation, Operation and Instruction Manual" for the PFC-4410-RC Releasing Control Panel for Additional Information.**

# POTTER PROGRAM #9 WIRING DIAGRAM

DOUBLE INTERLOCK, CROSS ZONED, 2 ALARM ZONES  
1 WATERFLOW ZONE AND 1 SUPERVISORY ZONE

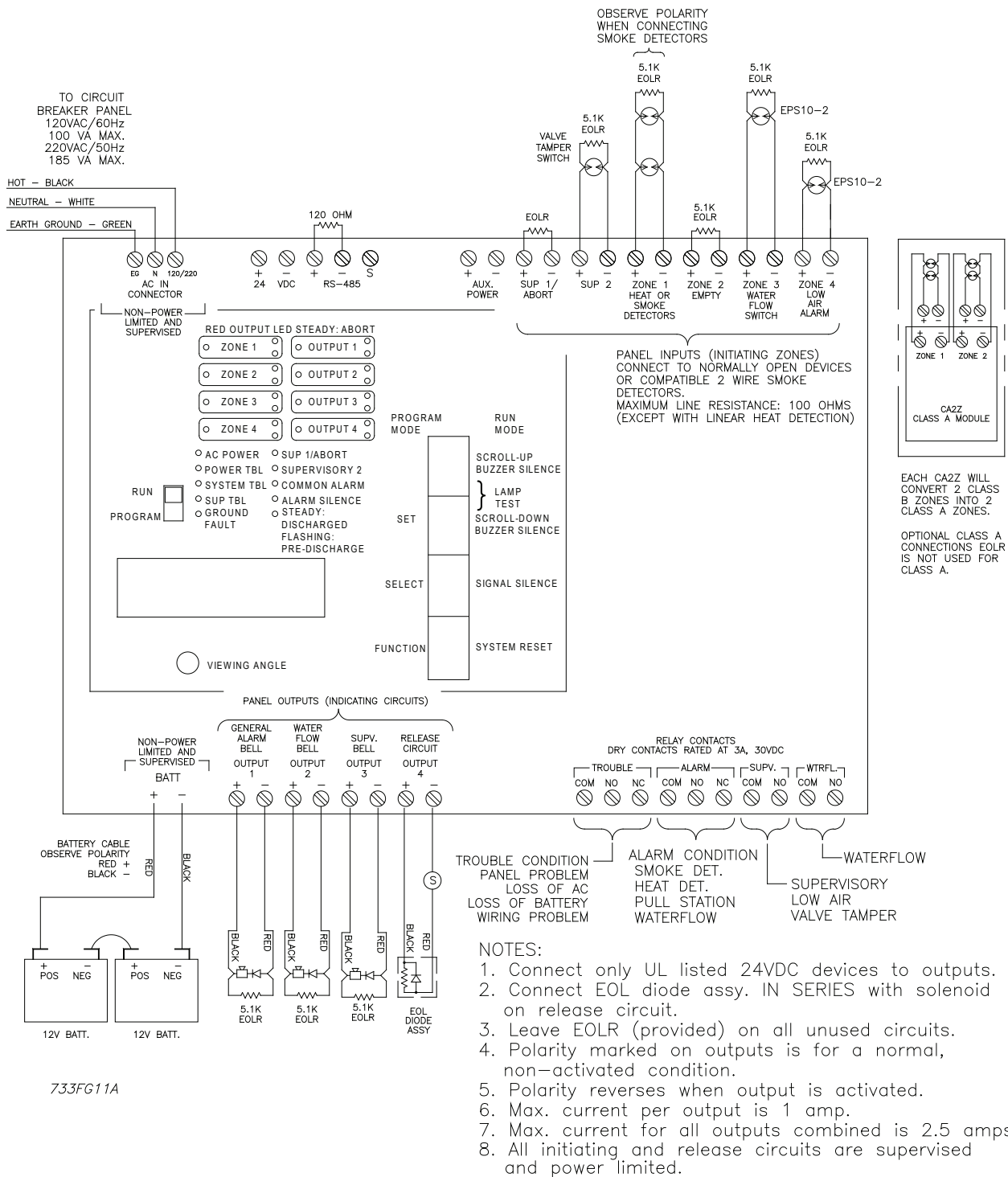

Fig. 11

## Potter Program #10

### Double Interlock Programming Instructions (Single Hazard, Cross Zoned, 3 Alarm Zones (2 Detection & 1 Low Air), 1 Waterflow Zone, and 1 Supervisory Zone)

1. Apply power to the panel.
2. Slide program switch down.
3. Press the FUNCTION button until the display reads "PASSWORD=000."
4. To enter a password, press the SELECT button until the proper number is displayed above the "^" symbol, then press the SET button to move to the next digit. After entering the third number the display will change. (All panels are shipped with a "000" password).
5. Press the FUNCTION button until the display reads "PROGRAM ##." (the second "#" character refers to the current program number between "0" and "24").
6. Press the SELECT button until the display reads "PROGRAM #10."
7. Press the SET button.
8. The panel is completely programmed except for the custom banner and zone messages. Slide the program switch back up.

## POTTER PROGRAM #10

OUTPUTS	ZONES				
	*Supervisory 2	#1 Conventional	#2 Conventional	#3 Waterflow	#4 Low Air Alarm
#1 ALARM		X	X		
#2 WATERFLOW				X	
#3 SUPERVISORY	X				X
#4 RELEASE		X	X		X

INPUTS: 1 supervisory zone, 2 conventional detection zones, 1 waterflow zone, and 1 low air alarm zone.

OUTPUTS: 1 general alarm, 1 supervisory, 1 waterflow, and 1 solenoid release circuit.

OPERATION: Activation of both conventional zones and the low air alarm zone at the same time will operate the solenoid release circuit and the general alarm bell.

Activation of either conventional zone only will operate the general alarm output.

Activation of the waterflow zone will operate the waterflow bell output.

Activation of the low air alarm zone will operate the supervisory bell output. It will not operate the alarm relay.

When either Zone #1 or #2 is in alarm, Output #1 will operate.

When Zone #3 is in alarm, Output #2 will operate.

When Zone #4 is activated, Output #3 will operate. This will create a supervisory condition not an alarm condition. The alarm relay will not operate, the supervisory relay will.

When Zones #1, #2 and #4 are activated at the same time, the solenoid release circuit will operate.

**\* The Butterfly valve in the PrePaK assembly is connected to Supervisory 2 input of the Potter PFC-4410RC Releasing/Control panel.**

**Refer to the "Installation, Operation and Instruction Manual" for the PFC-4410-RC Releasing Control Panel for Additional Information.**

# POTTER PROGRAM #10 WIRING DIAGRAM

DOUBLE INTERLOCK, CROSS ZONED, 3 ALARM ZONES  
1 WATERFLOW ZONE AND 1 SUPERVISORY ZONE

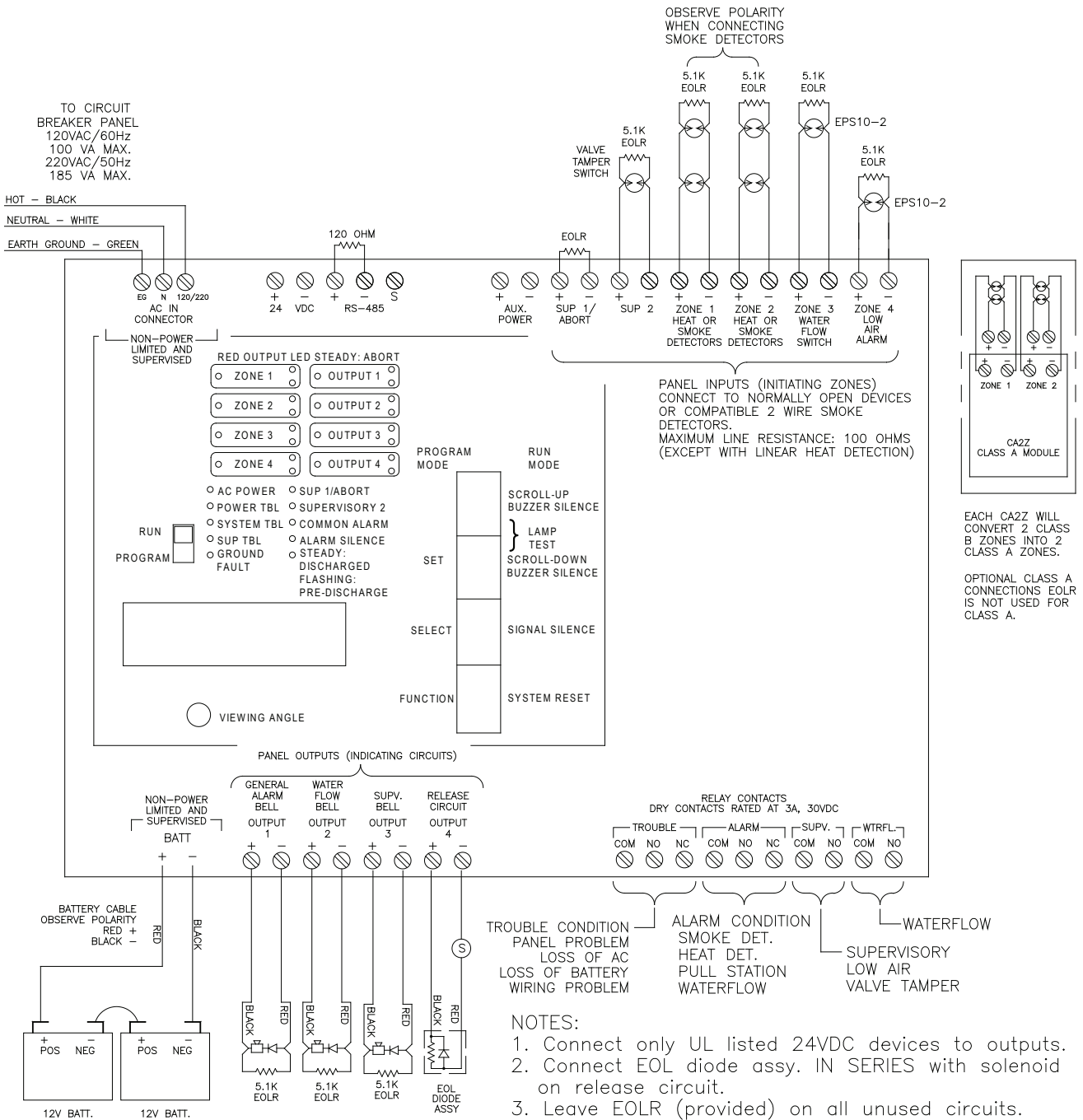

733FG12A

Fig.12

## **Custom Program #1**

**(For New York City Compliance)**

### **Single Interlock Programming Instructions for New York City Compliance (Single Hazard, 2 Alarm Zones, 1 Waterflow Zone, and 2 Supervisory Zones)**

1. Apply power to the panel.
2. Slide the program switch down.
3. Press the FUNCTION button until the display reads "PASSWORD=000."
4. To enter a password, press the SELECT button until the proper number is displayed above the "^" symbol; then press the SET button to move to the next digit. After entering the third number, the display will change (All panels are shipped with a "000" password).
5. Press the FUNCTION button until the display reads "PROGRAM ##" (the second "#" character refers to the current program number between "0" and "24").
6. Press the SELECT button until the display reads "PROGRAM #6."
7. Press the SET button.
8. Slide the program switch up.
9. Slide the program switch down.
10. Apply steps 3 to 5.
11. Press the SELECT button until the display reads "PROGRAM #0."
12. Press the SET button.
13. Press the FUNCTION button until the display reads "OUTPUT 1: INDICATING."
14. Press the SET button until the display reads "OUTPUT #2: INDICATING."
15. Press the SELECT button until the display reads "TROUBLE BELL." Press the SET button.
16. Press the FUNCTION button until the display reads "ZONE 1 OUTPUTS." The "v" is pointing to the first available output for the zone indicated on the display. If the number is displayed, it is turned on for that zone. If the number is not displayed, the zone is turned off.
17. Press the FUNCTION button until the display reads "ZONE 3 OUTPUTS."
18. Press the SELECT button. The "1" should appear under the "v".
19. Press the SET button twice. The panel is completely programmed except for the custom banner and zone messages. If these messages are not desired, then slide the program switch back up.

## **POTTER PROGRAM #1**

OUTPUTS	ZONES				
	*Supervisory 2	#1 Conventional	#2 Manual release	#3 Waterflow	#4 Low Air Supervisory
#1 ALARM		X	X	X	
#2 TROUBLE					
#3 SUPERVISORY	X				X
#4 RELEASE		X	X		

INPUTS: 1 conventional zones, 1 manual release zone, 1 waterflow zone, 1 low air zone, 1 supervisory zone.

OUTPUTS: 1 general alarm bell, 1 trouble bell, 1 supervisory bell, and 1 solenoid release circuit.

OPERATION: Activation of either the conventional zone or the manual release will operate the solenoid release circuit and the general alarm bell.

Activation of the waterflow zone will operate the general alarm bell.

Activation of either the low air zone or the supervisory zone will operate the supervisory bell.

A trouble condition (low battery, wiring problem, etc.) will operate the trouble bell.

When either Zone #1 or #2 is in alarm, Output #1 (general alarm) and Output #4 (solenoid release) will operate.

When Zone #3 is in alarm, Output #1 (alarm bell) will operate.

When either Zone #4 or the supervisory zone is activated, Output #3 (supervisory bell) will operate.

When the panel is in a trouble condition, Output # 2 (trouble bell) will operate.

**\* The Butterfly valve in the PrePaK assembly is connected to Supervisory 2 input of the Potter PFC-4410RC Releasing/Control panel.**

**Refer to the "Installation, Operation and Instruction Manual" for the PFC-4410-RC Releasing Control Panel for Additional Information.**

# CUSTOM PROGRAM #1

## WIRING DIAGRAM FOR NEW YORK CITY COMPLIANCE

### SINGLE INTERLOCK, 2 ALARM ZONES

### 1 WATERFLOW ZONE AND 2 SUPERVISORY ZONES

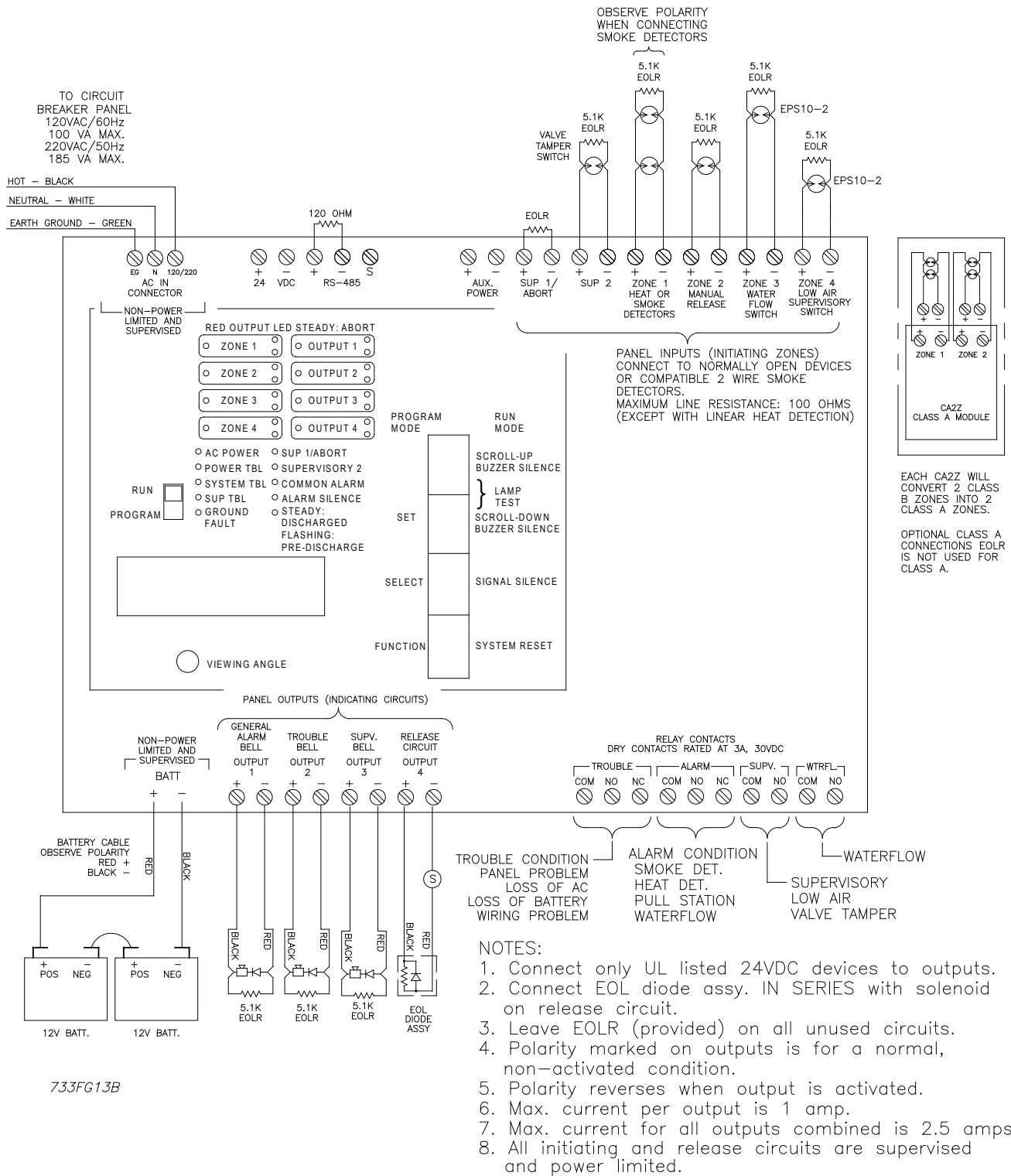
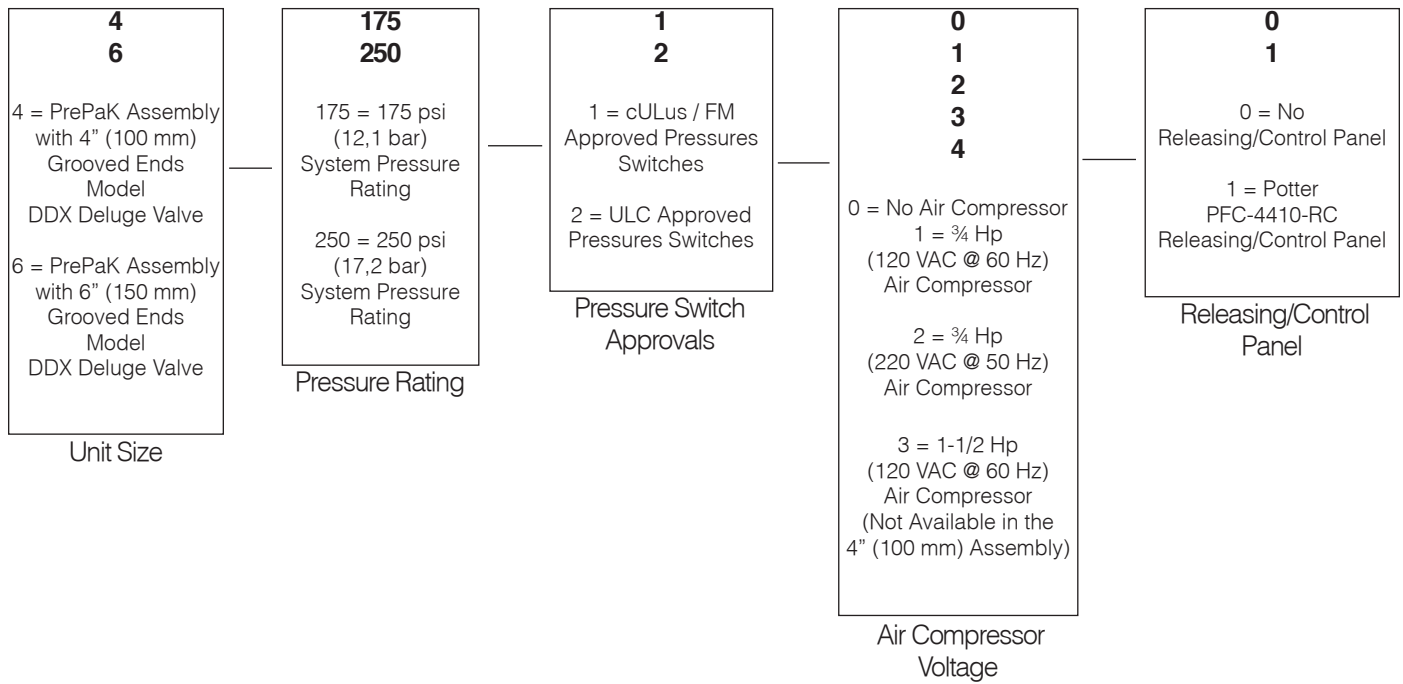

Fig.13

**Ordering Information:**

**Model DDX 4" (100mm) & 6" (150mm) PrePAK Part Number Code Key**



**Example: 4 - 175 - 1 - 1 - 1**

4" (100 mm) Model DDX PrePaK Assembly with 175 psi (12,1 bar) System Pressure Rating, cULus / FM Approved Pressure Switches, ¾ Hp Air Compressor Factory Wired to 120 VAC @ 60 Hz, and Potter PFC-4410-RC Releasing/Control Panel.

## **SOLENOID VALVE INSPECTIONS, TESTS AND MAINTENANCE**

**WARNING: THE OWNER IS RESPONSIBLE FOR MAINTAINING THE FIRE PROTECTION SYSTEM IN PROPER OPERATING CONDITION. ANY SYSTEM MAINTENANCE OR TESTING THAT INVOLVES PLACING A CONTROL VALVE OR DETECTION SYSTEM OUT OF SERVICE MAY ELIMINATE THE FIRE PROTECTION OF THAT SYSTEM. PRIOR TO PROCEEDING, NOTIFY ALL AUTHORITIES HAVING JURISDICTION. CONSIDERATION SHOULD BE GIVEN TO EMPLOYMENT OF A FIRE PATROL IN THE AFFECTED AREA.**

**WARNING: PRIOR TO OPERATING THE SOLENOID VALVE, BE SURE TO CLOSE THE SYSTEM CONTROL VALVE TO AVOID UNINTENTIONAL OPERATION OF THE DELUGE VALVE**

1. Inspections: It is imperative that the system be inspected and tested in accordance with NFPA 25 on a regular basis. The frequency of the inspections may vary due to contaminated water supplies, corrosive water supplies, or corrosive atmospheres. In addition, the alarm devices, detection systems, or other connected trim may require a more frequent schedule. Refer to the system description and applicable codes for minimum requirements.
2. The valve must be inspected at least monthly for cracks, corrosion, leakage, etc., and cleaned, repaired, or replaced, or replaced as necessary.
3. If leakage is suspected through the solenoid valve, the valve diaphragms and seats should be inspected and if necessary, repaired or replaced.

**WARNING: CLOSE SYSTEM CONTROL VALVE, TURN OFF POWER SUPPLY, AND DEPRESSURIZE VALVE BEFORE DISASSEMBLING VALVE. IT IS NOT NECESSARY TO REMOVE THE VALVE FROM THE PIPE LINE TO MAKE INSPECTIONS.**

4. When lubricating valve components, use high grade silicone grease (Dow Corning® 111 Compound Lubricant or equal).
5. When reassembling, tighten parts to torque values indicated in the manufacturer's maintenance instructions (packed with valve).
6. After maintenance is completed, operate the valve a few times to be sure of proper operation. A metallic "click" signifies the solenoid is operating.
7. All service must be performed by qualified personnel. Upon completion of inspections or replacement of the valve, the entire system must be checked for proper operation. See appropriate system description and testing instructions for additional information.

---

The equipment presented in this bulletin is to be installed in accordance with the latest published Standards of the National Fire Protection Association, Factory Mutual Research Corporation, or other similar organizations and also with the provisions of governmental codes or ordinances whenever applicable.

Products manufactured and distributed by Reliable have been protecting life and property for over 90 years, and are installed and serviced by the most highly qualified and reputable sprinkler contractors located throughout the United States, Canada and foreign countries.

---

Manufactured by

**Reliable®**

The Reliable Automatic Sprinkler Co., Inc.  
(800) 431-1588 Sales Offices  
(800) 848-6051 Sales Fax  
(914) 829-2042 Corporate Offices  
www.reliablesprinkler.com Internet Address



Revision lines indicate updated or new data.

EG. Printed in U.S.A 12/10 P/N 9999970306