

Reliable®

Dry Pilot Line Single Interlock Preaction System 4"(100mm), 6"(150mm) & 165mm Sizes

Bulletin 732 Rev. D

Instructions for Installation, Operation, Care, and Maintenance

- 12 to 26 psi (0,8 to 1,8 bar)
Pneumatic Pressure
- Externally Resettable Clapper
- One Main Drain

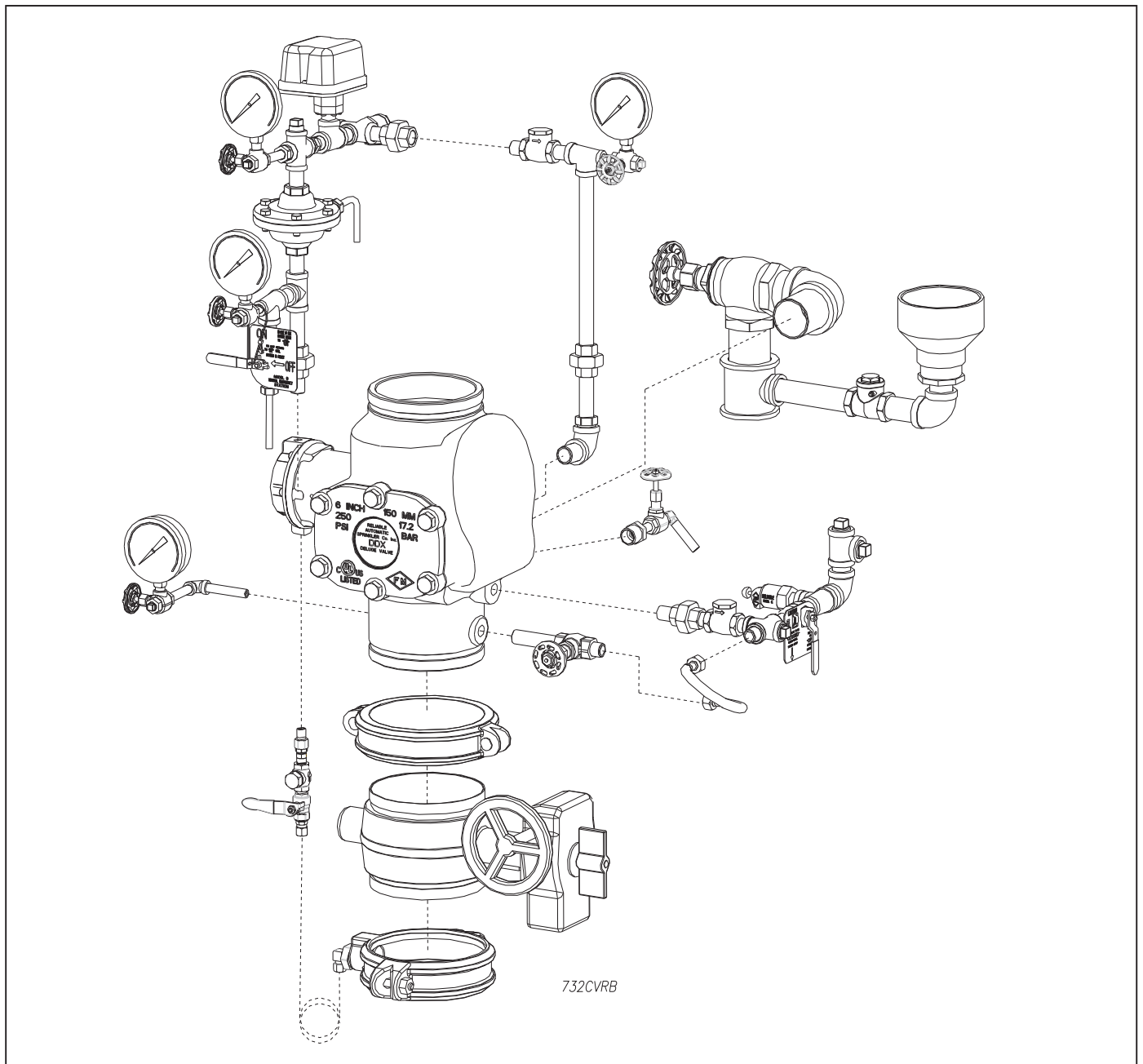

General Description

Single Interlock Dry Pilot Line Preaction Systems are designed for water-sensitive areas that require protection from inadvertent water flow into the sprinkler system piping. Dry pilot operation is used in areas that may be subjected to freezing conditions. They can also be utilized to obtain installed sprinkler heights and pipe lengths greater than allowed for wet pilot systems. A dry pilot line installation consists of an air-pressurized line of closed sprinklers or pilot line detectors (Reliable's Model F1-FTR), which are located in the area to be protected. NFPA 72 or the Authority Having Jurisdiction (AHJ) should be consulted for spacing and elevation requirements for the installation of dry pilot sprinklers/detectors.

In the system's trim, the dry pilot line is connected to a Model LP Dry Pilot Line Actuator. This actuator functions very much like a miniature dry pipe valve. It requires only 12 to 26 psi (0,8 to 1,8 bar) of air pressure (depending on the water supply pressure) to maintain the Model DDX Deluge Valve in a closed position. In areas where moisture-laden air could cause a freezing condition, or other problems in the dry pilot line, the use of a dry, compressed gas such as nitrogen is suggested. Approved gas handling regulators (see Reliable Bulletin 251) and connections are recommended. When one of the dry pilot line sprinklers/detectors actuates, the air pressure in the line is reduced, thus opening the Model LP Dry Pilot Line Actuator, which in turn releases the DDX Deluge Valve and fills the fire sprinkler piping with water. However, water does not flow from the fire sprinkler system until one of its sprinklers fuses from the heat of the fire.

The fire sprinkler system piping may be required to be supervised (see NFPA 13) with air pressure. Loss of this supervisory air due to a damaged sprinkler or the sprinkler piping will not cause the Model DDX Deluge Valve to open. This is accomplished by the ½" check valve which is located in the valve's trim. The check valve prevents air pressure (from the dry pilot line) from escaping out of the Model LP Dry Pilot Line Actuator. A low air pressure switch (System Sensor EPS40-2 or EPSA40-2) is also provided in the trim. The contacts of this switch will close on the loss of air in the sprinkler piping, thereby providing a low air alarm to aid in insuring the integrity of the sprinkler system piping. The pressure switch's low air alarm should be wired to a supervisory alarm bell or the building's alarm system (Note: the wiring for a closing of the contacts on the loss of air are the "Common" and "B" contacts). Damage that causes a loss of air pressure to a dry pilot line sprinkler/detector or the dry pilot line piping will cause the Model DDX Deluge Valve to open, flowing water into the fire sprinkler system piping. The supervisory air supply for both the dry pilot line and the fire sprinkler piping can effectively be supervised by means of pressure switch operated, tank-mounted air compressor and a Reliable Model A-2 Pressure Maintenance Device (see Reliable Bulletins 250 & 251). The compressor's tank provides a reserve supply of air, whereas the Model A-2 Pressure Maintenance Device consistently regulates the air pressure of both the dry pilot line and the fire sprinkler piping.

The dry pilot line sprinklers/detectors must be more sensitive to the heat from a fire than the sprinklers in the fire sprinkler system. The Model F1-FTR (Fixed Temperature Release) is specifically designed for use in dry pilot line operated sprinkler systems. Dry pilot line sprinklers are detection devices and do not provide any water to aid in the firefighting capability of the fire sprinkler system.

To fully operate a dry pilot line preaction system, the heat from a fire must fuse a dry pilot line sprinkler/detector thereby releasing the air pressure from the Model LP Dry Pilot Line Actuator. The water pressure is then able to overcome the pressure differential of the actuator, allowing water to flow from the Model DDX Deluge Valve's push rod chamber. As this water pressure is lost in the push rod chamber, the main water supply will open the deluge valve's clapper flowing water into the fire sprinkler system piping. Water flowing into the system will flow through the intermediate chamber of the deluge valve to a mechanical sprinkler alarm (optional) and/or will simultaneously produce water pressure that causes the transfer of contacts in the (optional) alarm pressure switch mounted in the trim. If provided, the alarm pressure switch can electrically initiate the shut-down or start up of equipment, such as computer, HVAC, or other secondary alarm devices (Note: the wiring contacts for the alarm pressure switch are the "Common" and "A" contacts). The flow of water into the sprinkler system piping converts the dry system into a wet system. In the event that the fire subsequently produces enough heat to operate a fire sprinkler head, water will flow from that sprinkler, controlling or suppressing the fire.

At the heart of Reliable's Dry Pilot Line Single Interlock Preaction System is the Model DDX Deluge Valve. This deluge valve is a hydraulically operated, straight-through-design, differential-type (see Fig. 1). System maintenance is simplified since the deluge valve can be reset externally without removing its cover plate. This feature provides a significant system-restoration time advantage. The Model DDX Deluge Valve has an intermediate chamber and thereby does not require an in-line air check valve. Also, for ease of installation, the deluge valve only requires a single drain connection.

The trim set for the system (see Fig. 2) provides all of the necessary equipment for connections to the Model DDX Deluge Valve's pushrod chamber inlet and outlet ports, the 2" (50mm) main drain, alarm devices, air supply, and required pressure gauges. This trim set is available in individual (loose) parts, in time-saving, segmentally assembled kit forms or fully assembled to the Model DDX Deluge Valve (with or without a control valve).

Listings & Approvals

Reliable's 4" (100mm), 6" (150mm) & 165mm Dry Pilot Line Single Interlock Preaction Systems are Underwriters Laboratories, Inc. Listed and UL certified for Canada (cULus) in the Special System Water Control Valve-Deluge Type (VLFT) category.

The NYC acceptance number for this system is MEA 258-93-E.

Reliable Single Interlock Preaction Systems are UL Listed only when used with the trim components shown in Fig 2.

DDX VALVE CLAPPER IN "OPEN", "CLOSED"
AND "LATCHED" POSITIONS

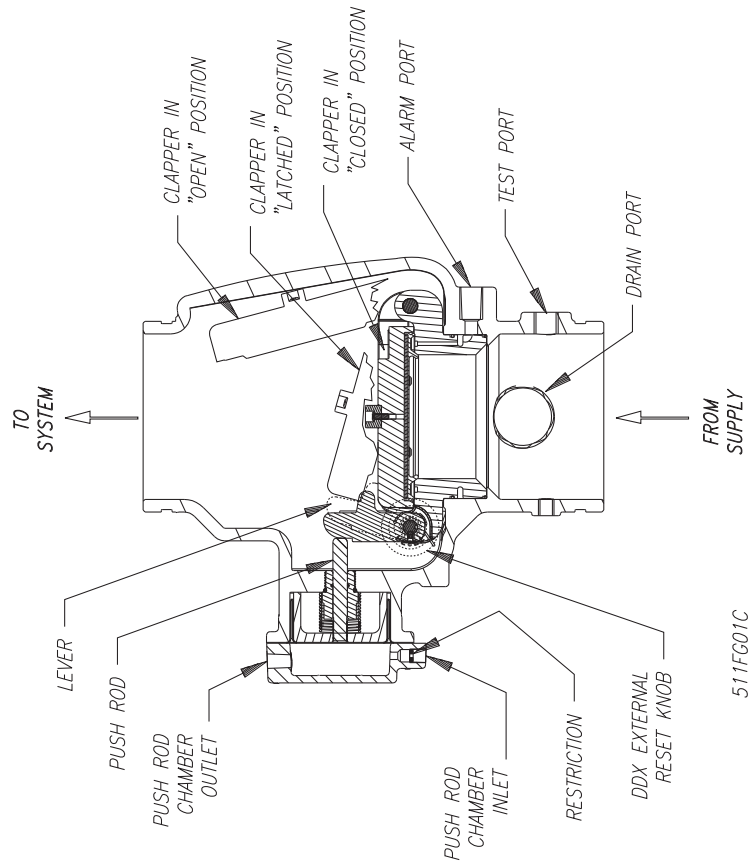

REAR VIEW OF MODEL
DDX DELUGE VALVE

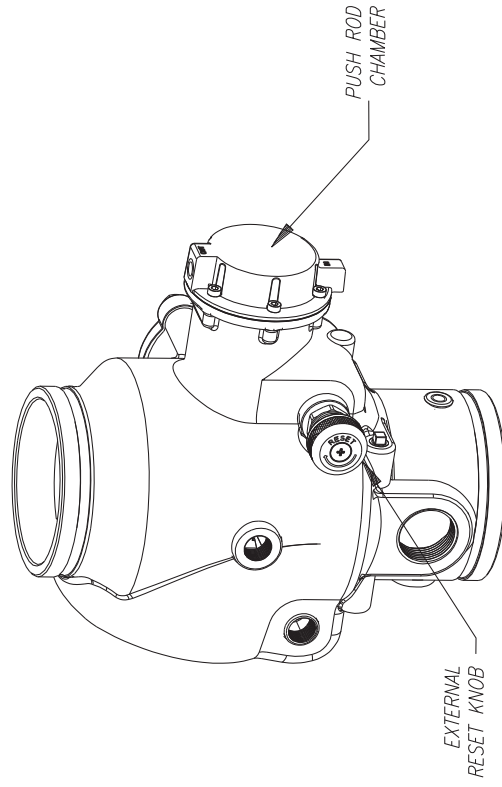

PUSH INWARD AND ROTATE KNOB CLOCKWISE TO RESET CLAPPER.
DO SO ONLY WHEN PUSH ROD CHAMBER IS UNPRESSURIZED (0 PSIG).

Fig. 1

DRY PILOT LINE SINGLE INTERLOCK PREACTION TRIM

CONNECT TO RELIABLE'S
MODEL A-2 PRESSURE
MAINTENANCE DEVICE

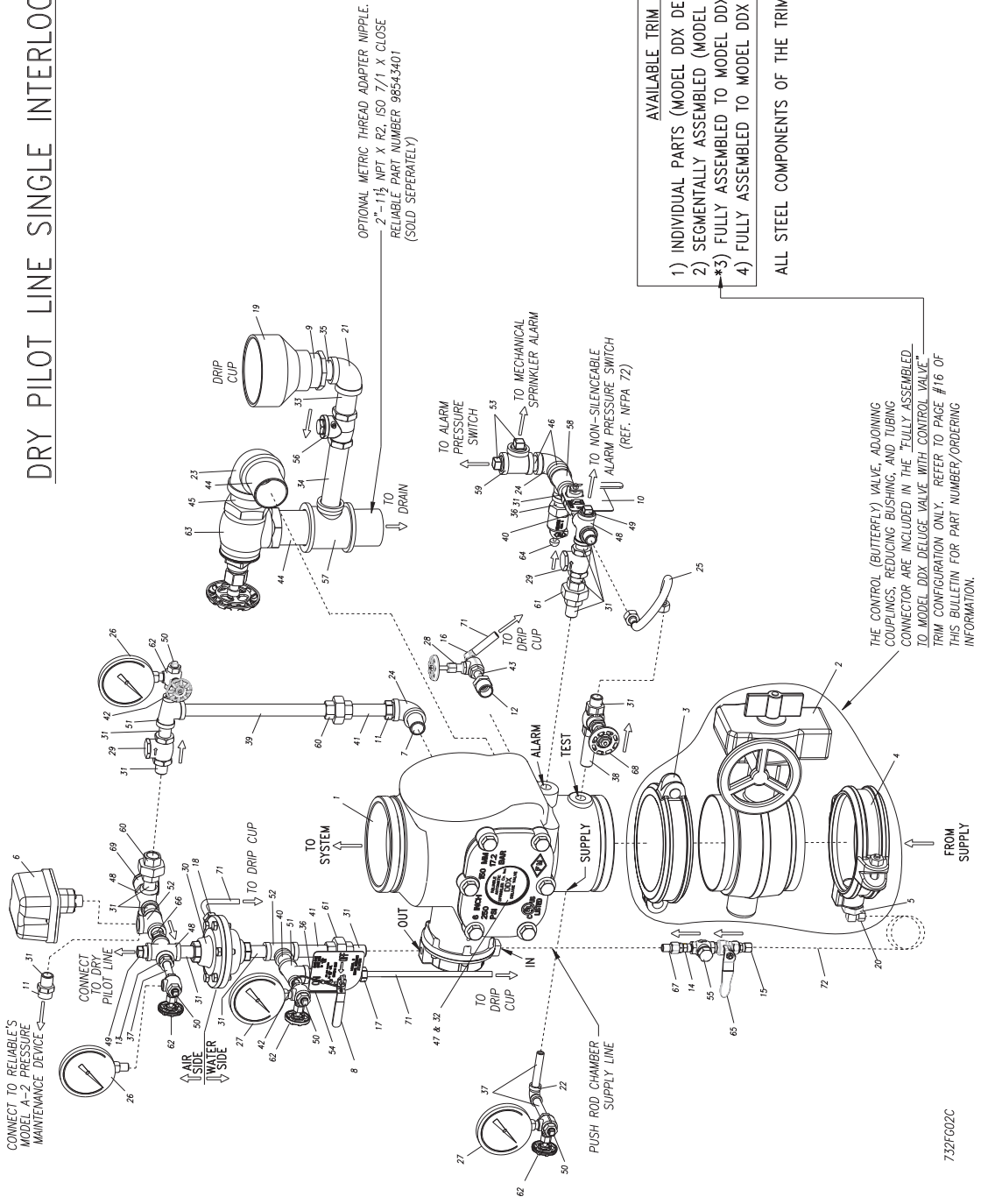

- AVAILABLE TRIM CONFIGURATIONS:**
- 1) INDIVIDUAL PARTS (MODEL DDX DELUGE VALVE SOLD SEPARATELY)
 - 2) SEGMENTALLY ASSEMBLED (MODEL DDX DELUGE VALVE SOLD SEPARATELY)
 - *3) FULLY ASSEMBLED TO MODEL DDX DELUGE VALVE WITH CONTROL VALVE
 - 4) FULLY ASSEMBLED TO MODEL DDX DELUGE VALVE WITHOUT CONTROL VALVE

ALL STEEL COMPONENTS OF THE TRIM ASSEMBLIES ARE GALVANIZED

THE CONTROL (BUTTERFLY) VALVE, ADJOINING COUPLINGS, REDUCING BUSHING, AND TUBING CONNECTOR ARE INCLUDED IN THE "FULLY ASSEMBLED TO MODEL DDX DELUGE VALVE WITH CONTROL VALVE" TRIM CONFIGURATION ONLY. REFER TO PAGE #16 OF THIS BULLETIN FOR PART NUMBER/ORDERING INFORMATION.

732FG02C

Fig. 2

Dry Pilot Line Single Interlock Preaction Trim Parts List (Refer to Fig. 2)

Item No.	Part No.	Description	Qty.
1	6103060024	Assembly, Valve, 6" (150mm) For 6" Ass'y Only	1
	6103040026	Assembly, Valve, 4" (100mm) For 4" Ass'y Only	
2	6215052400	Wafer-Butterfly Valve, 6" For 6" Ass'y Only	1
	6215051600	Wafer-Butterfly Valve, 4" For 4" Ass'y Only	
3	7g05242400	Coupling, Rigid, 6" For 6" Ass'y Only	1
	7g05161600	Coupling, Rigid, 4" For 4" Ass'y Only	
4	7d05464200	Coupling, Rigid, 6" W/1" Outlet For 6" Ass'y Only	1
	7d05444200	Coupling, Rigid, 4" W/3/4" Npt Outlet For 4" Ass'y Only	
5	98048028	Bushing, Reducer, 1" X 1/4", Galv. For 6" Ass'y Only	1
	98048025	Bushing, Reducer, 3/4" X 1/4", Galv. For 4" Ass'y Only	
6	6999991340	Pressure Switch, Epsa40-2 (UL/FM)	1
	6999992361	Pressure Switch, Epsa40-2 (ULC)	
7	98543232	Nipple, Steel, Galv., 3/4" X 2" For 6" Ass'y Only	1
	98543233	Nipple, Steel, Galv., 3/4" X 2-1/2" For 4" Ass'y Only	
8	78653000	Assembly, Manual Emergency Station	1
9	98048015	Bushing, Reducer, 2" Spigot X 1" Nptf, Pvc	1
10	78653004	Assembly, Valve Caution Station, 1/2"	1
11	98048022	Bushing, Reducer, 3/4" X 1/2", Galv.	2
12	98048025	Bushing, Reducer, 3/4" X 1/4", Galv.	1
13	98048000	Bushing, Reducer, 1/2" X 1/4", Galv.	1
14	98840147	Check Valve, 1/4" Npt, Poppet Type Inline	1
15	92056702	Connector, 3/8" Tubing X 1/4" Npt	1
16	92056705	Connector, Elbow, 3/8" ID Tube X 1/4" Npt	1
17	92056810	Connector, 3/8" Id Tube X 1/2" Npt	1
18	92056704	Connector, Elbow, 3/8" ID Tube X 1/2" Npt	1
19	98050004	Drain Cup, Pvc	1
20	92056703	Elbow, Male, 3/8" Tube X 1/4" Npt	1
21	98174403	Ell, 1", Mall Iron, Galv.	1
22	98174404	Ell, 1/4", Mall Iron, Galv.	1
23	98174405	Ell, 2", Mall Iron, Galv.	1
24	98174402	Ell, 3/4", Mall Iron, Galv.	2
25	96920912	Flex Line, 12"	1
26	98248000	Gauge, Air Pressure (0-80 Psi)	2
27	98248001	Gauge, Water Pressure (0-300 Psi)	2
28	98840172	Globe Valve, 1/4"	1
29	98840181	Horiz. Swing Check Valve, 1/2" Npt	2
30	71030010	Model Lp Pilot Line Actuator	1
31	98543223	Nipple, Steel, Galv., 1/2" X 1-1/2"	14
32	94616915	Nameplate, Deluge Valve	1
33	98543222	Nipple, Steel, Galv., 1" X 3-1/2"	1
34	98543266	Nipple, Steel, Galv., 1" X 6"	1
35	98543213	Nipple, Steel, Galv., 1" X Close	1
36	98543210	Nipple, Steel, Galv., 1/2" X 2-1/2"	2
37	98543220	Nipple, Steel, Galv., 1/4" X 3"	3
38	98543228	Nipple, Steel, Galv., 1/2" X 4-1/2"	1
39	98543252	Nipple, Steel, Galv., 1/2" X 10-1/2"	1
40	98543209	Nipple, Steel, Galv., 1/2" X 2"	2
41	98543230	Nipple, Steel, Galv., 1/2" X 3"	2
42	98543226	Nipple, Steel, Galv., 1/4" X 1-1/2"	2
43	98543244	Nipple, Steel, Galv., 1/4" X 2"	1
44	98543208	Nipple, Steel, Galv., 2" X 3"	2
45	98543238	Nipple, Steel, Galv., 2" X Close	1
46	98543279	Nipple, Steel, Galv., 3/4" X Close	2
47	99080002	Pad-Adhesive	1

Item No.	Part No.	Description	Qty.
48	98750003	Pipe Cross, 1/2", Galv.	3
49	98604406	Plug, Iron, Sq. Hd., 1/2"	2
50	98614403	Plug, Iron, Sq. Hd., 1/4"	4
51	98761649	Tee, Glvn., 1/2" X 1/4" X 1/2"	2
52	98761651	Tee, Glvn., 1/2"	2
53	98614401	Plug, Iron, Sq. Hd., 3/4"	2
54	89141112	Tie, Retaining	9
55	98727607	Strainer, 1/4"	1
56	98840145	Swing Check Valve, 1" Npt	1
57	96606627	Tee, Glvn. 2" X 2" X 1"	1
58	96606612	Tee, Glvn., 3/4" X 1/2" X 1/2"	1
59	96606601	Tee, Glvn., 3/4"	1
60	98815204	Union, "O" Ring Seal, Galv., 1/2"	2
61	98815200	Union, 1/2", Iron, Galv.	2
62	98840160	Valve, 3-Way, 1/4"	4
63	98840100	Valve, Angle, 2"	1
64	78653100	Valve, Ball Drip, 1/2"	1
65	98840117	Valve, Ball, 1/4" Nptf X 1/4" Nptm	1
66	96816904	Valve, Check, 1/2"	1
67	98840187	Valve, Check, 1/4" Nptf X 1/4" Nptm	1
68	98840171	Valve, Globe, 1/2"	1
69	98840195	Valve, Relief, 1/2", 33 Psi	1
70	----	-----	--
71	96686756	Tubing, Pvc, 3/8" ID X 6 Ft.	1
72	98768008	Copper Tubing, 3/8"	30"

System Operation

To fully operate (discharge water) a Dry Pilot Line Single Interlock Preaction System, two independent events must coexist before water flow will occur. A closed fire sprinkler head and a pilot line detector head must fuse open. Operation of just a fire sprinkler head will only cause a low air alarm to annunciate. The operation of just a pilot line detector head will cause the Model DDX Valve to trip open, but no water will be delivered to the fire until a closed fire sprinkler head is also fused open.

When set correctly for service, the Model DDX Deluge Valve is hydraulically established to withhold the supply water from the sprinkler system piping. The Reliable Model DDX Deluge Valve is shown in both closed and open positions in Fig. 1. In the closed position, the supply pressure acts on the underside of the clapper and also on the push rod through the push rod chamber's inlet restriction. The resultant force due to the supply pressure acting on the push rod is multiplied by the mechanical advantage of the lever and is more than sufficient to hold the clapper closed against normal supply pressure surges.

When a fire is detected, the Model LP Dry Pilot Line Actuator vents the push rod chamber to atmosphere through the chamber's outlet. Since the pressure cannot be replenished through the inlet restriction as rapidly as it is vented, the push rod chamber pressure falls instantaneously. When the push rod chamber pressure approaches approximately one-third of the supply pressure, the upward force of the supply pressure acting beneath the clapper overcomes the lever-applied force thereby opening the clapper.

Once the clapper has opened, the lever acts as a latch, preventing the clapper from returning to the closed position. Water from the supply flows through the Deluge Valve into the system piping. Water also flows through the Deluge Valve alarm outlet to the alarm devices.

After system shutdown, resetting the Model DDX Deluge Valve is quite simple. Doing so only requires pushing in and turning the reset knob at the rear of the valve (see Fig 1). The external reset feature of the Model DDX Deluge Valve provides a means for simple, economical system testing, which is one essential facet of a good maintenance program. The external reset feature does not, however, eliminate another important facet of good maintenance, namely, periodic cleaning and inspection of the internal valve parts.

In the event that water builds up inside the valve due to condensate from the air supply system or water left inside from valve system testing, a drain is available for venting. After closing the main supply valve, a small valve over the drain cup can be opened slightly until the water inside the valve body and the main pipe column has drained. See the section titled "Draining Excess/Condensate Water From System" in this bulletin for the detailed procedure.

The Model B Manual Emergency Station (see Fig. 3) is also included in the Reliable Dry Pilot Line Single Interlock Praction System trim set. It consists of an aluminum nameplate mechanically attached to a ball valve. The valve handle in its OFF position is guarded against accidental turning to the ON position (and system discharge) by a nylon cable tie provided with each trim kit. The cable tie is inserted, as shown in Fig. 3, after the system has been restored for operation. The nylon cable tie is designed to allow, in case of an emergency, forceful turning of the valve handle to the ON position. As an alternative to the Model B Hydraulic Manual Emergency Station, the Model A Hydraulic Manual Emergency Pull Box (see Reliable Bulletin 506) is also available and can be provided as an option.

Whenever ambient temperature conditions are high, the water temperature in the Model DDX Deluge Valve's pushrod chamber could possibly increase, thereby increasing the pressure in the chamber to values exceeding the rated pressure of the system. In an indoor installation where standard room temperatures are exceeded, a pressure relief kit may be needed. Pressure relief kit, P/N 6503050001, can be installed into the pushrod chamber's releasing line to limit the pressure to 175 psi (12,1 bar).

Pressurizing Line Connection

The water supply for the push-rod chamber must be provided by connection of its inlet pressurizing line to the water supply piping. Pressurizing lines for multiple Model DDX Deluge Valve push-rod chambers must never be manifolded together, having only a single tap on the water supply piping. Each Model DDX Deluge Valve must have its own push-rod chamber pressurizing line connection. This connection must be made on the supply side of the main water supply control valve. This can be accomplished by:

- a. Using a tapped connection directly below or next to the main water supply control valve using a welded outlet or the appropriate mechanical fittings. A grooved-end outlet coupling is one way to achieve this (see Fig. 2); or
- b. Using a water supply control valve that has an available threaded (NPT) supply-side tap design to allow for a direct water supply connection to the Model DDX Deluge Valve's push-rod chamber.

Caution: Reliable's DDX valve is designed with an inlet restriction built into the pushrod chamber. It is important not to introduce additional restrictions into the direct water supply connection or the discharge from the pushrod chamber by installing additional valves or improperly installing the copper lines used in the trim of the valve.

Hydrostatic Testing of DDX Valves and DDX Systems

As required by NFPA 13, fire sprinkler systems with working pressures up to and including 150 psi are to be hydrostatically tested at a water pressure of 200 psi and maintain that pressure without loss for two hours. Fire sprinkler systems with working pressures above 150 psi are required to be hydrostatically tested at 50 psi above the system working pressure and maintain that pressure without loss for two hours. In addition to the hydrostatic tests described above, dry pipe and double interlock preaction systems require an additional low pressure air test.

In some cases, hydrostatic testing (in accordance with the NFPA 13 requirements noted above) will result in pressures that exceed the working pressure of the valve and trim kit for the two-hour test period. The valve and applicable trim kit have been tested, approved and listed under these conditions and as such, hydrostatic testing in accordance with NFPA 13 is acceptable. In addition, the clapper can remain in the closed position and the trim kit need not be isolated, as each has been designed to withstand hydrostatic testing as required by NFPA 13.

Hydrostatically testing the valve and trim to pressures higher than their rating is limited to the hydrostatic test as referenced by NFPA 13. It does not address the occurrence(s) of a "water hammer" effect, which can indeed damage the valve. A "water hammer" in the water supply piping of the valve can create pressures in excess of the rated pressure and should be avoided by all necessary means. This condition may be created from improper fire pump settings, underground construction work, or an improper venting of trapped air in the water supply piping.

System Design Considerations

The automatic sprinklers, air compressor, releasing devices, electric releasing control equipment, fire detection devices, manual pull stations, and signaling devices which are utilized with the Dry Pilot Line Single Interlock Praction System must be UL or ULC Listed, as applicable.

The Deluge Valve, and all interconnecting piping must be located in a readily visible and accessible location and in an area that can be maintained at a minimum temperature of 40°F (4°C). **Note:** Heat tracing is not permitted.

Pendent sprinklers, other than dry pendants, used on preaction systems shall be installed on return bends per NFPA 13.

System Air Pressure Requirements

A Reliable Model A-2 Pressure Maintenance Device is used to maintain the pneumatic pressure of both the Dry Pilot Line of detectors and the fire sprinklers to the values shown in Table A. The values listed in the table represent the necessary ranges of pneumatic pressure required to keep the Model LP Dry Pilot Line Actuator in the closed position for a given water supply pressure.

Table A

Water Pressure psi (bar)	Pneumatic Pressure to be Pumped into Sprinkler System, psi (bar)	
	Not Less Than	Not More Than
20 (1,4)	12 (0,8)	16 (1,1)
50 (3,4)		
75 (5,2)	13 (0,9)	17 (1,2)
100 (6,9)	15 (1,0)	19 (1,3)
125 (8,6)	16 (1,1)	20 (1,4)
150 (10,3)	17 (1,2)	21 (1,4)
175 (12,1)	18 (1,2)	22 (1,5)
200 (13,8)	19 (1,3)	23 (1,6)
225 (15,5)	21 (1,5)	25 (1,7)
250 (17,2)	22 (1,5)	26 (1,8)

Note: During system set-up, a higher pneumatic pressure may be required in order to properly set the Model LP Dry Pilot Line Actuator.

Dry Pilot Line Single Interlock Preaction System– Engineering Specifications

General Description

Preaction system shall be a single interlock preaction system utilizing a [4" (100 mm)] [6" (150 mm)] [165mm] [cULus Listed] hydraulically operated, differential latching clapper-type valve with pneumatic release preaction trim. Deluge valve shall be of lightweight, ductile-iron construction with "drop in" bronze seat and clapper assembly. Bronze seat shall have O-ring seals to resist corrosion and leakage. Clapper facing shall be pressure actuated, providing a limited compression seat for the sealing force between the clapper rubber facing and the valve seat. Push-rod cham-

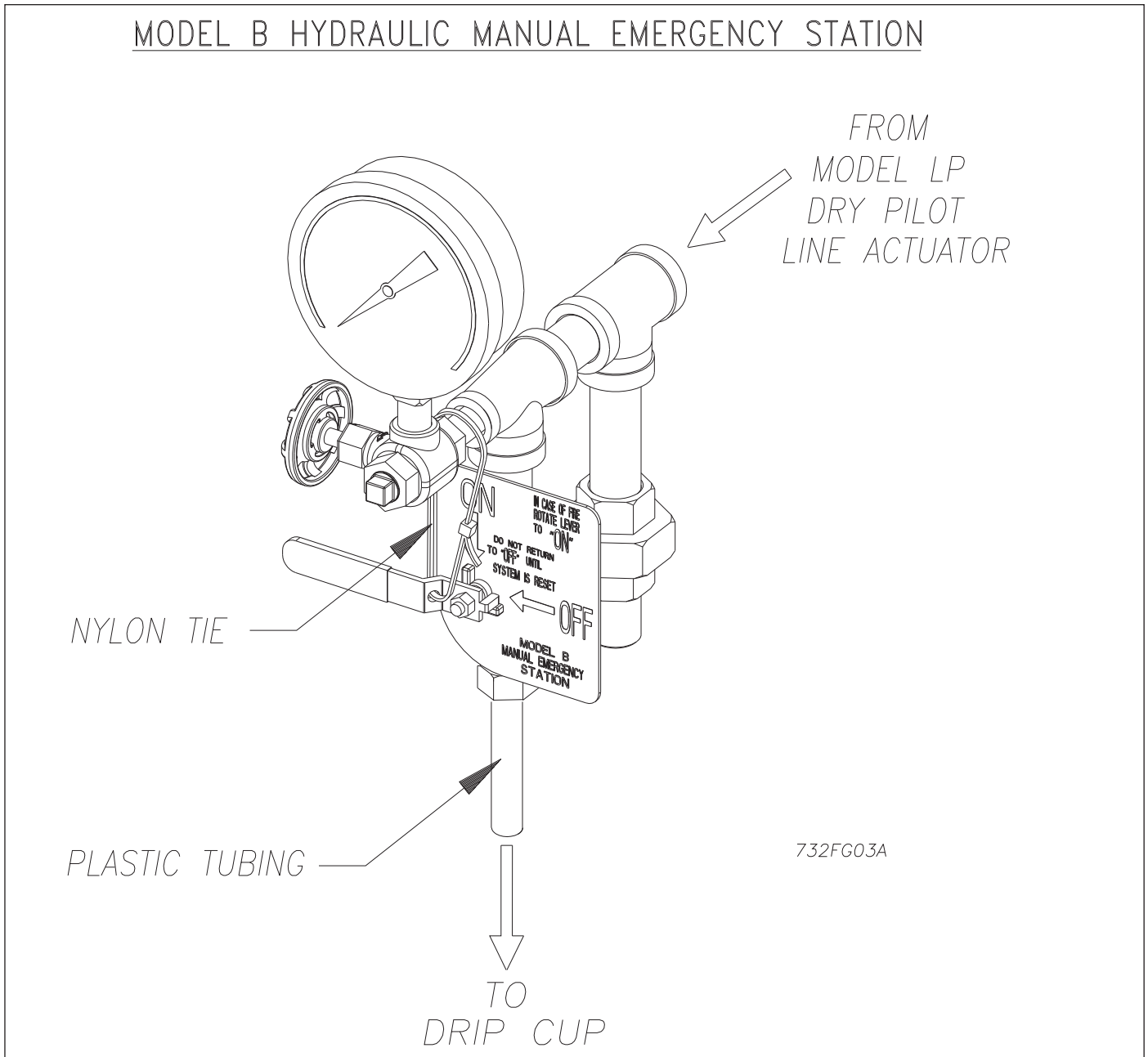

Fig. 3

ber shall be of a piston/push-rod design with diaphragm seal and have a 1/4" vent hole for air/water leakage indication. Trip ratio shall be a 3:1 force differential. Deluge valve shall be of the straight-through design to minimize friction loss, and be capable of being reset without having to remove the valve cover plate through the use of an external reset knob. Inlet restriction orifice shall be factory installed into inlet port of deluge valve push-rod cover plate and not be a separate part of the deluge valve trim. Valve end connections shall be grooved outlets per ANSI/AWWA C606. Deluge valve shall have a rated working pressure of 250 psi (17,2 bar). Deluge valve to be [4" (100 mm)] [6" (150 mm)] [165mm] Reliable Model DDX Deluge Valve (Bulletin 511).

Valve trim shall be Dry Pilot Line Single Interlock Praction consisting of the following components:

- Hydraulic trim shall be galvanized and brass components specifically Listed/Approved with the deluge valve, including an emergency release valve and 2" main drain. Deluge valve's releasing device shall be a low-pressure pneumatic actuator.
- The low-pressure, pneumatic actuator shall be of cast iron construction utilizing a diaphragm and compression spring design to separate the push-rod chamber water pressure from the system piping's pneumatic supervisory pressure. The low-pressure actuator shall only require between 12 and 26 psi (0,8 to 1,8 bar) supervisory pressure for proper setting in accordance with the manufacturer's instructions. Low-pressure pneumatic actuator shall be Reliable Model LP Pilot Line Actuator.
- The low air pressure switch to indicate loss of air pressure in system piping shall be [cULus Listed] and of the bellows-activated type enclosed in a weatherproof, 4x, NEMA 4-rated enclosure incorporating tamper-resistant screws. There shall be two sets of SPDT (form C) contacts rated 10.0 @ 125/250 VAC and 2.5 A @ 6/12/24 VDC. The pressure switch shall have a maximum service pressure rating of 250 psi (17,2 bar). Switch shall be provided with a 1/2" NPT male pressure connection. Low air supervisory switch shall be System Sensor EPS10-2.

Single Interlock Praction System shall be a Reliable Dry Pilot Line Single Interlock Praction System, Bulletin 732.

Pneumatic Supervisory Pressure Supply Options

Owner's Air supply

Supervisory air supply shall be provided by an owner supplied air system in conjunction with a [cULus Listed] automatic pressure maintenance device, capable of maintaining a constant system pressure regardless of pressure fluctuations in the compressed air source. The pressure maintenance device shall consist of galvanized trim and brass parts, including a strainer and a field adjustable air pressure regulator, and have a working pressure rating of 175 psi (12,1 bar). The pressure regulator shall have an adjustable outlet pressure range of 5 to 50 psi (0,34 to 3,4 bar). Pressure maintenance device shall be Reliable Model A-2 (see NFPA13).

Compressed Air Supply

Supervisory air supply shall be provided by an automatic tank-mounted air compressor sized for the capacity (volume) of the single interlock preaction system piping, and be capable of restoring normal air pressure in the system within 30 minutes. Single interlock preaction system shall only require between 12 and 26 psi (0,8 to 1,8 bar) supervisory pressure for proper setting of the low pressure pneumatic actuator in accordance with the manufacturer's instructions. Air supply shall be equipped with an automatic pressure maintenance device capable of maintaining a constant system pressure regardless of pressure fluctuations in the compressed air (or nitrogen) source, or system piping. The pressure maintenance device shall consist of galvanized trim and brass parts, including a strainer and a field adjustable air pressure regulator, and have a working pressure rating of 175 psi (12,1 bar). The pressure regulator shall have an adjustable outlet pressure range of 5 to 50 psi (0,34 to 3,4 bar). Pressure maintenance device shall be Reliable Model A-2.

Nitrogen

Nitrogen cylinders provided by an approved source shall provide the nitrogen supply. Single interlock preaction system shall only require between 10 and 26 psi (0,8 to 1,8 bar) supervisory pressure for proper setting of the low pressure pneumatic actuator in accordance with the manufacturer's instructions. The nitrogen cylinder pressure shall be regulated and supervised through the use of nitrogen regulating device and low-pressure trim kit. This device shall consist of a brass, single stage pressure regulator, equipped with high pressure inlet and low pressure outlet gauges, and 1/4" copper connection tubing with galvanized 3/4" x 1/4" reducer bushing. Optional: Low-pressure trim kit shall be included to monitor the regulated nitrogen supply pressure to provide a low-pressure supervisory alarm. This kit shall include a low-pressure switch with associated galvanized connection trim. Assembly shall be a Reliable Nitrogen Regulating Device. This device is to be used in conjunction with the Reliable Model A-2 Pressure Maintenance Device.

Optional System Accessories

System Control Valve

Praction system control valve shall be a slow close, [cULus Listed] indicating butterfly type valve with a pre-wired supervisory tamper switch assembly. The valve shall be rated for a working pressure of [175 psi (12,1 bar)] [250 psi (17,2 bar)]. System control valve shall be a [4" (100 mm)] [6" (150 mm)] [165mm] Nibco GD-4765-8N Butterfly Valve.

Waterflow Alarm Pressure Switch

Alarm pressure switch shall be provided to indicate water flow and provide a water flow alarm. Pressure switch shall be [cULus Listed] and of the bellows activated type enclosed in a weatherproof, 4x, NEMA 4-rated enclosure incorporating tamper-resistant screws. There shall be two sets of SPDT (Form C) contacts rated at 10.0 A @ 125/250 VAC and 2.5 A @ 6/12/24 VDC. The pressure switch shall have a maximum service pressure rating of 250 psi (17,2 bar) and shall be factory adjusted to operate at a pressure of 4 to 8 psi (0,27 to 0,55 bar) with adjustment up to 20 psi (1,3 bar). Switch shall be provided with a 1/2" NPT male pressure connection. Waterflow alarm pressure switch shall be System Sensor EPS10-2.

Technical Data

Reliable Dry Pilot Line Single Interlock Preaction Systems, with associated trim, sizes 4" (100mm), 6" (150mm) and 165mm are rated for use at minimum water supply pressure of 20 psi (1,4 bar) and maximum supply pressure of 250 psi (17,2 bar). Water supplied to the inlet of the valve and to the pushrod chamber must be maintained between 40°F (4°C) and 140°F (60°C).

The following list of technical bulletins pertains to valves and devices that may be used in this preaction system:

Deluge Valve	Reliable 510/511
Hydraulic Emergency Station (Model A)	Reliable 506
Mechanical Sprinkler Alarm	Reliable 612/613
Pressure Maintenance Device	Reliable 250/251
Fire Alarm Devices	Reliable 700
Waterflow/Low Air Pressure Alarm Switch	System Sensor A05-0176
Nitrogen Regulating Device	Reliable 253
Pilot Line Detector	Reliable 180

Valve Description

- Rated working pressure:
 - Valve & System - 250 psi (17,2 bar)
- Factory tested to a hydrostatic pressure of 500 psi (34,5 bar). (Valve only)
- End and trim connections:
 - ANSI/AWWA C606 grooved inlet and outlet

Groove Dimensions				
Valve Size	Outlet Diameter	Groove Diameter	Groove Width	Outlet Face to Groove
4" (100mm)	4.500" (114mm)	4.334 (110mm)	3/8" (10mm)	5/8" (16mm)
165mm	6.500" (165mm)	6.330" (161mm)		
6" (150mm)	6.625 (168mm)	6.455" (164mm)		

- Threaded openings Per ANSI B 2.1

Valve Size	Color
4" (100mm) 6" (150mm)	Black
165mm	Red

- Face to face dimensions:
 - 4" (100 mm) — 14" (355 mm)
 - 6" (150 mm) & 165 mm — 16" (406 mm)
- Shipping weight:

Valve Size	Weight
4" (100 mm)	64 lb. (29 kg)
6" (150 mm) & 165mm	95 lb. (43 kg)

- Friction loss (Expressed in equivalent length of Schedule 40 pipe, based on Hazen & Williams formula with C=120 and a flow velocity of 15ft/sec (4.6 m/sec)):

Valve Size	Equivalent Length
4" (100mm)	14' (4.27 m)
6" (150mm) & 165mm	29.4' (9 m)

- Installation position: Vertical

Maintenance

Reliable Dry Pilot Line Single Interlock Preaction Systems and associated equipment shall periodically be given a thorough inspection and test. NFPA 25, Inspection, Testing and Maintenance of Water Based Fire Protection Systems, provides minimum maintenance requirements. System components shall be tested, operated, cleaned, and inspected at least annually, and parts replaced as required.

Resetting the Single Interlock Preaction System

Refer to Figs. 2, 4, and 5.

- Close the main valve controlling water supply (Fig. 5) to the Deluge Valve and close off the air supply to the sprinkler system and the dry pilot line.
- Close the pushrod chamber supply valve, valve A (Fig. 5).
- Open the main drain valve, valve B (Fig. 5), and drain system.
- Open all drain valves and vents at low points throughout the system, closing them when flow of water has stopped. Open valve D (Fig. 5).

Note: The above steps accomplish the relieving of pressure in the pushrod chamber of the Deluge Valve.

- With valve F (Fig. 5) open, push in the plunger of ball drip valve, valve E (Fig. 5), to force the ball from its seat, and drain any water in the alarm line.
- With the Model B Manual Emergency Station, valve D (Fig. 5), open, push in and rotate the Deluge Valve's external reset knob (#38, Fig. 4) clockwise until you hear a distinct clicking noise, indicating that the clapper has closed. **Note:** The reset knob can be rotated only after pressure in the pushrod chamber is reduced to atmospheric conditions (0 psig).
- Inspect and replace any portion of the sprinkler system subjected to fire conditions.
- Open valve A (Fig. 5) and allow water to fill the Deluge Valve's pushrod chamber. Close valve D (Fig. 5).
- Bleed any air from the actuation piping. Open valve D (Fig.5) allowing water to flow through the pilot line actuator. Close valve F (Fig. 5). When all air has been expelled from the release line, and there is a solid flow of water into the drain cup H (Fig. 5), apply compressed air or nitrogen through the pressure maintenance device to close the pilot line actuator. **Note:** It may be necessary to temporarily close the main drain (valve B, Fig. 5) in order to build sufficient air pressure to "set up" the Model LP Actuator. Once the Model LP Actuator is "set up", the main drain (valve B, Fig. 5) should be reopened and the remaining procedure followed. Subsequently, close valve D (Fig. 5) and adjust the air or nitrogen pressure to the appropriate value in Table A as indicated on air pressure gauge (#26, Fig. 2).
- Open valve F (Fig. 5). Open slightly the main valve controlling water supply (Fig. 5) to the Model DDX Deluge Valve, closing drain valve B (Fig. 5) when water flows. Observe if water leaks through the ball drip valve, valve G (Fig. 5), into the drip cup H (Fig. 5). If no leak occurs, the Deluge Valve's clapper is sealed. Open slowly, and verify that the main valve controlling water supply is fully opened and properly monitored.

11. Verify that valve A (Fig. 5) and valve F (Fig. 5) are open.
12. Secure the handle of the Model B Manual Emergency Station, valve D (Fig. 5), in the OFF position with a nylon tie (#54, Fig. 2).

Inspection and Testing

Refer to Figs. 2, 4, and 5.

1. **Water supply** — be sure the valve(s) controlling water supply to the Deluge Valve are opened fully and properly monitored.
2. **Alarm line** — be sure that valve F (Fig. 5) is opened and remains in this position.
3. **Other trimming valves** — check that valve A (Fig. 5) is open as well as all of the pressure gauge's 1/4" 3-way valves. Valves D, E and J (Fig. 5) should be closed.
4. **Ball drip valve G (Fig. 5)** — make sure valve F (Fig. 5) is open. Push in on the plunger to be sure the ball check is off its seat. If no water appears, the Deluge Valve's water seat is tight. Inspect the bleed hole (see Fig. 4) on the underside of the push rod chamber for leakage.
5. **System pneumatic pressure** — check that system air pressure corresponds to the values found in Table A. Check the pressure maintenance device for leakage and proper pressure.
6. **Releasing device** — check outlet of the releasing device (i.e., Model LP Dry Pilot Line Actuator or the Model B Manual Emergency Station, valve D (Fig. 5) for leakage. Also verify that tubing drain lines from releasing devices are not pinched or crushed which could prevent proper releasing of the Deluge Valve.
7. **Testing alarms** — make sure valve F (Fig. 5) is open. Open valve J (Fig. 5) permitting water from the supply to flow to the electric sprinkler alarm switch and to the mechanical sprinkler alarm (water motor). After testing, close this valve securely. Push in on the plunger of ball drip valve G (Fig. 5) until all of the water has drained from the alarm line.
8. **Operational test** — Open the Model B Manual Emergency Station, valve D (Fig. 5). **Note:** An operational test will cause the Deluge Valve to open and flow water into the sprinkler system.
9. Secure Model B Manual Emergency Station, valve D (Fig. 5), in the OFF position with a nylon tie (#54, Fig. 2) after the Deluge Valve is reset.

Testing the Model DDX Deluge Valve Without Flowing Water

Refer to Fig. 5

1. Close the main valve controlling water supply to the Deluge Valve.
2. Verify that valve A is open, allowing water to enter the push rod chamber.
3. Close off the air/nitrogen supply to the sprinkler system and the Dry Pilot Line.
4. Decrease pneumatic pressure in the system by opening the 1/4" angle valve, valve E, until the Model LP Dry Pilot Line Actuator operates. This will be indicated by a sudden drop of water pressure on the Deluge Valve's gauges. The operation of the Actuator will vent the push-rod chamber of the Deluge Valve and cause the Valve's clapper to open.
5. To reset the system, close the 1/4" angle valve, valve E, and proceed according to the directions listed in the "Resetting the Single Interlock Preaction System" section of this bulletin.

Draining Excess/Condensate Water From System

Refer to Fig. 6

1. Close the main valve controlling water supply to Deluge Valve. Also close valve A and open main drain valve B.
2. Open condensate drain valve E until all water has drained. Close valve E. **Note:** Be sure not to keep valve E open for an extended period of time because that will cause enough system air to bleed off thereby causing an undesirable activation of a trouble-annunciating device.
3. Close main drain valve B. If system contains pressurized air, allow air pressure to come back up to specification. Open valve A first, and then open the main valve controlling the water supply to the Deluge Valve.

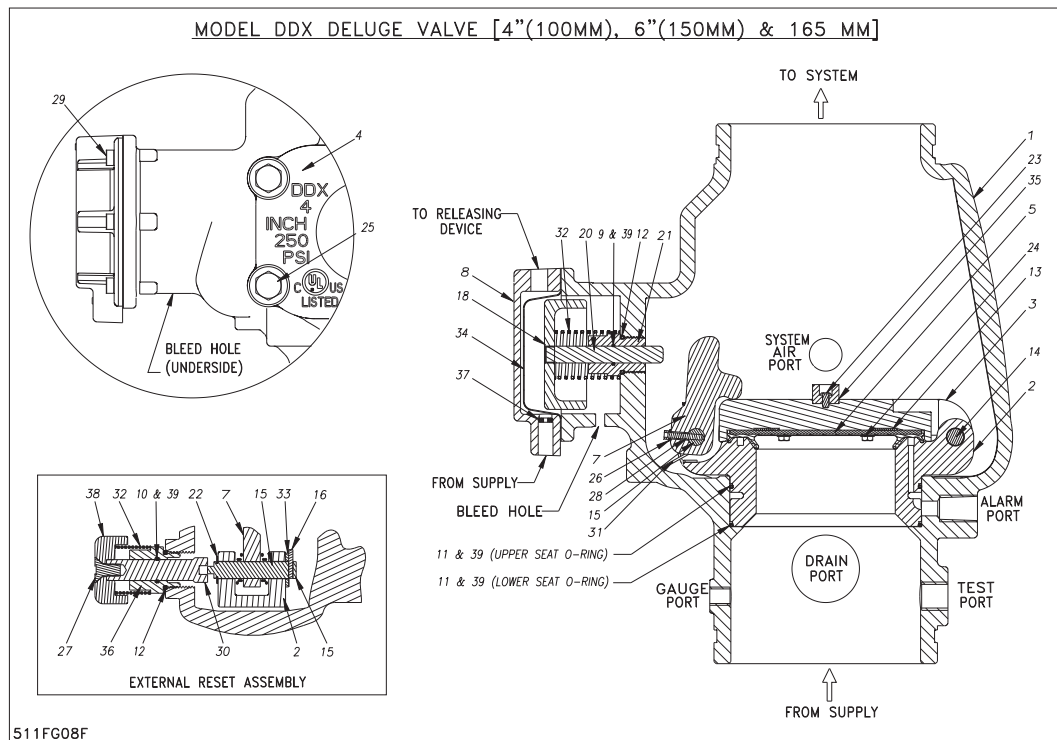

Fig. 4

Models DDX 4" (100mm), 6" (150mm) & 165mm Deluge Valve Parts List

Item No.	Part Number			Description	No. Req'd
	4"(100mm) Valve	6"(150mm) Valve	165mm Valve		
1	91006005	91006007	91006027	Valve Body	1
2	96016004	96016006	96016006	Seat	1
3	91916004	91916006	91916006	Clapper	1
4	92116064	92116066	92116065	Cover	1
5	93416004	93416006	93416006	Seal Faceplate Subassembly	1
6	93706004	93706006	93706006	Gasket, Cover (Not Shown)	1
7	94506004	94506006	94506006	Lever	1
8		92126006		Cover, Pushrod	1
9		95406407		O-ring (014)	1
10		95406007		O-ring (114)	1
11	95406006	N/A		O-ring (156)	2
	N/A	95406016		O-ring (161)	
12		95406024		O-ring (912)	2
13	93706001	N/A	N/A	Gasket, Clapper, 4"	1
	N/A	93706002	93706002	Gasket, Clapper, 6"	
14		96216086		Hinge Pin, Clapper	1
15		96216046		Pin, Lever	1
16		95606131		Threaded Stud, #10-32 x 3/4"	1
17		96216066		Pin, Locking, Seat (Not Shown)	2
18		95106006		Piston	1
19		95200038		Plug, Socket, Ø 3/8" - 18 NPT (Not Shown)	2
20		95506006		Pushrod	1
21		93916006		Pushrod Guide	1
22		95306267		Ring, Retaining (2 Assembled to Item No. 14)	3

Item No.	Part Number			Description	No. Req'd
	4"(100mm) Valve	6"(150mm) Valve	165mm Valve		
23		95606128		Screw, Button Head, #10-32 x 3/8"	1
24		95606129		Screw, Hex Washer Head, #10-32 x 3/8"	4
25	95606107	N/A	N/A	Screw, Hex Cap, Ø 1/2"-13 x 1-1/2"	6
	N/A	91106006	91106006	Screw, Hex Cap, Ø 5/8"-11 x 1-3/4"	
26		96906111		Spring Lock Washer, #10	1
27		95606127		Screw, C'sunk Cap Head, Ø 3/8"-16 x 3/4"	1
28		95606130		Screw, Socket Head, #10-32 x 1"	1
29		95606114		Screw, Socket Head, Ø 1/4"-20 x 5/8"	6
30		93916066		Shaft, Reset	1
31		96406004		Spring, Lever	1
32		96406906		Spring	2
33		96906904		Teflon Washer, Ø 1/2" (2 Assembled to Item No. 14)	3
34		95276006		Diaphragm	1
35		92306006		Disc, Bumper	1
36		94106066		Housing, Reset	1
37		94206406		Inlet, Orifice	1
38		94356006		Knob, Reset	1
39		85000050		O-ring Grease, DuPont™ Krytox® GPL-201	A/R

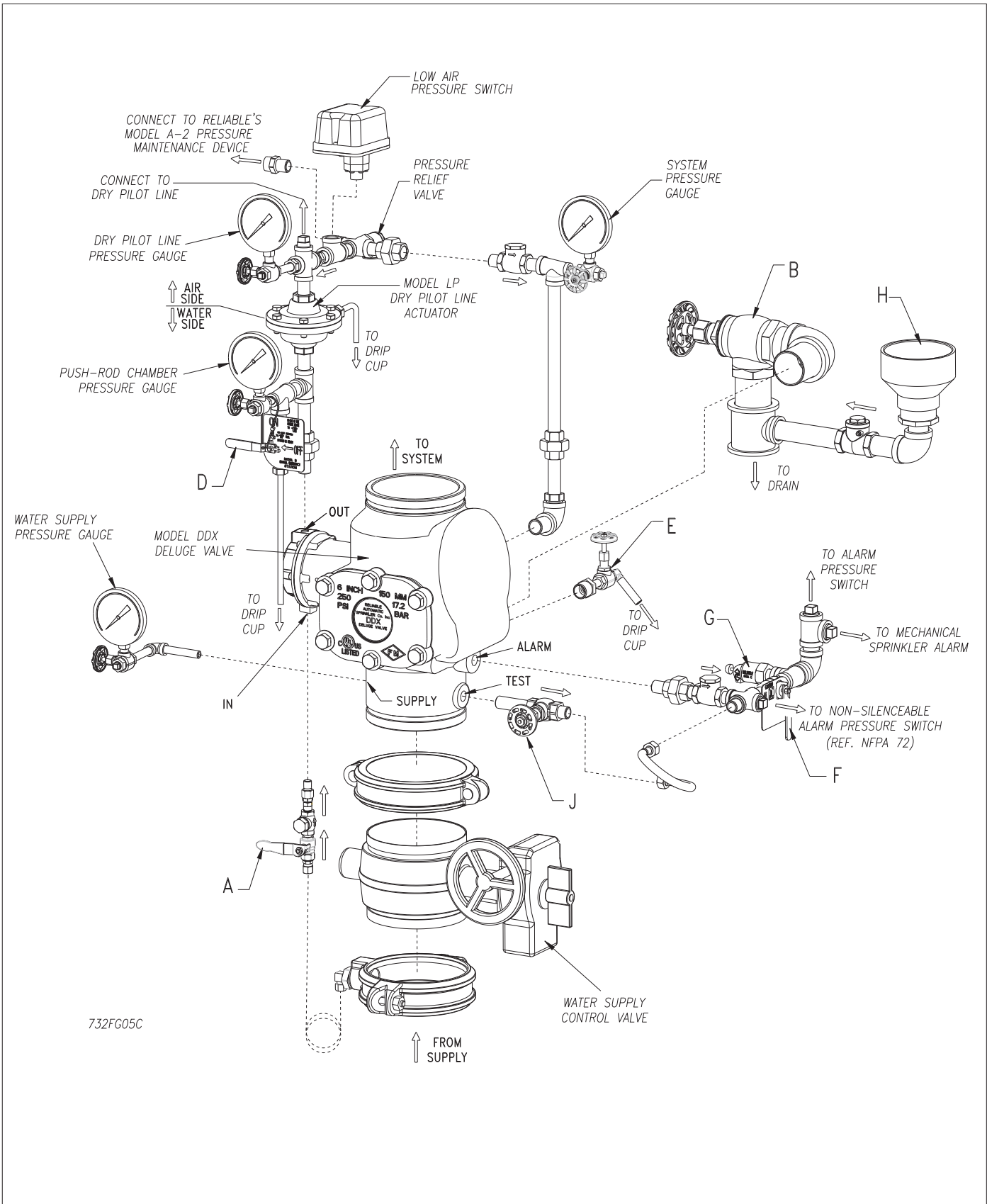

Fig. 5

Maintenance Procedures - Model DDX Deluge Valve

Refer to Figs. 2, 4 & 5.

1. Mechanical sprinkler alarm (water motor—not shown) not operating:

This is most likely caused by a clogged screen in the strainer of the water motor. Proceed as follows: Remove plug from the strainer. Remove and clean the screen. Replace the screen and the plug, and then tighten securely (Ref. Bulletin 613).

2. Leakage out of the ball drip valve E (Fig. 5).

a. Water leakage due to a water column above the Deluge Valve's clapper:

This condition can be caused by leakage past the system side of the Model DDX Deluge Valve's seal faceplate subassembly (#5, Fig. 4). Be sure that this surface is free of any type of debris. To eliminate leakage due to a water column, refer to the section in this bulletin marked "Draining Excess/Condensate Water From System". If the problem continues proceed to the following section.

b. Leakage, air or water from the ball drip valve, G (Fig. 5):

If system air is leaking out the ball drip valve, the problem is either damage to the airside of the Model DDX Deluge Valve's seal faceplate subassembly (#5, Fig. 4), seat (#2, Fig. 4), or the upper seat O-ring (#11, Fig. 4).

If supply water is leaking out the ball drip valve the problem could be caused by damage to the Model DDX Deluge Valve's seal faceplate subassembly (#5, Fig. 4), seat (#2, Fig. 4), or lower seat O-ring (#11, Fig. 4). The following section provides instructions to correct both conditions:

A) Shut down the valve controlling the water supply to the Deluge Valve and open the main drain valve B (Fig. 5). Open the water column drain valve E (Fig. 5). Close the push rod chamber supply valve A (Fig. 5) and open the Model B Manual Emergency Station D (Fig. 5).

B) Remove the Deluge Valve's front (handhold) cover (#4, Fig. 4) and inspect the seat (#2, Fig. 4), clapper (#3, Fig. 4), and seal faceplate subassembly (#5, Fig. 4) for damage.

If inspection indicates damage to the clapper (#3, Fig. 4) or seal faceplate subassembly (#5, Fig. 4) only, then the clapper subassembly can be removed as follows:

At the rear of the valve, disconnect the water column drain trim section starting with the elbow connector (#16, Fig. 2). Then remove the 1/4" globe valve (#28, Fig. 2), followed by the 3/4" x 1/4" reducing bushing (#12, Fig. 2). Remove the retaining ring (handhold cover side) from the clapper hinge pin (#14, Fig. 4) and push this pin through the water column drain line and remove the clapper subassembly. Remove the four retaining screws (#24, Fig. 4) holding the seal faceplate subassembly (#5, Fig. 4). Inspect the clapper (#3, Fig. 4) visually before re-installing. Apply a small amount of silicone-based lubricant to the four retaining screws. Install a new seal faceplate subassembly. Torque the retaining screws to approximately 40 inch-pounds and re-assemble. If the seat (#2, Fig. 4) is damaged or it is suspected that the leakage is through the lower

O-ring (#11, Fig. 4), the seat-clapper subassembly is easily removed as a unit as follows:

Using a 5/16" Allen wrench, remove the two 3/8" NPT pipe plugs (#19 (not shown) Fig. 4) located on the side of the Model DDX Deluge Valve. The seat-clapper subassembly is retained by two locking pins (#17 (not shown) Fig. 4). The centers of these pins have a 1/4"-20 threaded hole. Remove the two locking pins by engaging them with a 1/4"-20 screw or threaded rod and pulling them out (The two locking pins are not threaded, so turning them with the attached 1/4"-20 screw or threaded rod is not recommended. A proven method is to use 1/4"-20 threaded rod with a locknut on the unassembled end. Grab hold of the locknut with pliers or vice-grips and tap the pliers or vice-grips in the direction away from the Deluge Valve. Doing so should pull the locking pins out of the Deluge Valve.). With the clapper (#2, Fig. 4) in the closed position (not latched), dislodge the seat-clapper subassembly from the Valve's body by inserting two slotted screwdrivers under the lever and clapper mounting ears and pry up until the seat-clapper subassembly is free of its bore. Reach into the valve and grasp the seat-clapper subassembly from the sides. Lift up and rotate the seat-clapper subassembly through 90 degrees about the centerline axis of the Model DDX Deluge Valve so that the lever side of the seat-clapper subassembly faces the outlet of the Deluge Valve. Rotate the seat-clapper subassembly around the centerline of the Deluge Valve until the top of the clapper faces the handhold opening and then pull it out clapper hinge-pin side first. Visually examine all components of the seat-clapper subassembly replacing any component that appears damaged. New O-rings (#11, Fig. 4) should always be used for reassembly.

Reassembly:

It is likely that the lower seat O-ring (#11, Fig. 4) has remained at the bottom of the Deluge Valve body's bore. Discard this O-ring and clean the bore. Lubricate the bore with O-ring grease and place the lower seat O-ring on the step at the bottom of the bore, verifying that it is in full contact with the bore. Lubricate the bottom step and upper seat O-ring (#11, Fig. 4) of the refurbished seat-clapper subassembly. Insert the seat-clapper subassembly into the handhold opening of the Deluge Valve lever-first, rotating it until the lever side faces the outlet of the Deluge Valve. Rotate the seat-clapper subassembly until the lever (#7, Fig. 4) faces the push rod (#20, Fig. 4), then drop the seat-clapper subassembly into the Deluge Valve's bore. Verify that the seat-clapper subassembly is in the fully down position and check to see that the lever lines up with the push rod. Adjust if necessary. Clean and lubricate the two locking pins (#17 (not shown) Fig. 4) with O-ring lubricant and drive them into the Deluge Valve body. Then reinstall the 3/8" NPT pipe plugs (#19 (not shown) Fig. 4). Reassemble the handhold cover and set up the Model DDX Deluge Valve as per the section "Resetting the Single Interlock Preaction System."

3. Leakage out of the push rod chamber vent hole:

A small bleed hole is located on the underside of the push rod chamber (see Fig. 4). If there is air or water leakage coming out of this hole, do the following:

a) Shut down the valve controlling water supply to the Deluge Valve. Relieve the inlet pressure by opening the main drain valve B (Fig. 5). Close the valve A (Fig. 5) that supplies water to the push rod chamber, and open the Model B Manual Emergency Station, valve D (Fig.4).

b) Remove the trim at the unions nearest to the push rod chamber cover (#8, Fig. 4).

c) Take the push rod chamber cover (#8, Fig. 4) off by removing the six retaining screws (#29, Fig. 4).

CONDITION ONE (Water coming out of the bleed hole):

Water coming out of the bleed hole is caused by a leaking diaphragm (#34, Fig. 4). Visually inspect the push rod chamber cover (#8, Fig. 4) and piston (#18, Fig. 4) to determine what could have damaged the diaphragm and correct. Install a new diaphragm. **NOTE:** The diaphragm has two different surfaces, it is not bi-directional. It will fail if installed backwards! Roll the diaphragm so that the smooth surface (the pressure side) conforms to the inside of the push rod chamber cover and reassemble the six retaining screws (#29, Fig. 4) with an installation torque of 15 foot-pounds. Set up the Model DDX Deluge Valve as per the section "Resetting the Single Interlock Preaction System."

CONDITION TWO (System Air coming out of the bleed hole):

System air coming out of the bleed hole is caused by a defective O-ring assembled to the push rod guide (#21, Fig. 4). Remove the piston-push rod subassembly, push rod spring (#32, Fig.4), and push rod guide (#21, Fig. 4). Verify by hand turning, that the push rod cannot be unscrewed from the piston. Replace all O-rings and the push rod guide. The correct installation torque for the push rod guide is 35 inch-pounds. **CAUTION:** Do not over-tighten the push rod guide. Reassemble the components that were initially removed. Re-install the diaphragm (#34, Fig. 4) if it appears to be in good shape, otherwise, replace it also. **NOTE:** The diaphragm has two different surfaces, it is not bi-directional. It will fail if installed backwards! Roll the diaphragm so that the smooth surface (the pressure side) conforms to the inside of the push rod chamber cover and reassemble the six retaining screws (#29, Fig. 4) with an installation torque of 15 foot-pounds. Set up the Model DDX Deluge Valve as per the section "Resetting the Single Interlock Preaction System."

MODEL LP DRY PILOT LINE ACTUATOR

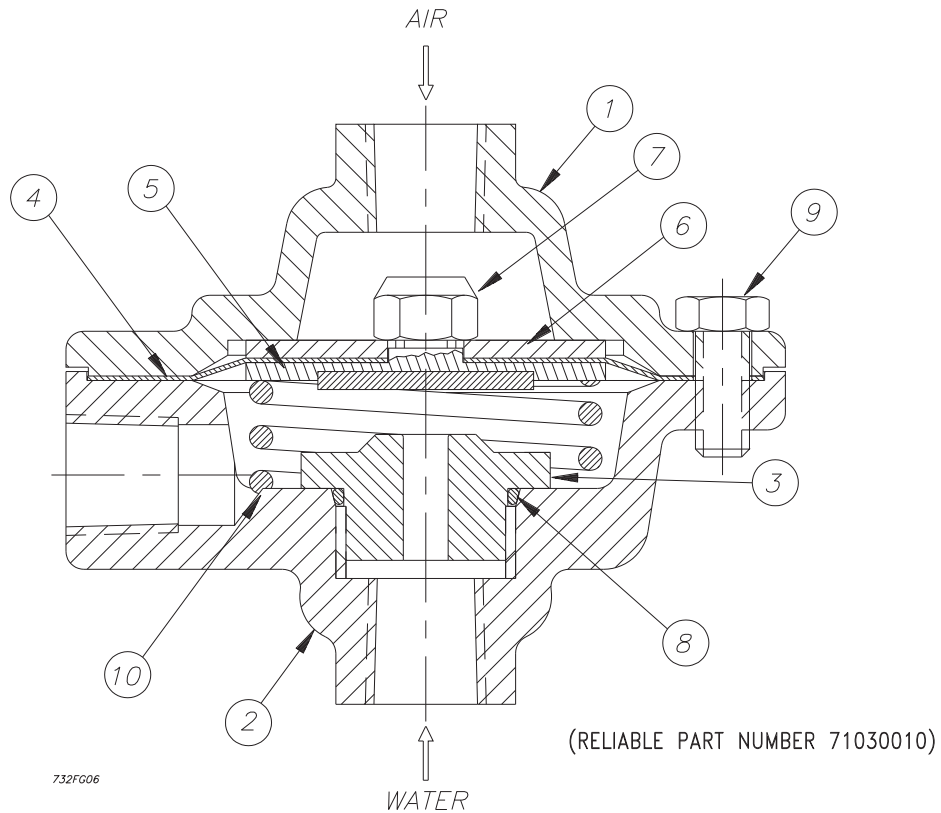

Fig. 6

Model LP Dry Pilot Line Actuator Parts List P/N 71030010

Item No.	Part No.	Description	Qty. Required
1	94106936	Lower Housing	1
2	94106935	Upper Housing	1
3	96006905	Seat	1
4	92206311	Diaphragm	1
5	95106911	Facing Plate Assembly	1
6	96906311	Diaphragm Washer	1
7	94906406	Facing Plate Nut	1
8	95406901	Seat O-Ring	1
9	95606305	Bolt	6
10	96406902	Compression Spring	1

Maintenance Model LP Dry Pilot Line Actuator

Refer to Figs. 5 and 6

If water constantly flows through the Model LP Dry Pilot Line Actuator and into the drain, there is a leak in the seal of the Actuator's seat.

1. Close the main valve controlling water supply (Fig. 5) to the Deluge Valve and close off the air/nitrogen supply to the sprinkler system and the Dry Pilot Line. Close valve A (Fig. 5).
2. Drop pressure in the system by opening the 1/4" angle valve, valve E (Fig. 5), and remove the Actuator from the system.
3. Remove all six bolts (#9, Fig. 6) holding the Actuator together. Clean or replace the facing plate assembly (#5, Fig. 6) and seat (#3, Fig. 6).
4. Reassemble the Actuator, using a torque of 8 ft-lbs on the facing plate nut (#7, Fig. 6) and 12 ft-lbs on the six bolts (#9, Fig. 6). Use a cross-tightening pattern. Reinstall the Actuator. Set up the Model DDX Deluge Valve as per the section "Resetting the Single Interlock Preaction System."

Ordering Information

Specify

- **Valve Model & Size** — 4" (100mm) Model DDX Deluge Valve (P/N 6103040026), 6" (150mm) Model DDX Deluge Valve (P/N 6103060024), 165mm Model DDX Deluge Valve (P/N 6103060028).
- **Trim** — The trim set is available in individual parts, in time-saving segmentally assembled kit forms, or fully assembled to the Model DDX Deluge Valve with or without a control valve.
- **Low Air Pressure Switch** —UL/FM Approved (System Sensor Model EPS40-2) or ULC Listed (System Sensor Model EPSA40-2).

	Trim Configurations	Trim Part Numbers		
		4" (100mm) Valve	6" (150mm) Valve	165mm Valve
UL/FM Approved Pressure Switch	Fully Assembled to DDX Valve w/Control Valve	6505040281	6505060281	Not Available
	Fully Assembled to DDX Valve w/o Control Valve	6505040280	6505060280	6505065277
	Segmentally Assembled (DDX Valve Sold Separately)	6503001713		
	Individual Parts (DDX Valve Sold Separately)	6503001712		
ULC Listed Pressure Switch	Fully Assembled to DDX Valve w/Control Valve	6505040283	6505060283	Not Available
	Fully Assembled to DDX Valve w/o Control Valve	6505040282	6505060282	6505065280
	Segmentally Assembled (DDX Valve Sold Separately)	6503001715		
	Individual Parts (DDX Valve Sold Separately)	6503001714		

Note: For metric installations, a 2" NPT x R2, ISO 7/1 x Close Nipple (Reliable P/N 98543401) is sold Separately as an adapter for the single drain outlet of the trims.

• Additional Equipment (Refer to Fig.7)

Item No.	Component Part	Mfgr.	Description	Technical Bulletin
1	Water Supply Control Valve	Select	OS&Y, 4"(100mm), 6" (150mm) or 165mm	-
			Butterfly, 4"(100mm), 6" (150mm) or 165mm	-
	Tamper Switch (Optional) for OS&Y Valve (Optional) for Butterfly Valve	B	Model OS&Y2	System Sensor A05-0196
			Model P1BV2	System Sensor A05-0197
2	Deluge Valve	A	Model DDX, 4"(100mm), 6" (150mm) or 165mm	Reliable 510 / 511
3	Single Interlock Trim Kit	A	Refer to Parts List in this Bulletin	Reliable 732
4	Waterflow Alarm Pressure Switch	B	Model EPS10-2 (DPDT, UL, FM)	System Sensor A05-0176
			Model EPSA10-2 (DPDT, ULC)	
5	Low Air Alarm Pressure Switch	B	Model EPS40-2 (DPDT, UL, FM)	System Sensor A05-0177
			Model EPSA40-2 (DPDT, ULC)	
6	Mechanical Alarm (Optional)	A	Model C	Reliable 612 / 613
7	Manual Emergency Station	A	Model A Hydraulic (Pilot Line) Type	Reliable 506
8	Pilot Line Detector / Sprinkler	A	Model F1-FTR	Reliable 180
9	Sprinklers	A	Closed Type	Reliable 110, 117, 131, 136, etc.
10	Pressure Maintenance Device	A	Model A-2	Reliable 250 / 251
11	Nitrogen Regulating Device	A	Regulator with Optional Low Air Pressure Switch	Reliable 253
12	Air Compressor	C	Tank Mounted	Gast H-10-0801

System Equipment Manufacturers

- (A) The Reliable Automatic Sprinkler Co., Inc.
 (B) System Sensor
 (C) Gast Manufacturing Corp.

DRY PILOT LINE SINGLE INTERLOCK PREACTION SYSTEM COMPONENTS

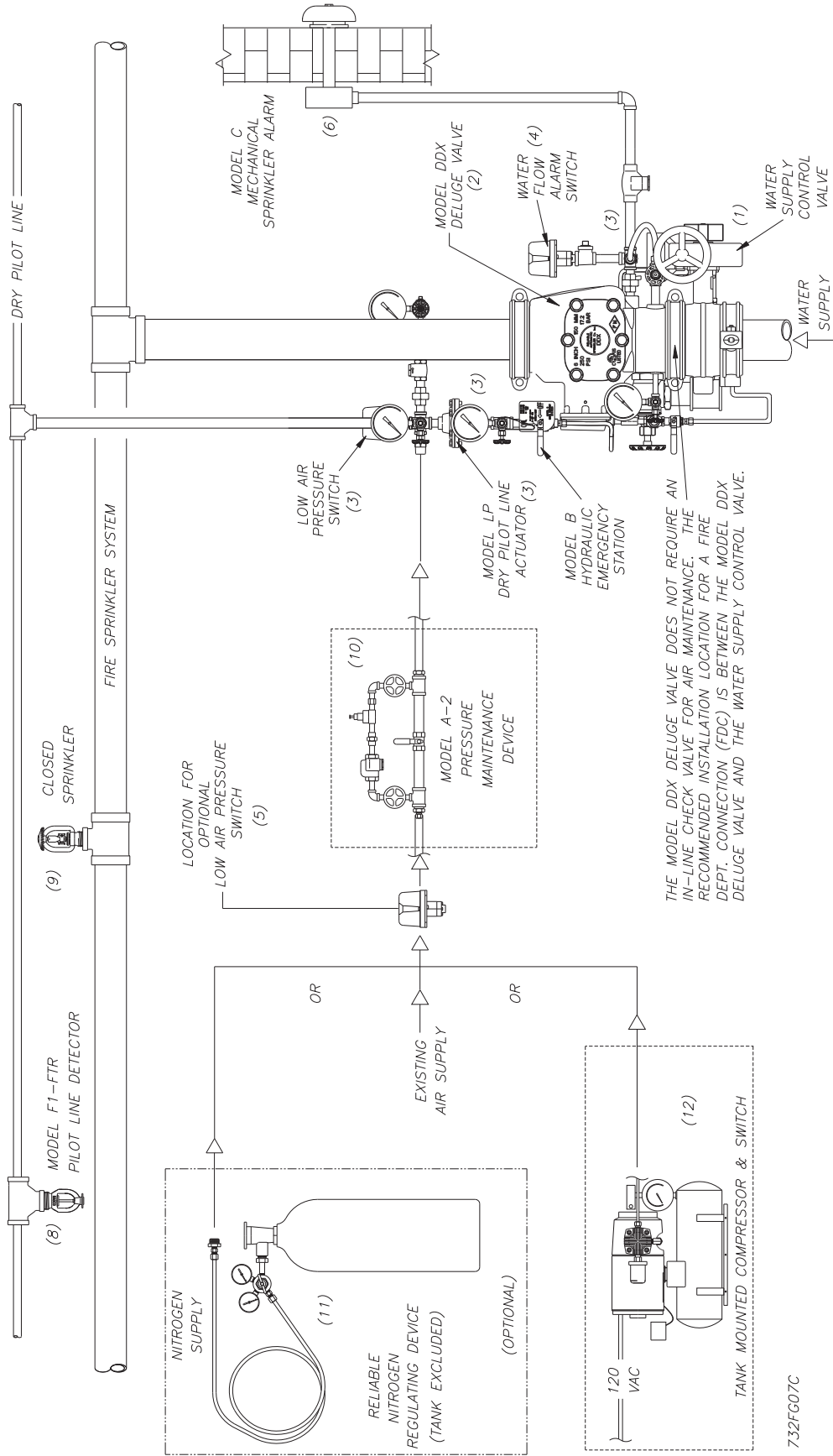

732FG07C

Fig. 7

Installation Dimensions in Inches (mm)															
VALVE	A	B	C	*D	E	F	G	H	J	K	L	M	N	P	Q
4" (100mm)	5 ¹ / ₄ (133)	6 ³ / ₄ (171)	9 ¹ / ₂ (241)	14 (355)	29 (737)	22 ³ / ₄ (578)	6 ¹ / ₂ (165)	8 ¹ / ₂ (216)	10 (254)	5 ¹ / ₂ (140)	8 ¹ / ₂ (216)	13 ¹ / ₂ (343)	2 ¹ / ₂ (64)	6 ¹ / ₄ (159)	12 (305)
6" (150mm) & 165mm	6 ¹ / ₄ (159)	7 ³ / ₄ (197)	10 ¹ / ₂ (267)	16 (406)	30 (767)	23 ³ / ₄ (603)	7 ¹ / ₂ (191)	8 ¹ / ₂ (216)	10 (254)	5 ¹ / ₂ (140)	8 ¹ / ₂ (216)	13 ¹ / ₂ (343)	3 ¹ / ₄ (83)	8 ³ / ₄ (222)	12 ¹ / ₂ (318)

*** Total take out dimension for Fully Assembled to DDX Valve w/Control Valve Configurations:**

4" - 20⁷/₁₆, 6" - 23³/₄, 165 mm - N/A

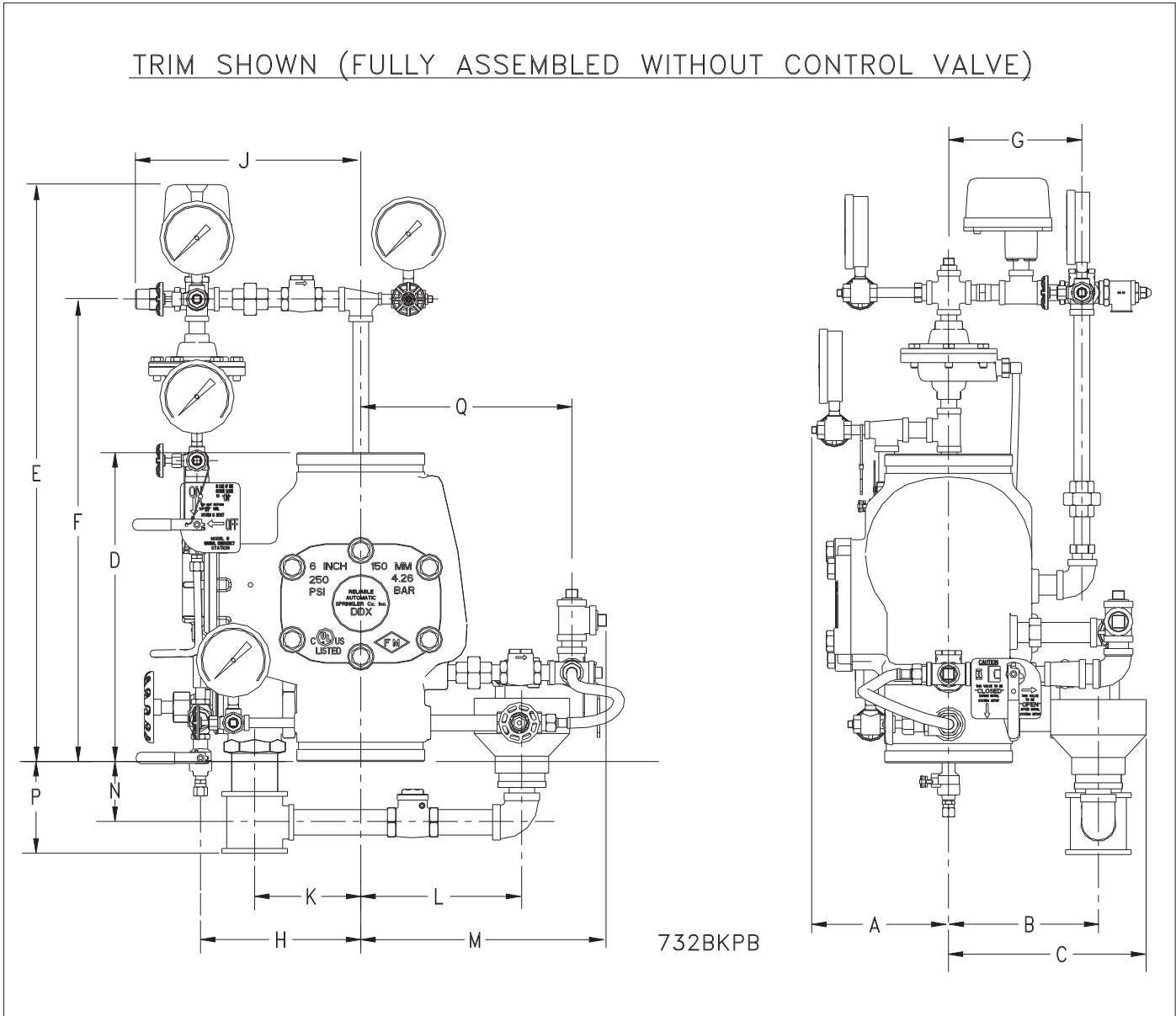

The equipment presented in this bulletin is to be installed in accordance with the latest pertinent Standards of the National Fire Protection Association, Factory Mutual Research Corporation, or other similar organizations and also with the provisions of governmental codes or ordinances whenever applicable.

Products manufactured and distributed by Reliable have been protecting life and property for over 90 years, and are installed and serviced by the most highly qualified and reputable sprinkler contractors located throughout the United States, Canada and foreign countries.

Manufactured by



The Reliable Automatic Sprinkler Co., Inc.

(800)431-1588
 (800)848-6051
 (914)829-2042
www.reliablesprinkler.com

Sales Offices
 Sales Fax
 Corporate Offices
 Internet Address



Revision lines indicate updated or new data.

EG. Printed in U.S.A. 09/11 P/N 9999970304