

Reliable®

Double Interlock Preaction System 4" (100mm), 6" (150mm) & 165mm Sizes

Instructions for Installation, Operation, Care and Maintenance

10 - 26 PSI (0,7 - 1,8 bar) Pneumatic Supervising
Pressure With Electric / Pneumatic Actuation
Type F System

- Available with 175 psi (12,1 bar) or 250 psi (17,2 bar) Rated Solenoid Valve
- Externally Resettable Clapper
- One Main Drain

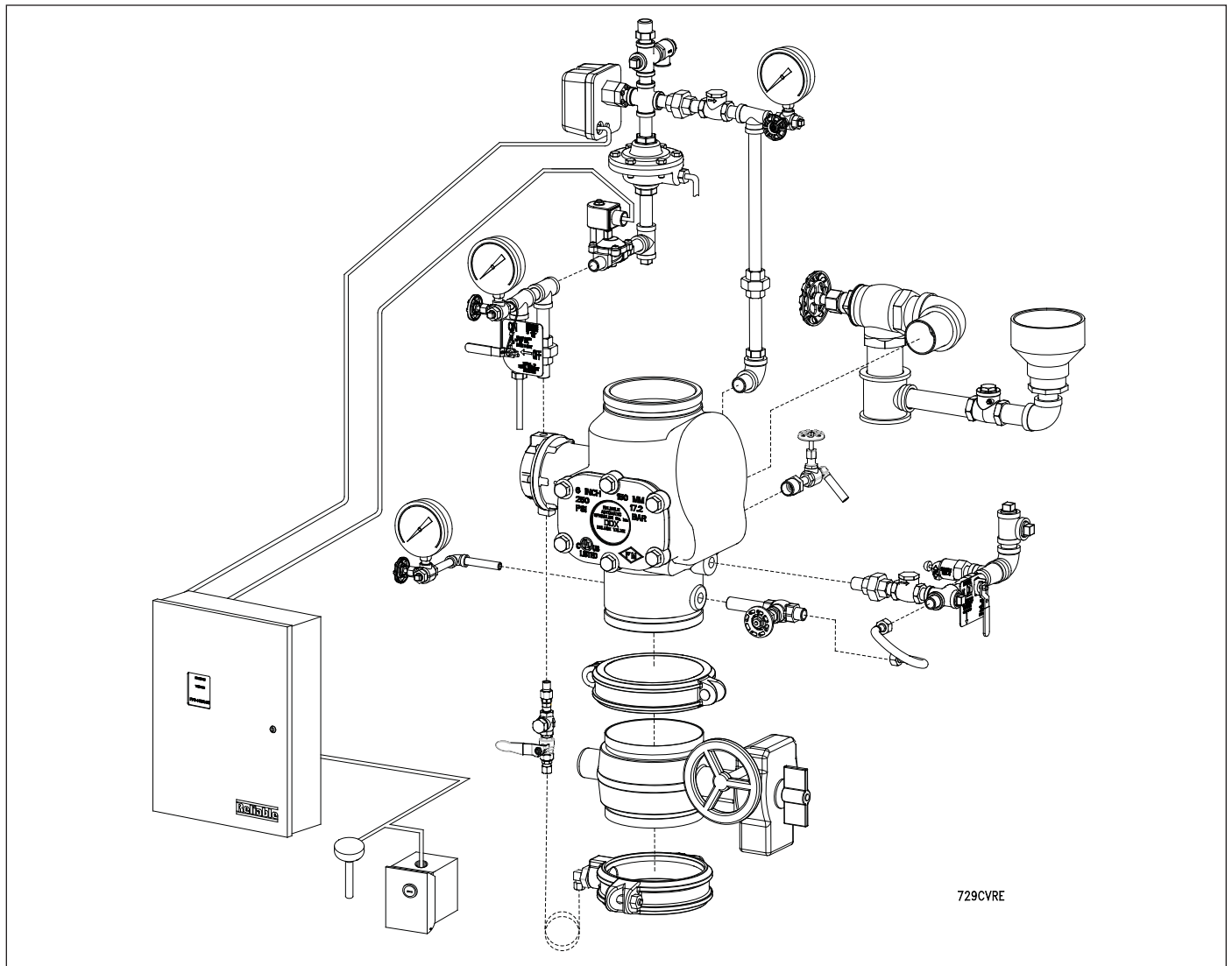

General Description

Type F Double Interlock Preaction Systems are designed for water-sensitive areas that require the maximum protection from inadvertent water flow into the sprinkler system piping. A refrigerated area is an example of this type of water sensitive environment.

The double interlock trim package includes a normally-closed solenoid valve (175 psi (12,1 bar) or 250 psi (17,2 bar) rated) and the Model LP Dry Valve Actuator arranged in series as releasing devices. The sprinkler system is pressurized with air or nitrogen that keeps the Model LP Dry Valve Actuator closed. To flow water into a Type F Double Interlock Preaction System, two events must take place. The Model LP Dry Valve Actuator must be opened by a venting of the sprinkler system's air pressure, and the normally – closed solenoid valve must be energized open by properly activating the releasing/control panel, i.e. when a fire detection device or manual emergency station is operated.

In the event that the system piping is ruptured, or a sprinkler head is accidentally opened, the Model LP Dry Valve Actuator will open and a low system air pressure alarm will sound. The Model DDX Deluge Valve, however, will not be released to flow water since the solenoid valve still remains closed. The same end result would occur if a fire detection device were falsely operated. The control panel will activate an alarm, however again, the Model DDX Deluge Valve will not flow water due to the fact that the Model LP Dry Valve Actuator remains closed.

This requirement for both a detector and a sprinkler to operate before the Model DDX Deluge Valve releases water into the preaction system assures maximum protection against inadvertent water flow before a sprinkler is open. Double interlock preaction systems are primarily used to protect refrigerated areas where accidental water release before a sprinkler is opened can cause ice blockage, resulting in an inoperative sprinkler system and substantial property damage.

At the heart of Reliable's Type F Double Interlock Preaction System is the Model DDX Deluge Valve. This Deluge Valve is a hydraulically operated, straight- through-design, differential-

type valve (see Fig. 1). System maintenance is simplified since priming water is not required and the Deluge Valve can be re-set externally without cover removal. This is accomplished by pushing in and turning the external reset knob at the rear of the Deluge Valve (see Fig. 1). This feature provides a significant system-restoration time advantage

The Reliable Type F Double Interlock Preaction System trim set (see Fig. 2) provides all of the necessary equipment for connections to the Model DDX Deluge Valve's pushrod chamber inlet and outlet ports, the 2" (50mm) main drain, alarm devices, air supply, water supply, and required pressure gauges. This trim set is available in individual parts, in time-saving, segmentally assembled kit forms, or fully assembled to the Model DDX Deluge Valve (with or without a control valve).

All sizes Type F Double Interlock Preaction System trim sets may be equipped with the optional Reliable Model B1 Accelerator, trim kit P/N 651600003, (see Figs. 2 & 3). This device acts as an exhaustor which will hasten operation of the Model LP Dry Valve Actuator and minimize the water delivery time for the entire system.

Listings & Approvals

Reliable Type F 4" (100mm), 6" (150mm) and 165mm Double Interlock Preaction Systems are Factory Mutual Approved Refrigerated Area Sprinkler Systems for use in refrigerated rooms or buildings. Refrigerated area sprinkler systems are FM Approved as complete systems. Systems are FM approved for use with thermal detectors and Class A detector wiring only.

Reliable Type F 4" (100mm), 6" (150mm) and 165mm Double Interlock Preaction Systems are Listed by Underwriters Laboratories, Inc. and UL certified for Canada (cULus) as Special System Water Control Valves – Double Interlock Type (VLJH) category.

The NYC acceptance number for this system is MEA 258-93-E.

The Reliable Type F Double Interlock Preaction System is UL Listed and FM Approved only when used with the trim components shown in Fig. 2.

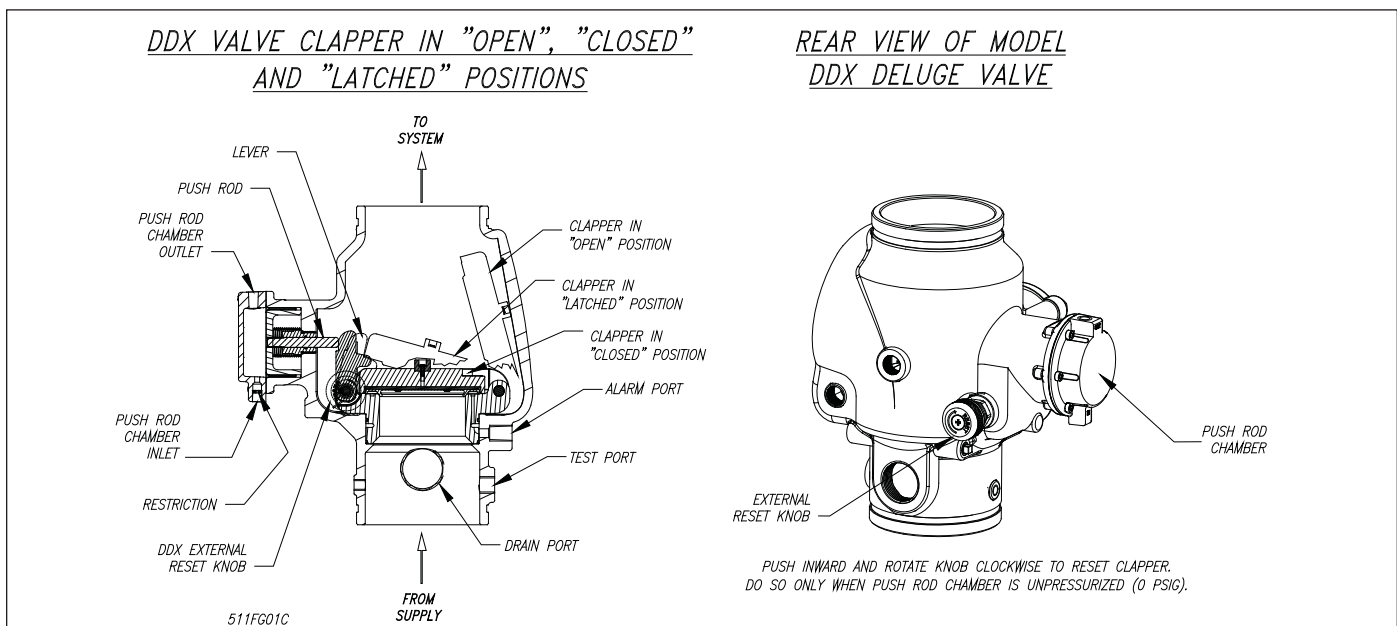
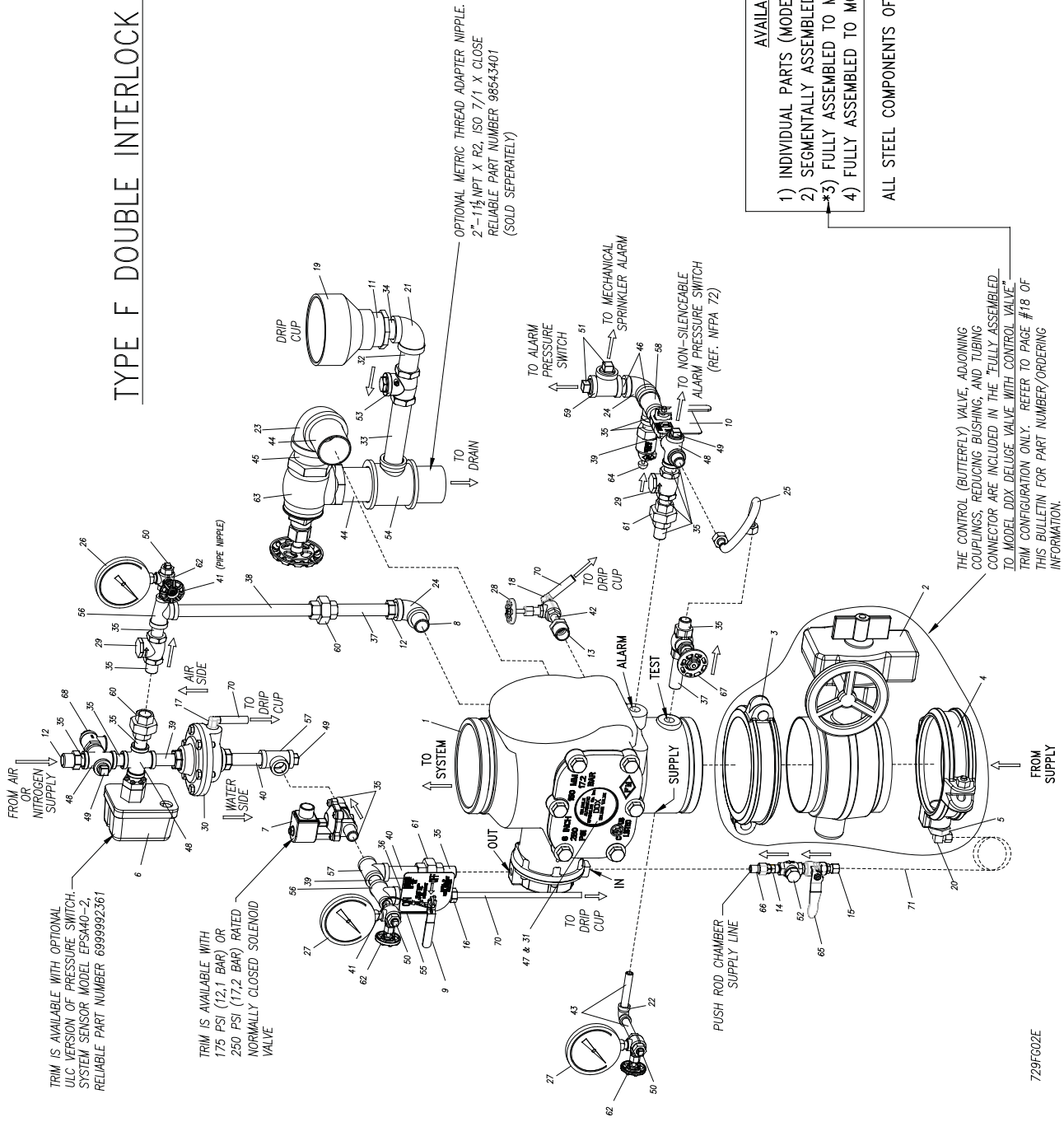

Fig. 1

TYPE F DOUBLE INTERLOCK PREACTION TRIM



- AVAILABLE TRIM CONFIGURATIONS:**
- 1) INDIVIDUAL PARTS (MODEL DDX DELUGE VALVE SOLD SEPARATELY)
 - 2) SEGMENTALLY ASSEMBLED (MODEL DDX DELUGE VALVE SOLD SEPARATELY)
 - *3) FULLY ASSEMBLED TO MODEL DDX DELUGE VALVE WITH CONTROL VALVE
 - 4) FULLY ASSEMBLED TO MODEL DDX DELUGE VALVE WITHOUT CONTROL VALVE

ALL STEEL COMPONENTS OF THE TRIM ASSEMBLIES ARE GALVANIZED

THE CONTROL (BUTTERFLY) VALVE, ADJOINING COUPLINGS, REDUCING BUSHING, AND TUBING CONNECTOR ARE INCLUDED IN THE "FULLY ASSEMBLED TO MODEL DDX DELUGE VALVE WITH CONTROL VALVE" TRIM CONFIGURATION ONLY. REFER TO PAGE #18 OF THIS BULLETIN FOR PART NUMBER/ORDERING INFORMATION.

729FG02E

Fig. 2

**Type F Double Interlock Preaction Trim Parts List
(Refer to Fig. 2)**

Item No	Part No.	Description	Qty.
1	6103060024	Assembly, Valve, 6" (150mm) For 6" Ass'y Only	1
	6103040026	Assembly, Valve, 4" (100mm) For 4" Ass'y Only	
2	6215052400	Waffer-Butterfly Valve, 6" For 6" Ass'y Only	1
	6215051600	Waffer-Butterfly Valve, 4" For 4" Ass'y Only	
3	7g05242400	Coupling, Rigid, 6" For 6" Ass'y Only	1
	7505161600	Coupling, Rigid, 4" For 4" Ass'y Only	
4	7d05464200	Coupling, Rigid, 6" W/1" Outlet For 6" Ass'y Only	1
	7d05444200	Coupling, Rigid, 4" W/3/4" Outlet For 4" Ass'y Only	
5	98048028	Bushing, Reducer, 1" X 1/4", Galv. For 6" Ass'y Only	1
	98048025	Bushing, Reducer, 3/4" X 1/4", Galv. For 4" Ass'y Only	
6	6999991340	Switch, Pressure (Eps40-2) (UL/FM)	1
	6999992361	Switch, Pressure (Epsa40-2) (ULC)	
7	6871020000	Valve, Solenoid (175 Psi) 175 Psi Rated	1
	6871020020	Valve, Solenoid (250 Psi) 250 Psi Rated	
8	98543215	Nipple, Steel, Galv., 3/4" X 1-1/2" For 6" Ass'y Only	1
	98543232	Nipple, Steel, Galv., 3/4" X 2" For 4" Ass'y Only	
9	78653000	Assembly, Manual Emergency Station	1
10	78653004	Assembly, Valve Caution Station, 1/2"	1
11	98048015	Bushing, Reducer, 2" Spigot X 1" Nptf, Pvc	1
12	98048022	Bushing, Reducer, 3/4" X 1/2", Galv.	2
13	98048025	Bushing, Reducer, 3/4" X 1/4", Galv.	1
14	98840147	Check Valve, 1/4" Npt, Poppet Type Inline	1
15	92056702	Connector, 3/8" Tubing X 1/4" Npt	1
16	92056810	Connector, 3/8" ID Tube X 1/2" Npt	1
17	92056704	Connector, Elbow, 3/8" ID Tube X 1/2" Npt	1
18	92056705	Connector, Elbow, 3/8" ID Tube X 1/4" Npt	1
19	98050004	Drain Cup, Pvc	1
20	92056703	Elbow, Male, 3/8" Tube X 1/4 Npt	1
21	98174403	Ell, 1", Mall Iron, Galv.	1
22	98174404	Ell, 1/4", Mall Iron, Galv.	1
23	98174405	Ell, 2", Mall Iron, Galv.	1
24	98174402	Ell, 3/4", Mall Iron, Galv.	2
25	96920912	Flex Line, 12"	1
26	98248000	Gauge, Air Pressure (0-80 Psi)	1
27	98248001	Gauge, Water Pressure (0-300 Psi)	2
28	98840172	Globe Valve, 1/4"	1

Item No	Part No.	Description	Qty.
29	98840181	Horiz. Swing Check Valve, 1/2" Npt	2
30	71030010	Model Lp Pilot Line Actuator	1
31	94616919	Nameplate, Double Interlock, Type F	1
32	98543222	Nipple, Steel, Galv., 1" X 3-1/2"	1
33	98543266	Nipple, Steel, Galv., 1" X 6"	1
34	98543213	Nipple, Steel, Galv., 1" X Close	1
35	98543223	Nipple, Steel, Galv., 1/2" X 1-1/2"	15
36	98543210	Nipple, Steel, Galv., 1/2" X 2-1/2"	1
37	98543228	Nipple, Steel, Galv., 1/2" X 4-1/2"	2
38	98543252	Nipple, Steel, Galv., 1/2" X 10-1/2"	1
39	98543209	Nipple, Steel, Galv., 1/2" X 2"	3
40	98543230	Nipple, Steel, Galv., 1/2" X 3"	2
41	98543226	Nipple, Steel, Galv., 1/4" X 1-1/2"	2
42	98543244	Nipple, Steel, Galv., 1/4" X 2"	1
43	98543220	Nipple, Steel, Galv., 1/4" X 3"	2
44	98543208	Nipple, Steel, Galv., 2" X 3"	2
45	98543238	Nipple, Steel, Galv., 2" X Close	1
46	98543279	Nipple, Steel, Galv., 3/4" X Close	2
47	99080002	Pad-Adhesive	1
48	98750003	Pipe Cross, 1/2", Galv.	3
49	98604406	Plug, Iron, Sq. Hd., 1/2"	3
50	98614403	Plug, Iron, Sq. Hd., 1/4"	3
51	98614401	Plug, Iron, Sq. Hd., 3/4"	2
52	98727607	Strainer, 1/4"	1
53	98840145	Swing Check Valve, 1" Npt	1
54	96606627	Tee, Glvn, 2" X 2" X 1"	1
55	89141112	Tie, Retaining	9
56	98761649	Tee, Glvn., 1/2" X 1/4" X 1/2"	2
57	98761651	Tee, Glvn., 1/2"	2
58	96606612	Tee, Glvn., 3/4" X 1/2" X 1/2"	1
59	96606601	Tee, Glvn., 3/4"	1
60	98815204	Union, "O" Ring Seal, Galv., 1/2"	2
61	98815200	Union, 1/2", Iron, Galv.	2
62	98840160	Valve, 3-Way, 1/4"	3
63	98840100	Valve, Angle, 2"	1
64	78653100	Valve, Ball Drip, 1/2"	1
65	98840117	Valve, Ball, 1/4" Nptf X 1/4" Nptm	1
66	98840187	Valve, Check, 1/4" Nptf X 1/4" Nptm	1
67	98840171	Valve, Globe, 1/2"	1
68	98840195	Valve, Relief, 1/2", 33 Psi	1
69	----	----	--
70	96686756	Tubing, Pvc, 3/8" ID X 6 Ft.	1
71	98768008	Copper Tubing, 3/8"	30"

RELIABLE MODEL B1 ACCELERATOR KIT (P/N 6516000003)

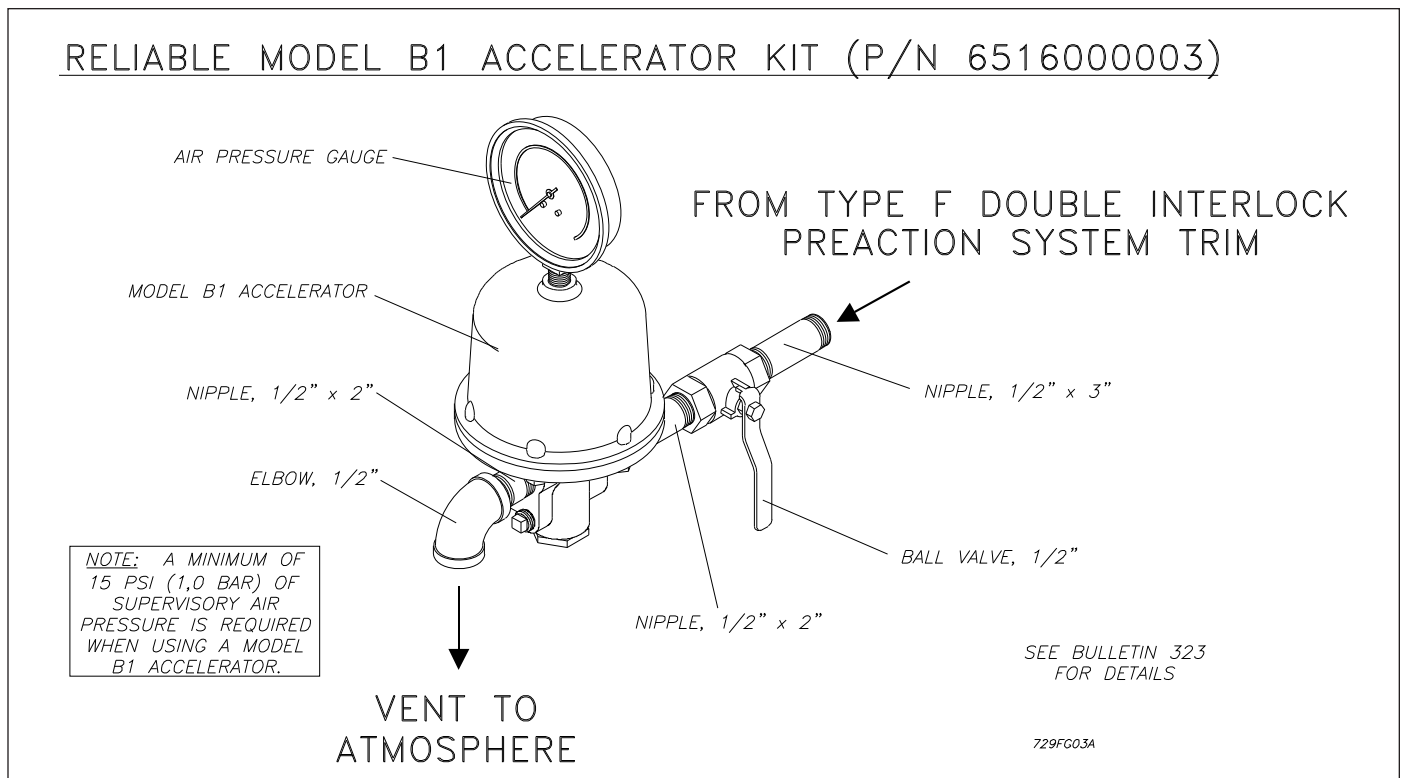

Fig. 3

System Operation

When set correctly for service, the Model DDX Deluge Valve is hydraulically established to withhold the supply water from the sprinkler system piping. The Reliable Model DDX Deluge Valve is shown in both closed and open positions in Fig. 1. In the closed position, the supply pressure acts on the underside of the clapper and also on the push rod through the push rod chamber's inlet restriction. The resultant force due to the supply pressure acting on the push rod is multiplied by the mechanical advantage of the lever and is more than sufficient to hold the clapper closed against normal supply pressure surges.

Whenever a fire is detected (i.e. via thermal detector or manual emergency station) and a sprinkler head is opened, the Model DDX Deluge Valve's pushrod chamber will be vented to atmosphere through the chamber's outlet. Since the pressure cannot be replenished through the inlet restriction as rapidly as it is vented, the push rod chamber pressure falls instantaneously. When the push rod chamber pressure approaches approximately one-third of the supply pressure, the upward force of the supply pressure acting beneath the clapper overcomes the lever-applied force thereby opening the clapper.

Once the clapper has opened, the lever acts as a latch, preventing the clapper from returning to the closed position. Water from the supply flows through the Deluge Valve into the system piping. Water also flows through the Deluge Valve alarm outlet to the alarm devices.

After system shutdown, resetting the Model DDX Deluge Valve is quite simple. Doing so only requires pushing in and turning the reset knob at the rear of the valve (see Fig 1). The external reset feature of the Model DDX Deluge Valve provides a means for simple, economical system testing, which is one essential facet of a good maintenance program. The external reset feature does not, however, eliminate another important facet

of good maintenance, namely, periodic cleaning and inspection of the internal valve parts.

In the event that water builds up inside the valve due to condensate from the air supply system or water left inside from valve system testing, a drain is available for venting. After closing the main supply valve, a small valve over the drain cup can be opened slightly until the water inside the valve body and the main pipe column has drained. See the section titled "Draining Excess/Condensate Water From System" in this bulletin for the detailed procedure.

The Model B Manual Emergency Station (see Fig. 4) is also included in the Reliable Type F Double Interlock Preaction System trim set. It consists of an aluminum nameplate mechanically attached to a ball valve. The valve handle in its OFF position is guarded against accidental turning to the ON position (and system discharge) by a nylon cable tie provided with each trim kit. The cable tie is inserted, as shown in Fig. 4, after the system has been restored for operation. The nylon cable tie is designed to allow, in case of an emergency, forceful turning of the valve handle to the ON position. As an alternative to the Model B Hydraulic Manual Emergency Station, the Model A Hydraulic Manual Emergency Pull Box (see Reliable Bulletin 506) is also available and can be provided as an option.

Whenever ambient temperature conditions are high, the water temperature in the Model DDX Deluge Valve's pushrod chamber could possibly increase, thereby increasing the pressure in the chamber to values exceeding the rated pressure of the system. In an indoor installation where standard room temperatures are exceeded, a pressure relief kit may be needed. Pressure relief kit, P/N 6503050001, can be installed into the pushrod chamber's releasing line to limit the pressure to 175 psi (12,1 bar).

MODEL B HYDRAULIC MANUAL EMERGENCY STATION

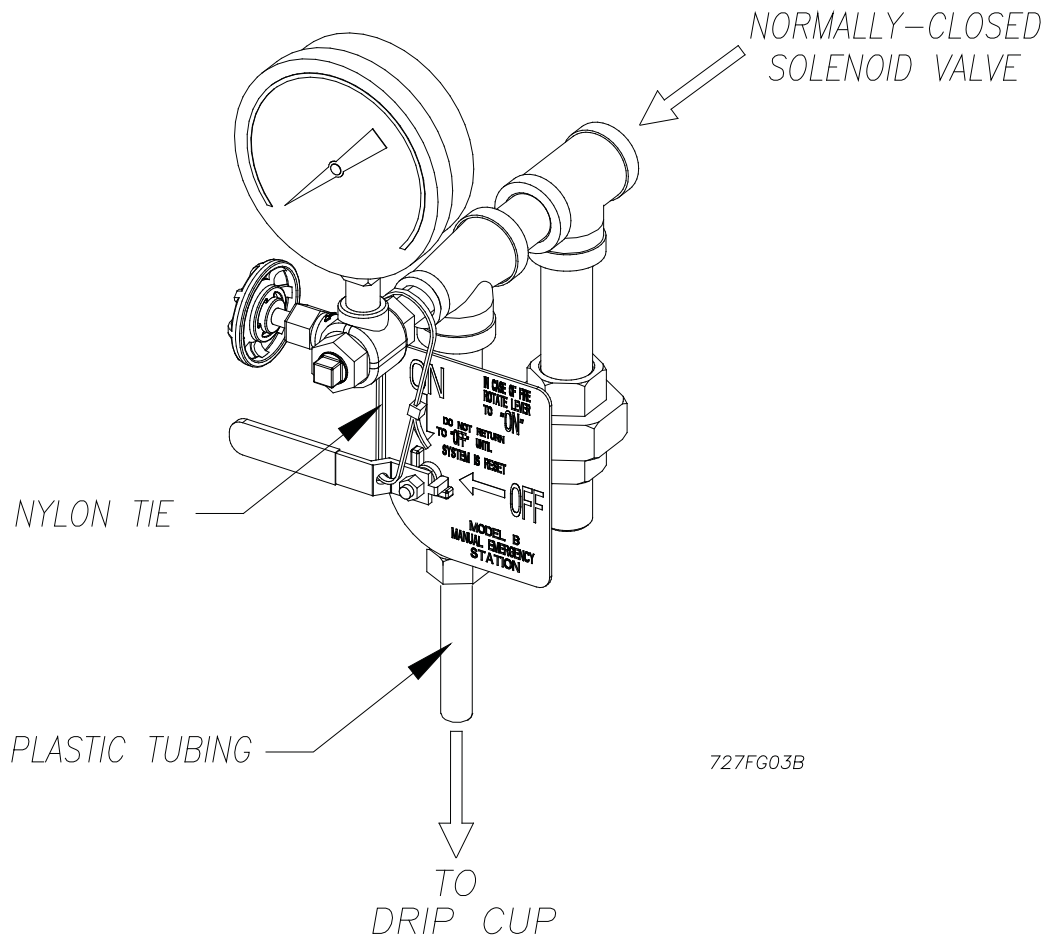

Fig. 4

Pressurizing Line Connection

The water supply for the push-rod chamber must be provided by connection of its inlet pressurizing line to the water supply piping. Pressurizing lines for multiple Model DDX Deluge Valve push-rod chambers must never be manifolded together, having only a single tap on the water supply piping. Each Model DDX Deluge Valve must have its own push-rod chamber pressurizing line connection. This connection must be made on the supply side of the main water supply control valve. This can be accomplished by:

- Using a tapped connection directly below or next to the main water supply control valve using a welded outlet or the appropriate mechanical fittings. A grooved-end outlet coupling is one way to achieve this (see Fig. 2); or
- Using a water supply control valve that has an available threaded (NPT) supply-side tap design to allow for a direct water supply connection to the Model DDX Deluge Valve's push-rod chamber.

Caution: Reliable's DDX valve is designed with an inlet restriction built into the pushrod chamber. It is important not to introduce additional restrictions into the direct water supply connection or the discharge from the pushrod chamber by installing additional valves or improperly installing the copper lines used in the trim of the valve.

System Design Considerations

The automatic sprinklers, air compressor, releasing devices, electric releasing control equipment, fire detection devices, manual pull stations, and signaling devices which are utilized with the Type F Double Interlock Preaction System must be UL or ULC Listed or FM Approved, as applicable.

Factory Mutual requires that detection devices in refrigerated areas be of the fixed temperature type. In addition, they must have a temperature rating lower than that of the sprinklers and preferably, as low as possible for the given ambient conditions.

The Deluge Valve, and all interconnecting piping must be located in a readily visible and accessible location and in an area that can be maintained at a minimum temperature of 40°F (4°C).

Note: Heat tracing is not permitted.

Pendent sprinklers, other than dry pendants, used on preaction systems shall be installed on return bends per NFPA 13.

The solenoid valve is operated and supervised by the electrical releasing/control panel. Details on the electrical portion of this system can be found in Reliable Bulletin 700, "Special Hazards & Special Systems".

Hydrostatic Testing of DDX Valves and DDX Systems

As required by NFPA 13, fire sprinkler systems with working pressures up to and including 150 psi are to be hydrostatically tested at a water pressure of 200 psi and maintain that pressure without loss for two hours. Fire sprinkler systems with working pressures above 150 psi are required to be hydrostatically tested at 50 psi above the system working pressure and maintain that pressure without loss for two hours. In addition to the hydrostatic tests described above, dry pipe and double interlock preaction systems require an additional low pressure air test.

In some cases, hydrostatic testing (in accordance with the NFPA 13 requirements noted above) will result in pressures that exceed the working pressure of the valve and trim kit for the two-hour test period. The valve and applicable trim kit have been tested, approved and listed under these conditions and as such, hydrostatic testing in accordance with NFPA 13 is acceptable. In addition, the clapper can remain in the closed position and the trim kit need not be isolated, as each has been designed to withstand hydrostatic testing as required by NFPA 13.

Hydrostatically testing the valve and trim to pressures higher than their rating is limited to the hydrostatic test as referenced by NFPA 13. It does not address the occurrence(s) of a “water hammer” effect, which can indeed damage the valve. A “water hammer” in the water supply piping of the valve can create pressures in excess of the rated pressure and should be avoided by all necessary means. This condition may be created from improper fire pump settings, underground construction work, or an improper venting of trapped air in the water supply piping.

System Air / Nitrogen Pressure Requirements

The Type F Double Interlock Preaction System trim includes gauges to read the pneumatic and water pressures of Model LP Dry Valve Actuator. Table A specifies the air or nitrogen pressure level to be applied to the Actuator. Optional Reliable Model A-2 or B-2 Pressure Maintenance Devices (see Reliable Bulletins 250 & 251) automatically provide a safeguard against pressure leaks in the sprinkler piping, and properly restricts the flow of makeup air.

When the optional Model B1 Accelerator is used, a Model A-2 Pressure Maintenance Device and a tank-mounted air compressor are required (see Fig. 9). Also, when a Model B1 Accelerator is used to expedite water-delivery time, the pneumatic pressure must be not less than 15 psi (1,0 bar).

Water Pressure psi (bar)	Pneumatic Pressure to be Pumped into Sprinkler System, psi (bar)	
	Maximum	Not Less Than
20 (1,4)	10 (0,7)	14 (0,9)
50 (3,4)	12 (0,8)	16 (1,1)
75 (5,2)	13 (0,9)	17 (1,2)
100 (6,9)	15 (1,0)	19 (1,3)
125 (8,6)	16 (1,1)	20 (1,4)
150 (10,3)	17 (1,2)	21 (1,4)
175 (12,1)	18 (1,2)	22 (1,5)
200 (13,8)	19 (1,3)	23 (1,6)
225 (15,5)	21 (1,5)	25 (1,7)
250 (17,2)	22 (1,5)	26 (1,8)

Note: During system set-up, a higher pneumatic pressure may be required in order to properly set the Model LP Dry Valve Actuator. The dew point of the air supply must be maintained below the lowest ambient temperature to which the preaction system will be exposed. Otherwise, accumulation of water (condensate) on the air side of the Actuator can lower the air pressure at which the Actuator opens, and possibly prevent proper system operation. Also, introduction of moisture into the system piping exposed to freezing temperatures can create ice blockage, which could prevent proper system operation. As a minimum, the supply of air should be taken from the area of lowest temperature within the protected area. The air supply system must be carefully designed to prevent plugging by frost deposits. Special requirements, such as those in FME&R’s “Installation Guidelines for Refrigerated Storage” may need to be incorporated.

Nitrogen used in refrigerated area systems minimizes a possibility of ice build-up and blockage inside the system piping that could inhibit proper system operation. The dewpoint of nitrogen compressed to 20 psig (1,4 bar) pressure is -46°F (-43,3°C), and -52°F (-46,7°C) when compressed to 10 psig (0,7 bar). High-pressure nitrogen cylinders can typically be rented from a local source, with rental fees varying by supplier and cylinder sizes. Typical cylinders are described in Table B. The calculated nitrogen supply in lbs (kg) to pressurize various system capacities to 10 psi (0,7 bar) at different freezer temperatures is shown in Table C.

Table B

Cylinder size	“Q”	“S”	“K”	“T”
Nitrogen Weight lbs. (kg)	5.50 (2.50)	10.28 (4.66)	16.51 (7.50)	22.01 (9.98)
Nitrogen Volume cu. ft. (m3)	76 (2.2)	142 (4.0)	228 (6.5)	304 (8.6)
Pressurized at psi (bar)*	2200 (151.7)	2200 (151.7)	2200 (151.7)	2460 (182.0)

Note: Initial pressure and thus nitrogen weight and volume can vary slightly. Check with your local supplier.

Table C

System Capacity Gal. (L)	Freezer Temperature					Approx. Fill Time (min.)*
	20°F (-6.7°C)	0°F (-18°C)	-20°F (-29°C)	-40°F (-40°C)	-60°F (-51°C)	
250 (946)	1.90 (.86)	1.90 (.86)	2.00 (.90)	2.10 (.95)	2.20 (1.00)	1
500 (1891)	3.64 (1.65)	3.80 (1.72)	4.00 (1.81)	4.20 (1.91)	4.40 (2.00)	2
750	5.50	5.70	6.00	6.30	6.60	3
1,000 (3785)	7.30 (3.30)	7.60 (3.44)	8.00 (3.62)	8.33 (3.78)	8.80 (4.00)	4

Note: To obtain required nitrogen supply (lbs.) for 15 psi (1,0 bar) or 22 psi (1,5 bar), multiply the tabulated values by a factor of 1.5 or 2.2 respectively.

(1 bar = 100 kPa)

* When filled with the Reliable Model A-2 Pressure Maintenance Device having the bypass valve open.

Whenever multiple Preaction Systems are installed at the same location, it is strongly recommended that each system have its own Model A-2 Pressure Maintenance Device for individual Maintenance of air pressure.

TYPE F DOUBLE INTERLOCK PREACTION SYSTEM ELECTRICAL CONNECTIONS

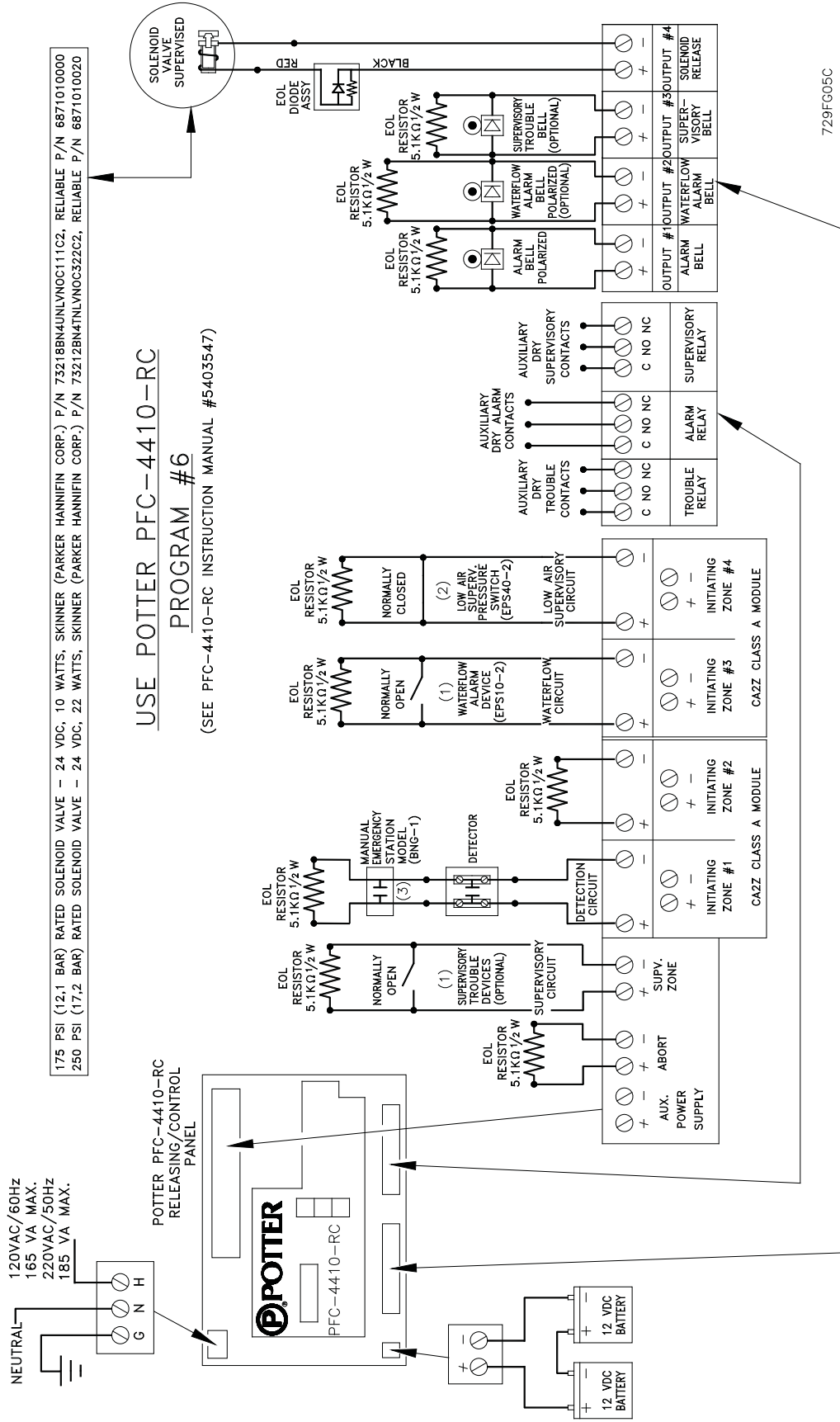

USE POTTER PFC-4410-RC
PROGRAM #6
(SEE PFC-4410-RC INSTRUCTION MANUAL #5403547)

175 PSI (12.1 BAR) RATED SOLENOID VALVE - 24 VDC, 10 WATTS, SKINNER (PARKER HANNIFIN CORP.) P/N 73218BN4UNLVNOC111C2, RELIABLE P/N 6871010000
250 PSI (17.2 BAR) RATED SOLENOID VALVE - 24 VDC, 22 WATTS, SKINNER (PARKER HANNIFIN CORP.) P/N 73212BN4TNLVNOC322C2, RELIABLE P/N 6871010020

- (1) THESE DEVICES MUST HAVE CONTACTS OPEN DURING THE NORMAL "SYSTEM READY" CONDITION.
- (2) THIS DEVICE MUST HAVE CONTACTS CLOSED DURING THE NORMAL "SYSTEM READY" CONDITION.
- (3) A MANUAL PULL STATION ON INITIATING ZONE #1 WILL ENERGIZE THE SOLENOID VALVE AND SOUND AN ALARM. USE THIS MANUAL PULL STATION TO SET UP SYSTEM.

Fig. 5

System Electrical Requirements & Low Air/Nitrogen

Pressure Supervision

All releasing (solenoid valve) and detection devices in Type F Double Interlock Preaction Systems are operated and supervised by the Potter PFC-4410-RC Releasing/Control Panel in accordance to the wiring diagram shown in Fig. 5. The Releasing/Control Panel should be set to use Program #6 (see Potter Instruction Manual #5403550). The double interlock function is achieved by the operation of the Model LP Dry Valve Actuator (due to sprinkler operation) in combination with the single interlock operation. Refer to Bulletin 700 "Special Hazards & Special Systems" for additional installation information.

A System Sensor pressure switch, Model EPS10-2, is provided with the Type F Double Interlock Preaction System trim for low air pressure supervision. The electrical rating for this pressure switch is 10.0 A, hp @ 125/250 VAC; 2.5 A @ 6/12/24 VDC. Wiring from the screw terminals marked "B" and "C" on the pressure switch, the low air supervisory circuit, can be wired back to the releasing/control panel's input #4. This will provide a supervisory signal for identifying a low air pressure supply condition at 4 to 8 psi (0,3 to 0,4 bar) decreasing pressure. Remote annunciation of this supervisory signal is achieved by wiring from the "NO" and "COM" terminals of Supervisory Relay Contacts, within the Potter PFC-4410-RC Releasing/Control Panel to the building's main fire alarm panel.

The power supply, the standby emergency power supply, battery charger, and the rectifier circuitry are all contained within the Potter PFC-4410-RC Releasing/Control Panel. Potter PFC-4410-RC Releasing/Control Panel requires 120 VAC. Batteries that provide ninety hours of standby power are required for FM Approved systems. The Model BNG-1 Manual Emergency Station can be connected as a simple detector for fire annunciation.

Caution: Repairs or disassembly of the solenoid valve should only be done by a trained technician. An improperly repaired or partially assembled solenoid valve could result in failure of the valve to operate.

Double Interlock Preaction System– Electric/Pneumatic Release Trim (Type F) Engineering Specifications

General Description

Preaction system shall be a double interlock preaction system utilizing a [4" (100 mm)] [6" (150 mm)] [165mm] [cULus Listed] [FM Approved] hydraulically operated, differential latching clapper-type valve with pneumatic/electric release preaction trim. Deluge valve shall be of lightweight, ductile-iron construction with "drop in" bronze seat and clapper assembly. Bronze seat shall have O-ring seals to resist corrosion and leakage. Clapper facing shall be pressure actuated, providing a limited compression seat for the sealing force between the clapper rubber facing and the valve seat. Push-rod chamber shall be of a piston/push-rod design with diaphragm seal and have a 1/4" vent hole for air/water leakage indication. Trip ratio shall be a 3:1 force differential. Deluge valve shall be of the straight-through design to minimize friction loss, and be capable of being reset without

having to remove the valve cover plate through the use of an external reset knob. Inlet restriction orifice shall be factory installed into inlet port of deluge valve push-rod cover plate and not be a separate part of the deluge valve trim. Valve end connections shall be grooved outlets per ANSI/AWWA C606. Deluge valve shall have a rated working pressure of 250 psi (17,2 bar). Deluge valve to be [4" (100 mm)] [6" (150 mm)] [165mm] Reliable Model DDX Deluge Valve (Bulletin 511).

Valve trim shall be Type F pneumatic/electric release trim consisting of the following:

- Hydraulic trim shall be galvanized and brass components specifically Listed/Approved with the deluge valve, including an emergency release valve and 2" main drain. Deluge valve's releasing devices shall be an electrical two-way, normally-closed, pilot operated solenoid valve [cULus Listed] [FM Approved] for its intended use, and a low-pressure pneumatic actuator.
- The solenoid valve shall be constructed of a brass body with stainless steel sleeve tube, springs, stop and plunger, and with 1/2" female NPT end connections. Solenoid valve shall have a maximum working pressure of [175 psi (12,1 bar)] [250 psi (17,2 bar)] and maximum ambient temperature rating of 150°F (66°C). Power consumption of integrated coil shall be limited to [10 watts (175 psi (12,1 bar) Rated)] [22 watts (250 psi (17,2 bar) Rated)] and require 24 VDC from a releasing/control panel listed for such service. Solenoid valve shall be a Skinner 1/2" normally-closed solenoid valve, [Model 73218BN4UNLVNOC111C2 (175 psi (12,1 bar) Rated)] [Model 73212BN4TNLVNOC322C2 (250 psi (17,2 bar) Rated)].
- The low-pressure, pneumatic actuator shall be of cast iron construction utilizing a diaphragm and compression spring design to separate the push-rod chamber water pressure from the system piping's pneumatic supervisory pressure. The low-pressure actuator shall only require between 10 and 26 psi (0,7 to 1,8 bar) supervisory pressure for proper setting in accordance with the manufacturer's instructions. Low-pressure pneumatic actuator shall be Reliable Model LP Dry Valve Actuator.
- The low air supervisory pressure switch to indicate loss of air pressure in system piping shall be [cULus Listed] [FM Approved] and of the bellows-activated type enclosed in a weatherproof, 4x, NEMA 4-rated enclosure incorporating tamper-resistant screws. There shall be two sets of SPDT (Form C) contacts rated at 10.0 A @ 125/250 VAC and 2.5 A @6/12/24 VDC. The pressure switch shall have a maximum service pressure rating of 250 psi (17,2 bar). Switch shall be provided with a 1/2" NPT male pressure connection. Low air supervisory pressure switch shall be System Sensor EPS40-2.

Double Interlock Preaction System shall be a Reliable Double Interlock Type F Preaction System, Bulletin 729.

Supervisory Air Supply Options

Owner's Air Supply

Supervisory air supply shall be provided by an owner supplied air system in conjunction with a [cULus Listed] [FM Approved] automatic pressure maintenance device, capable of maintaining a constant system pressure regardless of pressure fluctuations in the compressed air source. The pressure maintenance device shall consist of galvanized trim and brass parts, including a strainer and a field adjustable air pressure regulator, and have a working pressure rating of 175 psi (12,1 bar). The pressure regulator shall have an adjustable outlet pressure range of 5 to 50 psi (0,34 to 3,4 bar). Pressure maintenance device shall be Reliable Model A-2.

Compressed Air Supply

Supervisory air supply shall be provided by an automatic tank-mounted air compressor sized for the capacity (volume) of the double interlock preaction system piping, and be capable of restoring normal air pressure in the system within 30 minutes. Double interlock preaction system shall only require between 10 and 26 psi (0,7 to 1,8 bar) supervisory pressure for proper setting of the low pressure pneumatic actuator in accordance with the manufacturer's instructions. Air supply shall be equipped with an automatic pressure maintenance device capable of maintaining a constant system pressure regardless of pressure fluctuations in the compressed air (or nitrogen) source, or system piping. The pressure maintenance device shall consist of galvanized trim and brass parts, including a strainer and a field adjustable air pressure regulator, and have a working pressure rating of 175 psi (12,1 bar). The pressure regulator shall have an adjustable outlet pressure range of 5 to 50 psi (0,34 to 3,4 bar). Pressure maintenance device shall be Reliable Model A-2.

Nitrogen

Nitrogen cylinders provided by an approved source shall provide the nitrogen supply. Double interlock preaction system shall only require between 10 and 26 psi (0.7 to 1.8 bar) supervisory pressure for proper setting of the low pressure pneumatic actuator in accordance with the manufacturer's instructions. The nitrogen cylinder pressure shall be regulated and supervised through the use of nitrogen regulating device and low-pressure trim kit. This device shall consist of a brass, single stage pressure regulator, equipped with high pressure inlet and low pressure outlet gauges, and 1/4" copper connection tubing with galvanized 3/4" x 1/4" reducer bushing. Optional: Low-pressure trim kit shall be included to monitor the regulated nitrogen supply pressure to provide a low-pressure supervisory alarm. This kit shall include a low-pressure switch with associated galvanized connection trim. Assembly shall be a Reliable Nitrogen Regulating Device. This device is to be used in conjunction with the Reliable Model A-2 Pressure Maintenance Device.

Optional System Accessories

System Control Valve

Preaction system control valve shall be a slow close, [cULus Listed] [FM Approved] indicating butterfly type valve with a pre-wired supervisory tamper switch assembly. The valve shall be rated for a working pressure of [175 psi (12,1 bar)] [250 psi (17,2 bar)]. System control valve shall be a [4" (100 mm)] [6" (150 mm)] [165mm] Nibco GD-4765-8N Butterfly Valve.

Detection System

To initiate actuation of the preaction system's deluge valve, a supplemental electric detection system shall be provided [Insert applicable product specification]

Releasing/Control Panel

A [cULus Listed] [FM Approved] releasing/control panel shall be used to operate the preaction system. The releasing/control panel shall be a conventional, microprocessor-controlled panel containing two initiating device circuits, and waterflow and supervisory inputs. Output circuits shall include alarm, waterflow, supervisory, and releasing circuits. The releasing/control panel shall be capable of providing any of the following desired modes of operation: single hazard, two zone; single hazard, cross-zoned; dual hazard, combined release; and dual hazard, split release (two area). Type F double interlock system shall require the single hazard mode of operation. Releasing/control panel shall be equipped with a local tone alarm to annunciate loss of AC power; system trouble, circuit trouble, and low auxiliary DC power supply. Panel shall be [cULus Listed] [FM Approved] and be capable of providing power for compatible detectors and auxiliary devices used. Audible alarms shall be able to be silenced at releasing panel. Auxiliary DC power supply shall consist of (2) 12-volt lead acid batteries of the same ampere-hour rating, providing [60 hours – cULus Listed] [90 hours – FM Approved]. Dry contacts shall be provided for remote annunciation of alarm, trouble, and supervisory panel signals. Main power supply to be a dedicated 120 VAC / 60Hz circuit.

Accelerator

For system capacities in accordance with NFPA 13, an accelerator with associated galvanized trim kit shall be provided to exhaust air pressure from the pneumatic actuator trim piping in order to hasten operation of the double interlock preaction system. Minimum pneumatic pressure shall be 15 psi (1,0 bar) to ensure proper accelerator operation. Accelerator shall be [cULus Listed] [FM Approved] for use with the double interlock preaction trim. Accelerator shall be capable of adjusting for small fluctuations in system air pressure without causing operation. The accelerator shall contain an integral Accelo-Check (anti-flooding) assembly to prevent entry of water and debris into critical internal areas during operation. Accelerator body and dome to be of cast aluminum and epoxy coated inside and out. Diaphragm construction shall consist of Dupont Fairprene BN 5049 with stainless steel filter assembly. Trim kit shall consist of all galvanized and brass parts, including an isolating ball valve. Accelerator and trim kit shall be Reliable Model B1 Accelerator Trim Kit.

Waterflow Alarm Pressure Switch

Alarm pressure switch shall be provided to indicate water flow and provide a water flow alarm. Pressure switch shall be [cULus Listed] [FM Approved] and of the bellows activated type enclosed in a weatherproof, 4x, NEMA 4-rated enclosure incorporating tamper-resistant screws. There shall be two sets of SPDT (Form C) contacts rated at 10.0 A @ 125/250 VAC and 2.5 A @ 6/12/24 VDC. The pressure switch shall have a maximum service pressure rating of 250 psi (17,2 bar) and shall be factory adjusted to operate at a pressure of 4 to 8 psi (0,27 to 0,55 bar) with adjustment up to 20 psi (1,3 bar). Switch shall be provided with a 1/2" NPT male pressure connection. Waterflow alarm pressure switch shall be System Sensor EPS10-2.

Technical Data

Reliable Type F Double Interlock Preaction Systems, with associated trim, sizes 4" (100mm), 6" (150mm) and 165mm are rated for use at a minimum water supply pressure of 20 psi (1,4 bar) and a maximum supply pressure of 250 psi (17,2 bar). Water supplied to the inlet of the valve and to the pushrod chamber must be maintained between 40°F (4°C) and 140°F (60°C).

Deluge Valve	Reliable 510/511
Hydraulic Emergency Station (Model A)	Reliable 506
Solenoid Valve	Reliable 718
Mechanical Sprinkler Alarm	Reliable 612/613
Pressure Maintenance Device	Reliable 250/251/253
Nitrogen Regulating Device	Reliable 253
Air Compressor	Reliable 700
Releasing/Control Panel	Potter #5403550
Electric Emergency Station	Reliable 700
Thermal Detectors	Reliable 722
Fire Alarm Devices	Reliable 700
Model B1 Accelerator Trim Kit	Reliable 323
Low Air Pressure Supervisory Switch	System Sensor A05-0176
Waterflow Pressure Alarm Switch	System Sensor A05-0176

Valve Description

- Rated working pressure:
 - Valve & System- 250 psi (17,2 bar)
- Factory tested to a hydrostatic pressure of 500 psi (34,5 bar). (Valve only)
- End and trim connections:
 - ANSI/AWWA C606 grooved inlet and outlet

Groove Dimensions				
Valve Size	Outlet Diameter	Groove Diameter	Groove Width	Outlet Face to Groove
4" (100 mm)	4.500" (114 mm)	4.334" (110 mm)	3/8" (10 mm)	5/8" (16 mm)
6" (150 mm)	6.625" (168 mm)	6.455" (164 mm)		
165 mm	6.500" (165 mm)	6.330" (161 mm)		

- Threaded openings Per ANSI B 2.1/8

Valve Size	Color
4" (100 mm) 6" (150 mm)	Black
165 mm	Red

- Face to face dimensions:
 - 4" (100 mm) — 14" (355 mm)
 - 6" (150 mm) & 165mm — 16" (406 mm)
- Shipping weight:

Valve Size	Weight
4" (100 mm) 6" (150 mm) & 165 mm	64 lb. (29 kg) 95 lb. (43 kg)

- Friction loss (Expressed in equivalent length of Schedule 40 pipe, based on Hazen & Williams formula with C=120 and a flow velocity of 15ft/sec (4.6 m/sec)):

Valve Size	Equivalent Length
4" (100 mm) 6" (150 mm) & 165 mm	14' (4.27 m) 29.4' (9 m)

- Installation position: Vertical

Maintenance

Reliable Type F Double Interlock Preaction Systems and associated equipment shall periodically be given a thorough inspection and test. NFPA 25, Inspection, Testing and Maintenance of Water Based Fire Protection Systems, provides minimum maintenance requirements. System components shall be tested, operated, cleaned, and inspected at least annually, and parts replaced as required.

Resetting the Type F Double Interlock Preaction System

Refer to Figs. 2, 6, and 7.

1. Close the main valve controlling water supply (Fig. 7) to the Deluge Valve and close off the air/nitrogen supply to the sprinkler system.
2. Close the pushrod chamber supply valve, valve A (Fig. 7).
3. Open the main drain valve, valve B (Fig. 7), and drain system.
4. Open all drain valves and vents at low points throughout the system, closing them when flow of water has stopped. Open valve D (Fig. 7). **Note:** The above steps accomplish the relieving of pressure in the pushrod chamber of the Deluge Valve.
5. With Valve F (Fig. 7) open, push in the plunger of ball drip valve, valve G (Fig. 7), to force the ball from its seat, and drain any water in the alarm line.
6. With the Model B Manual Emergency Station, valve D (Fig. 7), open, push in and rotate the Deluge Valve's external reset knob (#38, Fig. 6) clockwise until you hear a distinct clicking noise, indicating that the clapper has closed. **Note:** The reset knob can be rotated only after pressure in the pushrod chamber is reduced to atmospheric conditions (0 psig).
7. Inspect and replace any portion of the sprinkler system subjected to fire conditions.
8. Close valve F (Fig. 7). Activate a solenoid-release pull station (Or other means of electric detection. Refer to Bulletin 700, "Special Hazards & Special Systems") to energize the solenoid valve. Silence any alarms or audible tones by pressing the "Remote Silence" and/or "Local Silence" buttons on the releasing/control panel. Open valve A (Fig. 7) to begin pressurizing the push-rod chamber and its associated piping, while simultaneously venting any entrapped air. **Note:** This venting of the air from the actuation piping is very important to ensure proper system operation and avoidance of falsely tripping the Deluge Valve.
9. Upon seeing a solid flow of water from the drain tubing, and the cessation of the "gurgling" sound at the drip cup, H (Fig. 7), close valve D (Fig. 7) then rapidly apply compressed air or nitrogen into the Model LP Dry Valve Actuator (and the sprinkler system) until the pressure conforms to Table A levels as indicated on the air pressure gauge (Fig. 7). The Model LP Dry Valve Actuator will close during this pressurizing process and the water will stop flowing into the drip cup. **Note:** It may be necessary to temporarily close the main drain (valve B, Fig. 7) in order to build sufficient air pressure to "set up" the Model LP Actuator. Once the Model LP Actuator is "set up", the main drain (valve B, Fig. 7) should be reopened and the remaining procedure followed. At this point, the pressure gauge which indicates push-rod chamber pressure (Fig. 7) will equalize to the available water supply pressure. **Note:** It may be necessary to isolate the system pressure gauge in the supply line to the Model LP Dry Valve Actuator during system set-up by closing the 1/4" 3-way valve (#62, Fig. 2). During set-up, pressure fluctuations may occur that can be potentially damaging to the gauge.

10. De-energize the solenoid valve. This is accomplished by resetting the manual emergency station and/or detectors prior to resetting the releasing/control panel (Refer to Bulletin 700, "Special Hazards & Special Systems"). **Note:** All detection devices must be reset before the releasing/control panel can be reset.
11. If it is being used, reset the Model B1 Accelerator per Reliable Bulletin 323. **Note:** The Model B1 Accelerator requires a minimum of 15 psi (1.0 bar) for proper operation.
12. Open valve F (Fig. 7). Open slightly the main valve controlling water supply (Fig. 7) to the Model DDX Deluge Valve, closing drain valve B (Fig. 7) when water flows. Observe if water leaks through the ball drip valve, valve G (Fig. 7), into the drip cup, H (Fig. 7). If no leak occurs, the Deluge Valve's clapper is sealed. Open slowly, and verify that the main valve controlling water supply is fully opened and properly monitored.
13. Verify that valve A (Fig. 7) and valve F (Fig. 7) are open.
14. Secure the handle of the Model B Manual Emergency Station, valve D (Fig. 7), in the OFF position with a nylon tie (#55, Fig. 2).

Inspection and Testing

Refer to Figs. 2, 6, and 7.

1. **Water supply** — be sure the valve(s) controlling water supply to the Deluge Valve are opened fully and properly monitored.
2. **Alarm line** — be sure that valve F (Fig. 7) is opened and remains in this position.
3. **Other trimming valves** — check that valve A (Fig. 7) is open as well as all of the pressure gauge's 1/4" 3-way valves. Valves D, E, and J (Fig. 7) should be closed.
4. **Ball drip valve G (Fig. 7)** — make sure that valve F (Fig. 7) is open. Push in on the plunger to be sure the ball check is off its seat. If no water appears, the Deluge Valve's water seat is tight. Inspect the bleed hole (see Fig. 6) on the underside of the push rod chamber for leakage.
5. **System pneumatic pressure** — check air pressure gauge (Fig. 7) and water supply pressure gauge (Fig. 7) for conformance to Table A.
6. **Releasing device** - Model LP Dry Valve Actuator (Fig. 7) — Verify that the outlet is not leaking water. Check the air pressure gauge (Fig. 7) for proper pressure setting. Verify that the tubing line from the Actuator is not pinched or crushed, which could prevent proper operation of the Deluge Valve.
7. **Testing alarms** — make sure that valve F (Fig. 7) is open. Open valve J (Fig. 7) permitting water from the supply to flow to the electric sprinkler alarm switch and to the mechanical sprinkler alarm (water motor). After testing, close this valve securely. Push in on the plunger of ball drip valve G (Fig. 7) until all of the water has drained from the alarm line.
8. **Operational test** — Open the Model B Manual Emergency Station, valve D (Fig. 7). Note: An operational test will cause the Deluge Valve to open and flow water into the sprinkler system.
9. Secure Model B Manual Emergency Station, valve D (Fig. 7), in the OFF position with a nylon tie (#55, Fig. 2) after the Deluge Valve is reset.

MODEL DDX DELUGE VALVE [4"(100MM), 6"(150MM) & 165 MM]

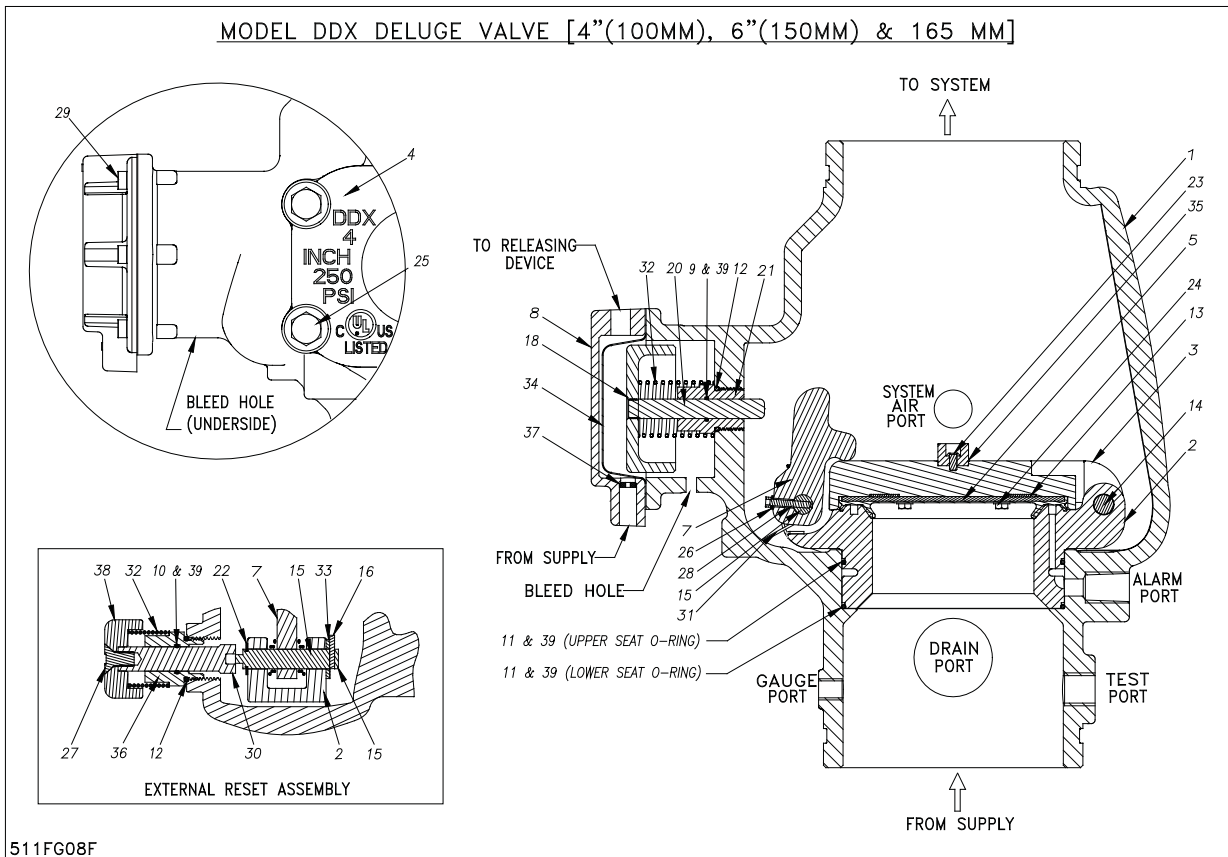

Fig. 6

Item. No	Part Number			Description	No Req'd
	4"(100mm) Valve	6"(150mm) Valve	165mm Valve		
1	91006005	91006007	91006027	Valve Body	1
2	96016004	96016006	96016006	Seat	1
3	91916004	91916006	91916006	Clapper	1
4	92116064	92116066	92116065	Cover	1
5	93416004	93416006	93416006	Seal Faceplate Subassembly	1
6	93706004	93706006	93706006	Gasket, Cover (Not Shown)	1
7	94506004	94506006	94506006	Lever	1
8		92126006		Cover, Pushrod	1
9		95406407		O-ring (014)	1
10		95406007		O-ring (114)	1
11	95406006	N/A		O-ring (156)	2
	N/A	95406016		O-ring (161)	
12		95406024		O-ring (912)	2
13	93706001	N/A	N/A	Gasket, Clapper, 4"	1
	N/A	93706002	93706002	Gasket, Clapper, 6"	1
14		96216086		Hinge Pin, Clapper	1
15		96216046		Pin, Lever	1
16		95606131		Threaded Stud, #10-32 x 3/4"	1
17		96216066		Pin, Locking, Seat (Not Shown)	2
18		95106006		Piston	1
19		95200038		Plug, Socket, Ø 3/8"-18 NPT (Not Shown)	2
20		95506006		Pushrod	1
21		93916006		Pushrod Guide	1
22		95306267		Ring, Retaining (2 Assembled to Item No. 14)	3

Item. No	Part Number			Description	No Req'd
	4"(100mm) Valve	6"(150mm) Valve	165mm Valve		
23		95606128		Screw, Button Head, #10-32 x 3/8"	1
24		95606129		Screw, Hex Washer Head, #10-32 x 3/8"	4
25	95606107	N/A	N/A	Screw, Hex Cap, Ø 1/2"-13 x 1 1/2"	6
25	N/A	91106006	91106006	Screw, Hex Cap, Ø 5/8"-11 x 1 3/4"	1
26		96906111		Spring Lock Washer, #10	1
27		95606127		Screw, C'sunk Cap Head, Ø 3/8"-16 x 3/4"	1
28		95606130		Screw, Socket Head, #10-32 x 1"	1
29		95606114		Screw, Socket Head, Ø 1/4"-20 x 5/8"	6
30		93916066		Shaft, Reset	1
31		96406004		Spring, Lever	1
32		96406906		Spring	2
33		96906904		Teflon Washer, Ø 1/2" (2 Assembled to Item No. 14)	3
34		95276006		Diaphragm	1
35		92306006		Disc, Bumper	1
36		94106066		Housing, Reset	1
37		94206406		Inlet, Orifice	1
38		94356006		Knob, Reset	1
39		85000050		O-ring Grease, DuPont™ Krytox® GPL-201	A/R

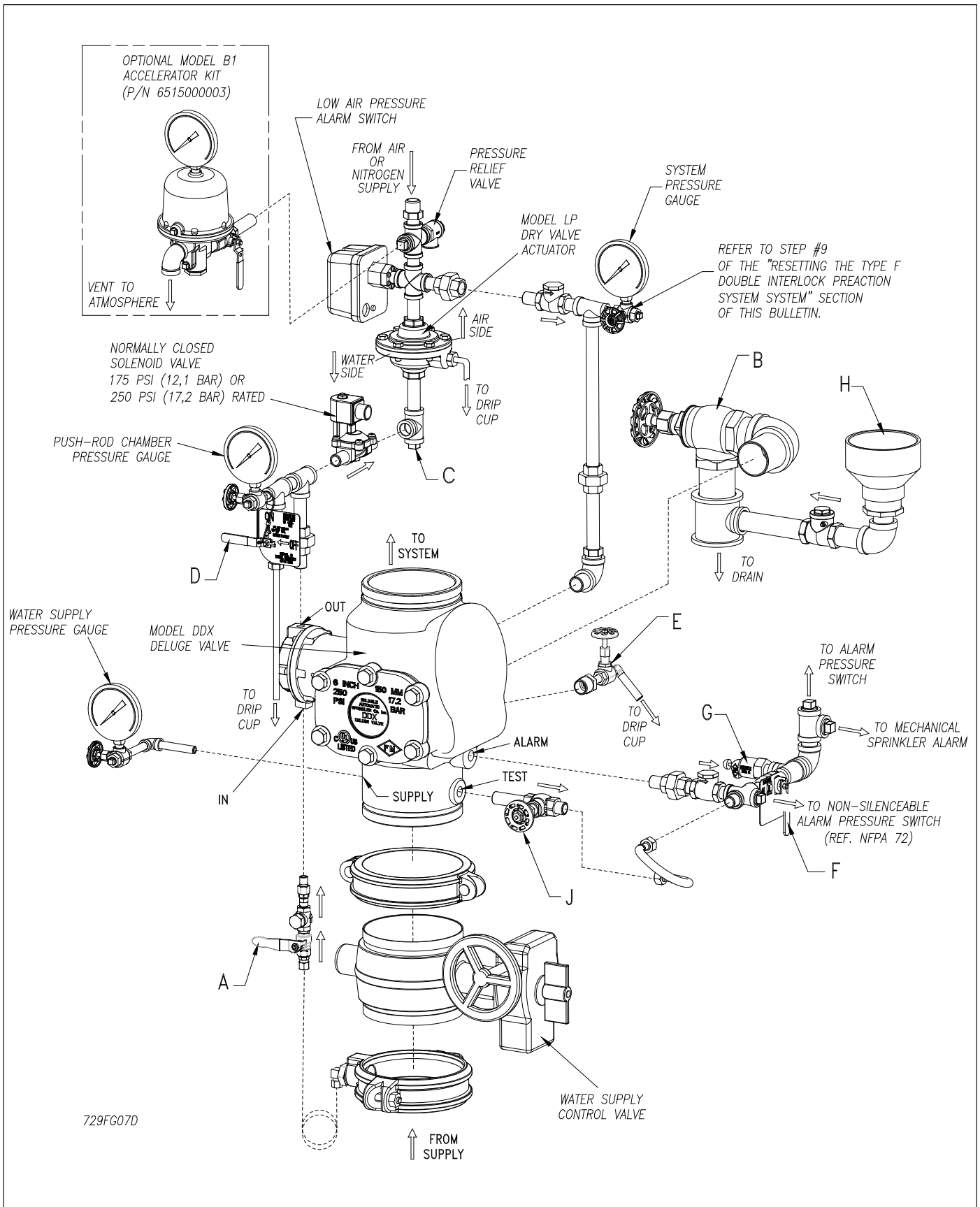

Fig. 7

Testing the Model DDX Deluge Valve Without Flowing Water

Refer to Fig. 7

1. Close the valve controlling water supply to Deluge Valve and open the main drain valve B.
2. Verify that valve A is open, allowing water to enter the push rod chamber.
3. Close off the air/nitrogen supply to the sprinkler system.
4. Decrease pneumatic pressure in the system by opening the 1/4" angle valve, valve E, until the Model LP Dry Valve Actuator operates. This will be indicated by a sudden drop of water pressure on the air pressure gauge. This operation of the Actuator will vent the water pressure from itself back to the solenoid valve which is still closed. The push-rod chamber of the Deluge Valve should still be pressurized at this point.
5. Operate detection system(s) by activating a solenoid-releasing manual emergency station (Or other means of electric detection. Refer to Bulletin 700, "Special Hazards & Special Systems") in order to energize the solenoid valve open.
6. Operation of the detection system will result in a sudden drop of water pressure in the push rod chamber.
7. Proceed according to the directions listed in the "Resetting the Type F Double Interlock Preaction System" section of this bulletin for resetting the Deluge Valve.

Draining Excess/Condensate Water From System

Refer to Fig. 7

1. Close the main valve controlling water supply to Deluge Valve. Also close valve A and open main drain valve B.
2. Open condensate drain valve E until all water has drained. Close valve E. **Note:** Be sure not to keep valve E open for an extended period of time because that will cause enough system air to bleed off thereby actuating the Model LP Dry Valve Actuator (see Table A for pneumatic pressure values required to maintain the Model LP Dry Valve Actuator closed for a given supply pressure). If the Actuator does happen to actuate, the entire system must be re-established in the correct order as to avoid any possibilities of false-tripping of the Deluge Valve. Proceed according to the directions listed in the "Resetting the Type F Double Interlock Preaction System" section of this bulletin.
3. Close main drain valve B. If system contains pressurized air, allow air pressure to come back up to specification. Open valve A first, and then open the main valve controlling the water supply to the Deluge Valve.

Maintenance Procedures- Model DDX Deluge Valve

Refer to Figs. 2, 6 & 7

1. Mechanical sprinkler alarm (water motor—not shown) not operating:

This is most likely caused by a clogged screen in the strainer of the water motor. Proceed as follows: Remove plug from the strainer. Remove and clean the screen. Replace the screen and the plug, and then tighten securely (Ref. Bulletin 613)

2. Leakage out of the ball drip valve G (Fig. 7).

a. Water leakage due to a water column above the Deluge Valve's clapper:

This condition can be caused by leakage past the system side of the Model DDX Deluge Valve's seal faceplate subassembly (#5, Fig. 6). Be sure that this surface is free of any type of debris. To eliminate leakage due to a water column, refer to the section in this bulletin marked "Draining Excess/Condensate Water From System". If the problem continues proceed to the following section.

b. Leakage, air or water from the ball drip valve, G (Fig. 7):

If system air is leaking out the ball drip valve, the problem is either damage to the airside of the Model DDX Deluge Valve's seal faceplate subassembly (#5, Fig. 6), seat (#2, Fig. 6), or the upper seat O-ring (#11, Fig. 6). If supply water is leaking out the ball drip valve the problem could be caused by damage to the Model DDX Deluge Valve's seal faceplate subassembly (#5, Fig. 6), seat (#2, Fig. 6), or lower seat O-ring (#11, Fig. 6). The following section provides instructions to correct both conditions: A) Shut down the valve controlling the water supply to the Deluge Valve and open the main drain valve B (Fig. 7). Open the water column drain valve E (Fig. 7). Close the push rod chamber supply valve A (Fig. 7) and open the Model B Manual Emergency Station D (Fig. 7). B) Remove the Deluge Valve's front (handhold) cover (#4, Fig. 6) and inspect the seat (#2, Fig. 6), clapper (#3, Fig. 6), and seal faceplate subassembly (#5, Fig. 6) for damage.

If inspection indicates damage to the clapper (#3, Fig. 6) or seal faceplate subassembly (#5, Fig. 6) only, then the clapper subassembly can be removed as follows:

At the rear of the valve, disconnect the water column drain trim section starting with the elbow connector (#18, Fig. 2). Then remove the 1/4" globe valve (#28, Fig. 2) followed by the 3/4" x 1/4" reducing bushing (#13, Fig. 5). Remove the retaining ring (handhold cover side) from the clapper hinge pin (#14, Fig. 6) and push this pin through the water column drain line and remove the clapper subassembly. Remove the four retaining screws (#24, Fig. 6) holding the seal faceplate subassembly (#5, Fig. 6). Inspect the clapper (#3, Fig. 6) visually before re-installing. Apply a small amount of silicone-based lubricant to the four retaining screws. Install a new seal faceplate subassembly. Torque the retaining screws to approximately 40 inch-pounds and reassemble. If the seat (#2, Fig. 6) is damaged or it is suspected that the leakage is through the lower O-ring (#11, Fig. 6), the seat-clapper subassembly is easily removed as a unit as follows:

Using a 5/16" Allen wrench, remove the two 3/8" NPT pipe plugs (#19 (not shown) Fig. 6) located on the side of the Model DDX Deluge Valve. The seat-clapper subassembly is retained by two locking pins (#17 (not shown) Fig.6). The centers of these pins have a 1/4"-20 threaded hole. Remove the two locking pins by engaging them with a 1/4"-20 screw or threaded rod and pulling them out (The two locking pins are not threaded, so turning them with the attached 1/4"-20 screw or threaded rod is not recommended. A proven method is to use 1/4"-20 threaded rod with a locknut on the unassembled end. Grab hold of the locknut with pliers or vice-grips and tap the pliers or vice-grips in the direction away from the Deluge Valve. Doing so should pull the locking pins out of the Deluge Valve.). With the clapper (#2, Fig. 6) in the closed position (not latched), dislodge the seat-clapper subassembly from the Valve's body by inserting two slotted screwdrivers under the lever and clapper mounting ears and pry up until the seat-clapper subassembly is free of its bore. Reach into the valve and grasp the seat-clapper subassembly from the sides. Lift up and rotate the seat-clapper subassembly through 90 degrees about the centerline axis of the Model DDX Deluge Valve so that the lever side of the seat-clapper subassembly faces the outlet of the Deluge Valve. Rotate the seat-clapper subassembly around the centerline of the Deluge Valve until the top of the clapper faces the handhold opening and then pull it out clapper hinge-pin side first. Visually examine all components of the seat-clapper subassembly replacing any component that appears damaged. New O-rings (#11, Fig. 6) should always be used for reassembly.

Reassembly:

It is likely that the lower seat O-ring (#11, Fig. 6) has remained at the bottom of the Deluge Valve body's bore. Discard this O-ring and clean the bore. Lubricate the bore with O-ring grease and place the lower seat O-ring on the step at the bottom of the bore, verifying that it is in full contact with the bore. Lubricate the bottom step and upper seat O-ring (#11, Fig. 6) of the refurbished seat-clapper subassembly. Insert the seat-clapper subassembly into the handhold opening of the Deluge Valve lever-first, rotating it until the lever side faces the outlet of the Deluge Valve. Rotate the seat-clapper subassembly until the lever (#7, Fig. 6) faces the push rod (#20, Fig. 6), then drop the seat-clapper subassembly into the Deluge Valve's bore. Verify that the seat-clapper subassembly is in the fully down position and check to see that the lever lines up with the push rod. Adjust if necessary. Clean and lubricate the two locking pins (#17(not shown) Fig.6) with O-ring lubricant and drive them into the Deluge Valve body. Then reinstall the 3/8" NPT pipe plugs (#19 (not shown) on Fig. 6). Reassemble the handhold cover and set up the Model DDX Deluge Valve as per the section "Resetting the Type F Double Interlock Preaction System."

3. Leakage out of the push rod chamber vent hole:

A small bleed hole is located on the underside of the push rod chamber (see Fig. 6). If there is air or water leakage coming out of this hole, do the following:

- a. Shut down the valve controlling water supply to the Deluge Valve. Relieve the inlet pressure by opening the main drain valve B (Fig. 7). Close the valve A (Fig. 7) that supplies water to the push rod chamber, and open the Model B Manual Emergency Station, valve D (Fig. 7).
- b. Remove the trim at the unions nearest to the push rod chamber cover (#8, Fig. 6).
- c. Take the push rod chamber cover (#8, Fig. 6) off by removing the six retaining screws (#29, Fig. 6).

CONDITION ONE (Water coming out of the bleed hole):

Water coming out of the bleed hole is caused by a leaking diaphragm (#34, Fig. 6). Visually inspect the push rod chamber cover (#8, Fig. 6) and piston (#18 Fig. 6) to determine what could have damaged the diaphragm and correct. Install a new diaphragm.

NOTE: The diaphragm has two different surfaces, it is not bi-directional. It will fail if installed backwards! Roll the diaphragm so that the smooth surface (the pressure side) conforms to the inside of the push rod chamber cover and reassemble the six retaining screws (#29, Fig. 6) with an installation torque of 15 foot-pounds. Set up the Model DDX Deluge Valve as per the section "Resetting the Type F Double Interlock Preaction System."

CONDITION TWO (System air coming out of the bleed hole):

System air coming out of the bleed hole is caused by a defective O-ring assembled to the push rod guide (#21, Fig. 6). Remove the piston-push rod subassembly, push rod spring (#32, Fig. 6), and push rod guide (#21, Fig. 6). Verify by hand turning, that the push rod cannot be unscrewed from the piston. Replace all O-rings and the push rod guide. The correct installation torque for the push rod guide is 35 inch-pounds.

CAUTION: Do not over-tighten the push rod guide. Reassemble the components that were initially removed. Re-install the diaphragm (#34, Fig. 6) if it appears to be in good shape, otherwise, replace it also.

NOTE: The diaphragm has two different surfaces, it is not bi-directional. It will fail if installed backwards! Roll the diaphragm so that the smooth surface (the pressure side) conforms to the inside of the push rod chamber cover and reassemble the six retaining screws (#29, Fig. 6) with an installation torque of 15 foot-pounds. Set up the Model DDX Deluge Valve as per the section "Resetting the Type F Double Interlock Preaction System."

MODEL LP DRY VALVE ACTUATOR

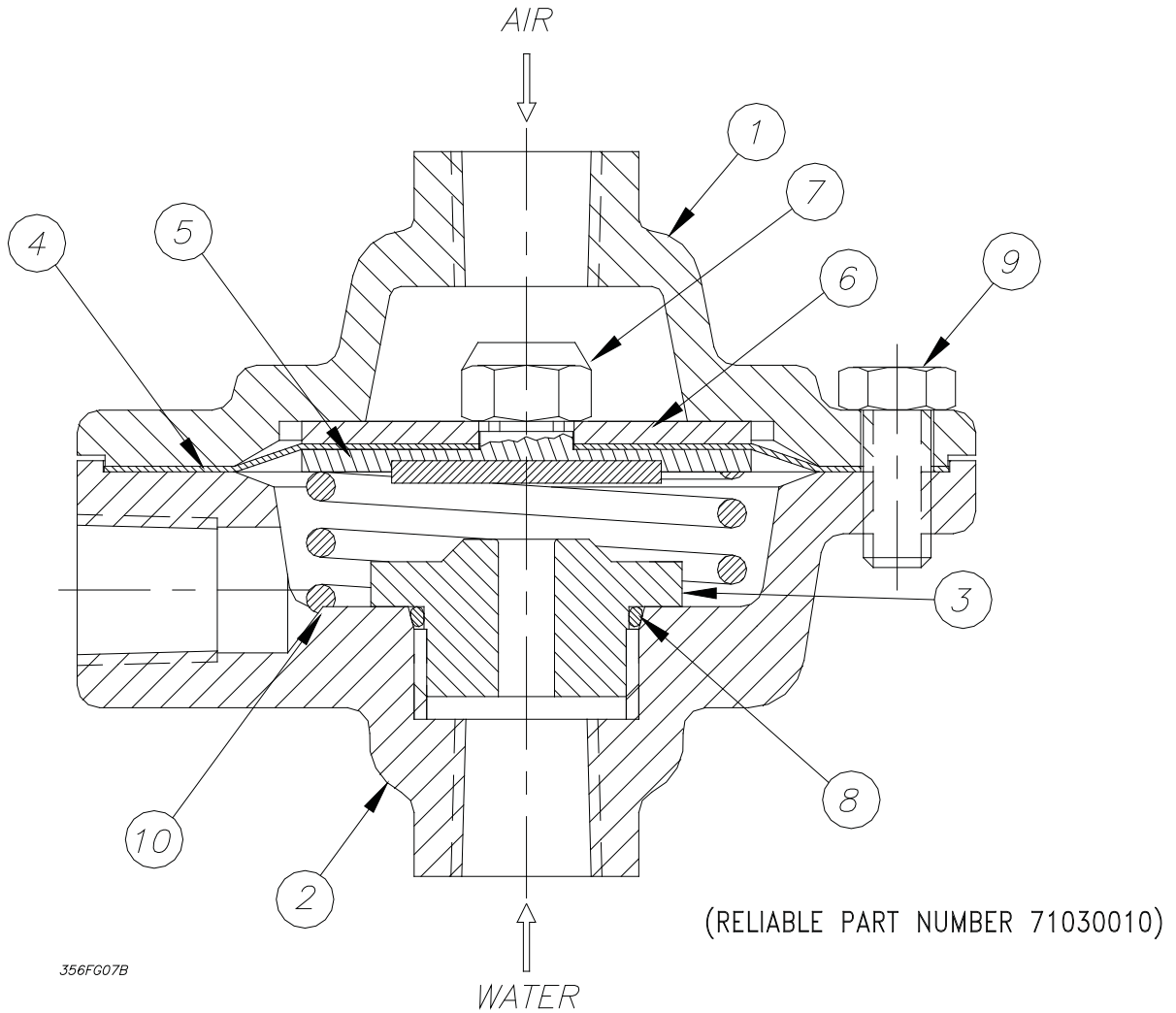

Fig. 8

Model LP Dry Valve Actuator Parts List P/N 71030010

Item No.	Part No.	Description	Qty. Required
1	94106936	Lower Housing	1
2	94106935	Upper Housing	1
3	96006905	Seat	1
4	92206311	Diaphragm	1
5	95106911	Facing Plate Assembly	1
6	96906311	Diaphragm Washer	1
7	94906406	Facing Plate Nut	1
8	95406901	Seat O-Ring	1
9	95606305	Bolt	6
10	96406902	Compression Spring	1

Maintenance – Model LP Dry Valve Actuator

Refer to Figs. 7 and 8

If water constantly flows through the Model LP Dry Valve Actuator and into the drain, there is a leak in the seal of the Actuator's seat.

1. Close the main valve controlling water supply (Fig. 7) to the Deluge Valve and close off the air/nitrogen supply to the sprinkler system. Close valve A (Fig. 7).
2. Drop pressure in the system by opening the 1/4" angle valve, valve E (Fig. 7), and remove the Actuator from the system.
3. Remove all six bolts (#9, Fig. 8) holding the Actuator together. Clean or replace the facing plate assembly (#5, Fig. 8) and seat (#3, Fig. 8).
4. Reassemble the Actuator, using a torque of 8 ft-lbs on the facing plate nut (#7, Fig. 8) and 12 ft-lbs on the six bolts (#9, Fig. 8). Use a cross-tightening pattern. Reinstall the Actuator. Set up the Model DDX Deluge Valve as per the section "Resetting the Type F Double Interlock Preaction System."

Ordering Information

Specify:

- **Valve Model & Size** — 4”(100mm) Model DDX Deluge Valve (P/N 6103040026), 6”(150mm) Model DDX Deluge Valve (P/N 6103060024), 165mm Model DDX Value (P/N 6103060028).
- **Trim** — The trim set is available in individual parts, in time-saving segmentally assembled kit forms, or fully assembled to the Model DDX Deluge Valve with or without a control valve.
- **Solenoid Valve** —175 psi (12,1 bar) or 250 psi (17,2 bar) Rated. Explosion-Proof Solenoid Valve available upon request.
- **Low Air Pressure Switch** — UL/FM Approved (System Sensor Model EPS40-2) or ULC Listed (System Sensor Model EPSA40-2).

		Trim Configurations	Trim Part Numbers		
			4” (100mm) Valve	6” (150mm) Valve	165mm Valve
UL/FM Approved Pressure Switch	175 psi (12,1 bar) Rated Solenoid Valve	Fully Assembled to DDX Valve w/Control Valve	6505040235	6505060235	Not Available
		Fully Assembled to DDX Valve w/o Control Valve	6505040236	6505060236	6505065236
		Segmentally Assembled (DDX Valve Sold Separately)	6503030071		
		Individual Parts (DDX Valve Sold Separately)	6503030070		
	250 psi (17,2 bar) Rated Solenoid Valve	Fully Assembled to DDX Valve w/Control Valve	6505040250	6505060250	Not Available
		Fully Assembled to DDX Valve w/o Control Valve	6505040251	6505060251	6505065241
		Segmentally Assembled (DDX Valve Sold Separately)	6503030073		
		Individual Parts (DDX Valve Sold Separately)	6503030072		
ULC Listed Pressure Switch	175 psi (12,1 bar) Rated Solenoid Valve	Fully Assembled to DDX Valve w/Control Valve	6505040265	6505060265	Not Available
		Fully Assembled to DDX Valve w/o Control Valve	6505040266	6505060266	6505065266
		Segmentally Assembled (DDX Valve Sold Separately)	6503030075		
		Individual Parts (DDX Valve Sold Separately)	6503030074		
	250 psi (17,2 bar) Rated Solenoid Valve	Fully Assembled to DDX Valve w/Control Valve	6505040270	6505060270	Not Available
		Fully Assembled to DDX Valve w/o Control Valve	6505040271	6505060271	6505065271
		Segmentally Assembled (DDX Valve Sold Separately)	6503030077		
		Individual Parts (DDX Valve Sold Separately)	6503030076		

Note: For metric installations, a 2” NPT x R2, ISO 7/1 x Close Nipple (Reliable P/N 98543401) is sold Separately as an adapter for the single drain outlet of the trims.

• **Additional Equipment (Refer to Fig. 7)**

Additional Equipment (Refer to Fig. 9)

Item No.	Component Part	Mfgr.	Description	Technical Bulletin
1	Water Supply Control Valve	Select	OS&Y, 4"(100mm), 6" (150mm) or 165mm	-
			Butterfly, 4"(100mm), 6" (150mm) or 165mm	-
	Tamper Switch (Optional) for OS&Y Valve	D	Model OS&Y2	System Sensor A05-0196
	(Optional) for Butterfly Valve		Model P1BV2	System Sensor A05-0197
2	Deluge Valve	B	Model DDX, 4"(100mm), 6" (150mm) or 165mm	Reliable 510 / 511
3	Double Interlock Trim Kit (Type F)	B	Refer to Parts List in this Bulletin	Reliable 729
4	Waterflow Alarm Pressure Switch	D	Model EPS10-2 (DPDT, UL, FM)	System Sensor A05-0176
			Model EPSA10-2 (DPDT, ULC)	
5	Mechanical Alarm (Optional)	B	Model C	Reliable 612 / 613
6	Releasing / Control Panel	C	Model PFC-4410-RC	Potter #5403550 Reliable 700/722
	Batteries		12 VDC, 12 AMP Hours (90 Hours Backup) FM	
			12 VDC, 7 AMP Hours (60 Hours Backup)	
	Optional Accessories		CA2Z (Class A Wiring Module for Initiating Circuits)	
			CAM (Class A Wiring Module for Indicating Circuits)	
			ARM-1 / ARM-2 (Auxiliary Relay Module)	
	RA-4410-RC (Remote Annunciator)			
7	Alarm Annunciator	A	Model SSM24-8 24 VDC / Polarized Bell	Reliable 700
			Model SSM24-10 24 VDC / Polarized Bell	
			Model MA24-D 24 VDC / Polarized Sounder	
			Model MASS24LO 24 VDC / Polarized Sounder Strobe	
8	Trouble Annunciator	A	Model SSM24-6 24 VDC / Polarized Bell	Reliable 700
			Model MA24-D 24 VDC / Polarized Sounder	
9	Manual Emergency Station (Elec.)	A	Model BNG-1 (SPDT) 1 & 2 Area Detection	Reliable 700
			Model BNG-1F (DPDT) Cross Zoned Detection	
10	Detection	Various	Smoke, Heat Detectors, etc.	Reliable 722
11	Sprinklers	B	Closed Type	Reliable 110, 117, 131, 136, etc.
12	Air Compressor	E	Tank Mounted	Gast H-10-0801
13	Pressure Maintenance Device	B	Model A-2	Reliable 250 / 251
14	* Accelerator Kit	B	Model B1	Reliable 323
15	Nitrogen Regulating Device	B	Regulator with Optional Low Air Pressure Switch	Reliable 253

* If the optional Model B1 Accelerator is used, a tank-mounted air compressor and an A-2 pressure maintenance device must be provided. Additionally the use of a tank-mounted air compressor helps to eliminate on/off compressor cycling that may occur as a result of small leakage in the air line between the pressure maintenance device and the check valve, (Item #63, Fig. 2) as well as due to ambient temperature changes in the system piping.

System Equipment Manufacturers

- (A) Notifier
- (B) The Reliable Automatic Sprinkler Co., Inc.
- (C) Potter Electric Signal Company
- (D) System Sensor
- (E) Gast Mfg, Inc.

TYPE F DOUBLE INTERLOCK PREACTION SYSTEM COMPONENTS

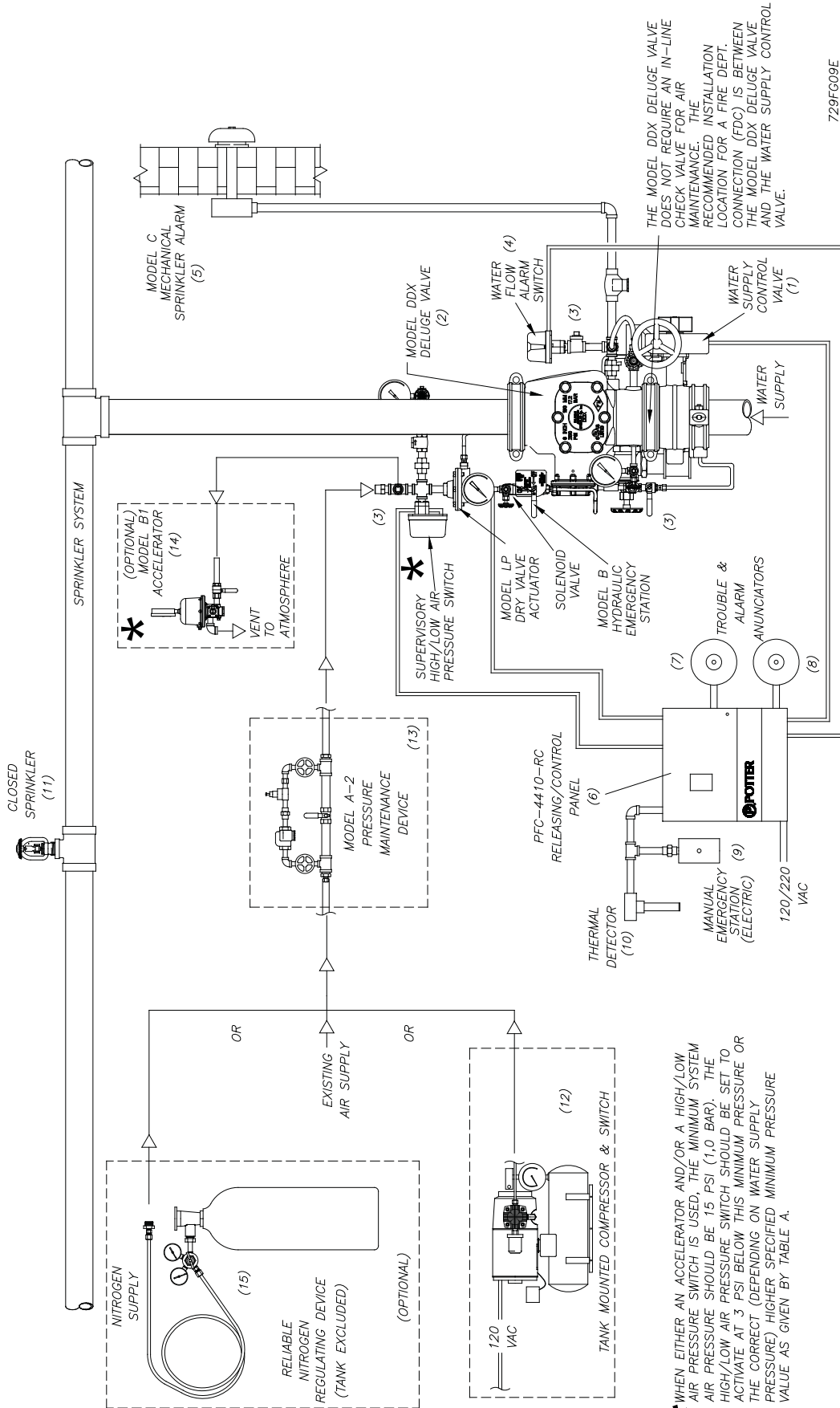

THE MODEL DDX DELUGE VALVE DOES NOT REQUIRE AN IN-LINE CHECK VALVE FOR AIR MAINTENANCE. THE RECOMMENDED INSTALLATION LOCATION FOR A FIRE DEPT. CONNECTION FOR A FIRE DEPT. THE MODEL DDX DELUGE VALVE AND THE WATER SUPPLY CONTROL VALVE.

729FG09E

Fig. 9

Installation Dimensions

Installation Dimensions in Inches (mm)

VALVE	A	B	C	*D	E	F	G	H	J	K	L	M	N	P	Q	R
4" (100mm)	5 ¹ / ₄ (133)	6 ³ / ₄ (171)	9 ¹ / ₂ (241)	14 (355)	26 ¹ / ₄ (667)	39 ³ / ₄ (1010)	31 ¹ / ₄ (794)	8 ¹ / ₂ (216)	12 (305)	5 ¹ / ₂ (140)	8 ¹ / ₂ (216)	13 ¹ / ₂ (343)	2 ¹ / ₂ (64)	6 ¹ / ₄ (159)	5 (127)	14 ⁵ / ₈ (371)
6" (150mm) & 165mm	6 ¹ / ₄ (159)	7 ³ / ₄ (197)	10 ¹ / ₂ (267)	16 (406)	27 ⁵ / ₈ (702)	41 ¹ / ₂ (1048)	32 ⁷ / ₈ (835)	8 ¹ / ₂ (216)	12 ¹ / ₂ (318)	5 ¹ / ₂ (140)	8 ¹ / ₂ (216)	13 ¹ / ₂ (343)	3 ¹ / ₄ (83)	8 ³ / ₄ (222)	5 (127)	14 ⁵ / ₈ (371)

* Total take out dimension for Fully Assembled to DDX Valve w/Control Valve Configurations:

4" - 20⁷/₁₆, 6" - 23³/₄", 165 mm - N/A.

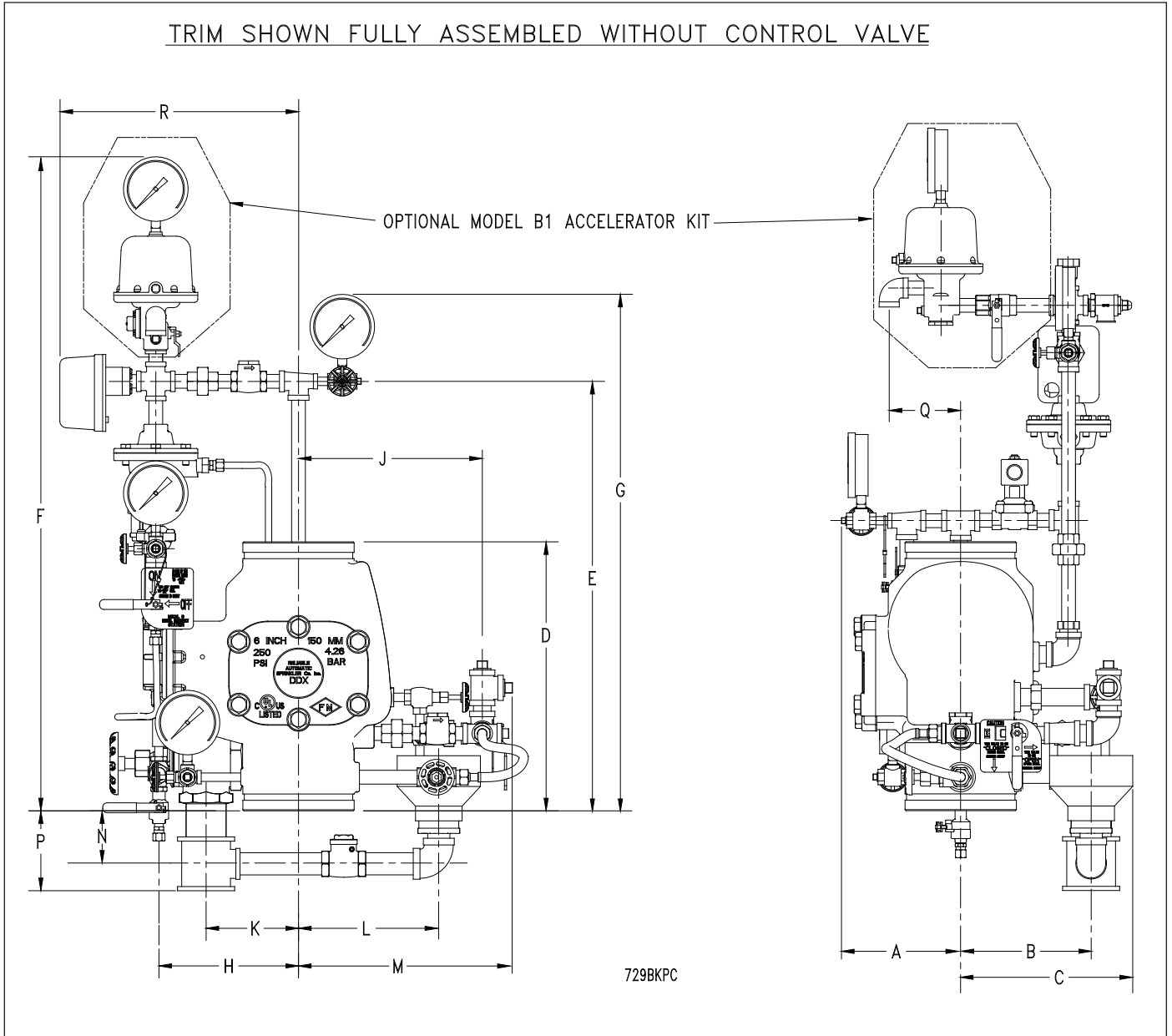

SOLENOID VALVE INSPECTIONS, TESTS AND MAINTENANCE

WARNING: THE OWNER IS RESPONSIBLE FOR MAINTAINING THE FIRE PROTECTION SYSTEM IN PROPER OPERATING CONDITION. ANY SYSTEM MAINTENANCE OR TESTING THAT INVOLVES PLACING A CONTROL VALVE OR DETECTION SYSTEM OUT OF SERVICE MAY ELIMINATE THE FIRE PROTECTION OF THAT SYSTEM. PRIOR TO PROCEEDING, NOTIFY ALL AUTHORITIES HAVING JURISDICTION. CONSIDERATION SHOULD BE GIVEN TO EMPLOYMENT OF A FIRE PATROL IN THE AFFECTED AREA.

WARNING: PRIOR TO OPERATING THE SOLENOID VALVE, BE SURE TO CLOSE THE SYSTEM CONTROL VALVE TO AVOID UNINTENTIONAL OPERATION OF THE DELUGE VALVE

1. Inspections: It is imperative that the system be inspected and tested in accordance with NFPA 25 on a regular basis. The frequency of the inspections may vary due to contaminated water supplies, corrosive water supplies, or corrosive atmospheres. In addition, the alarm devices, detection systems, or other connected trim may require a more frequent schedule. Refer to the system description and applicable codes for minimum requirements.
2. The valve must be inspected at least monthly for cracks, corrosion, leakage, etc., and cleaned, repaired, or replaced, or replaced as necessary.
3. If leakage is suspected through the solenoid valve, the valve diaphragms and seats should be inspected and if necessary, repaired or replaced.

WARNING: CLOSE SYSTEM CONTROL VALVE, TURN OFF POWER SUPPLY, AND DEPRESURIZE VALVE BEFORE DISASSEMBLING VALVE. IT IS NOT NECESSARY TO REMOVE THE VALVE FROM THE PIPE LINE TO MAKE INSPECTIONS.

4. When lubricating valve components, use high grade silicone grease (Dow Corning® 111 Compound Lubricant or equal).
5. When reassembling, tighten parts to torque values indicated in the manufacturer's maintenance instructions (packed with valve).
6. After maintenance is completed, operate the valve a few times to be sure of proper operation. A metallic "click" signifies the solenoid is operating.
7. All service must be performed by qualified personnel. Upon completion of inspections or replacement of the valve, the entire system must be checked for proper operation. See appropriate system description and testing instructions for additional information.

The equipment presented in this bulletin is to be installed in accordance with the latest published Standards of the National Fire Protection Association, Factory Mutual Research Corporation, or other similar organizations and also with the provisions of governmental codes or ordinances whenever applicable.

Products manufactured and distributed by Reliable have been protecting life and property for over 90 years, and are installed and serviced by the most highly qualified and reputable sprinkler contractors located throughout the United States, Canada and foreign countries.

Manufactured by

Reliable[®]

The Reliable Automatic Sprinkler Co., Inc.
(800) 431-1588 Sales Offices
(800) 848-6051 Sales Fax
(914) 829-2042 Corporate Offices
www.reliablesprinkler.com Internet Address



Revision lines indicate updated or new data.

EG. Printed in U.S.A. 09/11 P/N 9999970275