



**Model H PrePak  
Preaction System  
1½" (40mm)**

**Instructions for  
Installation, Operation,  
Care and Maintenance**

**Single Interlock  
Double Interlock**

**10 PSI (0,7 bar) Pneumatic Supervising Pressure**

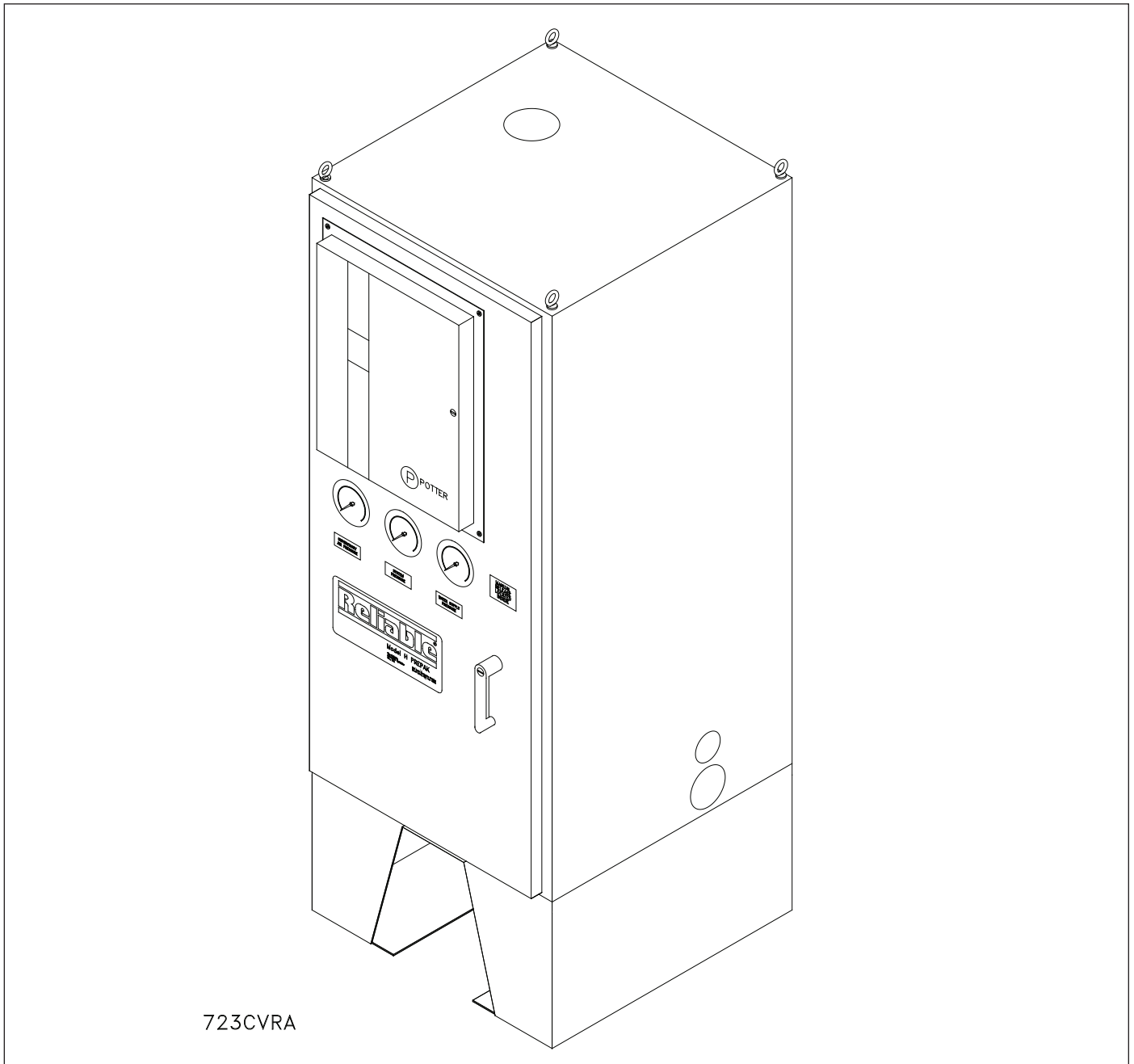

723CVRA

## General Description

The Reliable Model H 1½" (40mm) PrePaK is a completely self-contained, supervised preaction system that can be readily installed within a floor space of 4.5 square feet. Installation of the PrePaK (not including exterior devices, i.e., detectors and alarm bells) requires just three piping connections: a 1½" (40mm) supply line, a 1½" (40mm) system line, and a ¾" (20mm) drain line. Reference locations of these piping connections are shown in Figure 1. Also, two 120 VAC (or 220 VAC) electrical supply connections are required.

The Reliable Model H 1½" (40mm) PrePaK contains the following components within its 64" H x 24" W x 27" D (162.6cm H x 61cm W x 68.6cm D) gauge 12 steel enclosure:

- One Reliable Model H 1½" (40mm) Deluge Riser Assembly (See Reliable Bulletin 507).
- One Reliable Model A-2 Pressure Maintenance Device (See Reliable Bulletin 251).
- One Reliable Model G 2½" (65mm) Right-Check Valve™ w/ Preaction Trim Kit (See Reliable Bulletin 806).
- One Gast Model1 1HAB-11TM100X HP Tank-Mounted Air Compressor with 2 Gallon (7.6 liter) tank (See Reliable Bulletin 700).
- One Potter Model PFC-4410-RC Releasing Control Panel (See Potter Manual #5403550).
- All required fittings, gauges, electrical connectors, and electrical devices to utilize the system in single interlock, single interlock cross-zoned, double interlock, and double interlock cross-zoned applications.

The Reliable Model H utilizes the Potter Model PFC-4410-RC Releasing Control Panel. This fully programmable, microprocessor based releasing panel is Underwriters Laboratories, Inc. Listed and is in compliance with NFPA 13 and NFPA 72. Because the PFC-4410-RC is totally zone and output programmable, the Reliable Model H PrePaK can be utilized in four different preaction applications without having to rewire any of the factory installed devices. Once the previously described connections are completed, the 24 VDC detectors, output devices, and relay contacts may be connected to achieve the desired system implementation.

The Model H PrePaK can be used in both single and double interlock applications. Reliable Single and Double Interlock Preaction Systems are designed for water sensitive areas, which require protection from inadvertent water flow into the sprinkler system piping.

The major benefits of a single and/or double interlock preaction system, when compared with a wet pipe system, are as follows:

- A. A fire alarm sounds prior to the flow of water from a sprinkler, which may enable extinguishing the fire by handheld means before the operation of any sprinkler head occurs.
- B. An annunciator signals whenever the integrity of piping or sprinklers is accidentally or intentionally disturbed; however, no water flow or water damage will result at that time.
- C. Speedy detection and an early fire alarm are provided by fire detectors, without the delay associated with water delivery time in the event of a fire. Note that with a wet pipe system, the fire alarm is delayed until after water has begun flowing from an operated sprinkler head.

In single interlock applications, one electrical detector senses the presence of fire, thereby causing the electrical releasing control panel to activate fire alarm devices and latch the solenoid releasing valve in the open position. Note that arranging detectors in a cross-zoned pattern will require operation of two detectors before the solenoid

valve can open (**Note:** Cross-zoned detection systems are not permitted in New York City and are not Factory Mutual Approved). The solenoid valve, when closed, is preserving supply water pressure in the inlet of the Reliable Model H Deluge Riser Assembly. Actuating the solenoid valve releases that water pressure, allowing water flow into the sprinkler system in readiness for the subsequent operation of a sprinkler.

To fully operate a single interlock system with cross-zoned detection, two separate electrical detection systems must activate and a sprinkler must open. During the early stages of a fire, smoke or heat activates the first detector, which causes the control panel to produce a local alarm and an alarm at the main fire alarm panel. Electrical relays inside the releasing control panel can be used to shut down air moving equipment or activate security doors and other electrical devices when the panel goes into this first alarm condition. Subsequent activation of a second, nearby or adjacent detector, on a separate detection system, will cause the panel to energize the solenoid valve open and release water into the sprinkler piping. Water flowing into the sprinkler piping will simultaneously produce water pressure that causes the transfer of contacts in the pressure switch mounted in the riser assembly, thereby activating a water flow alarm device. The flow of water into the sprinkler piping effectively converts the dry system into a wet pipe system. In the event the fire subsequently produces sufficient heat to operate a sprinkler head, water will flow from that sprinkler, controlling the fire.

To flow water into a double interlock preaction system, two events must take place. A fire detection device must operate, and a pressure switch must be operated by the loss of system pressure (sprinkler operation). These two signals, both an electric signal and a pneumatic signal, must coexist at the releasing control panel, which only then will energize the solenoid releasing valve, causing water flow into the system and out of the open sprinkler(s).

In the event that the system piping is ruptured or a sprinkler head is accidentally opened, the system pressure switch will operate and an alarm will sound. The riser assembly, however, will not release water since the solenoid valve remains closed due to only one input into the control panel.

When using the Reliable Model H PrePaK in either single or double interlock applications, the sprinkler system is pressurized (supervised) with air provided by the HP tank-mounted air compressor and is monitored by the system pressure switch.

A hydraulic manual emergency releasing station is standard equipment in the Model H PrePaK. It is identified by a nameplate attached above the releasing valve.

Preaction trim provides a by-pass drain line and the air supply required to supervise the preaction system at 10 psi (0,7 bar). This trim includes a UL Listed Reliable Model G Right-Check Valve installed with rigid grooved pipe couplings.

## Approvals

The Reliable Model H 1½" (40mm) PrePaK Preaction System is Underwriters Laboratories Inc. (UL) Listed and UL Certified for Canada\*, as an assembled unit, in the "Special System Water Control Valves Assembled Units" category (VKYL). New York City Approved, MEA 258-93-E, when installed in accordance with the following guidelines and limitations:

For Single Interlock Preaction Systems:

1. Cross-zoning of preaction system detectors is prohibited, except where used as a secondary system to a gaseous suppression system.

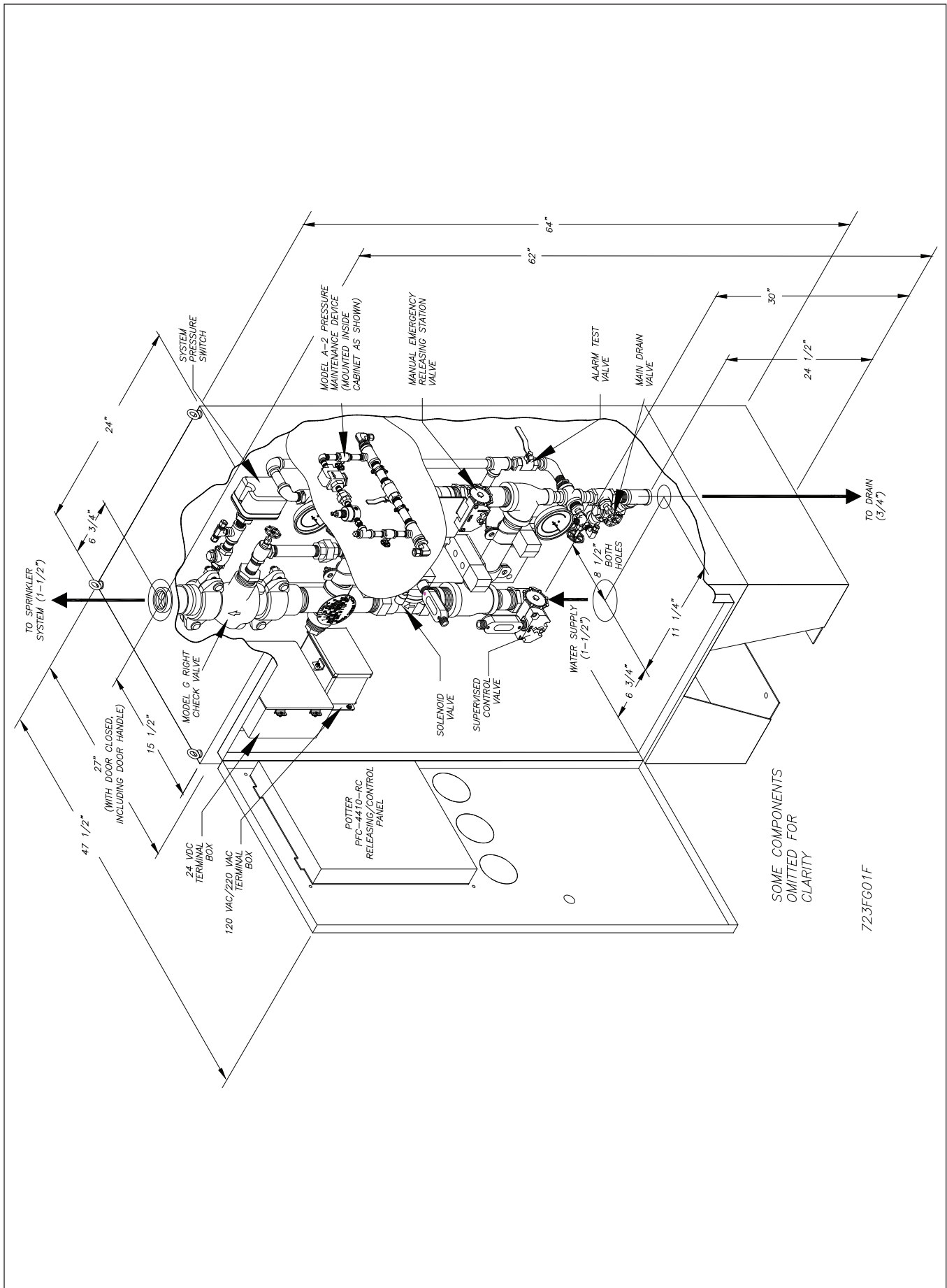

Figure 1 — Installation Dimension

2. A minimum of two (2) detectors must be installed for each zone in the protected area.
3. Only Class A method of wiring detectors shall be used.

For Double-Interlock Preaction Systems:

1. Are required for freezer or refrigerated room applications, or where conditions will allow water to freeze in the system piping prior to sprinkler actuation.
2. Cross-zoning of preaction system detectors is prohibited, except where used as a secondary system to a gaseous suppression system.
3. A minimum of two (2) detectors must be installed for each zone in the protected area.
4. Only Class A method of wiring detectors shall be used.
  - \* Electrical devices and control panel must be specified to meet Canadian requirements. This option is available.

**Note:** Although PrePak units are UL Listed, custom built units are sometimes supplied upon request. The components within these special units maintain their individual Listings, whereas the assembled units do not.

PrePak units are also available without their door-mounted Potter PFC-4410-RC Releasing/Control Panel and Air Compressor. These units will still retain their Listings, however the installing contractor should make sure that any remote controlled Releasing/Control Panels used with these units are Listed and programmed to handle the required sequence of operation necessary to operate the automatic sprinkler system.

Any unauthorized modification or addition made on-site to a factory built Listed unit will void the Listing. Such modifications or additions may void the units warranty as well. Consult Reliable's Technical Services Department before proceeding with such modifications or additions.

## Technical Data

The Reliable Model H 1½" (40mm) PrePaK is rated for a minimum supply pressure of 20 psi (1,4 bar) and a maximum supply pressure of 175 psi (12 bar).

Friction loss, expressed in equivalent length of Sch. 40 pipe and based on Hazen-Williams formula with C=120 and a flowing velocity of 15 ft/s (4.6m/s), is 36 ft. (11m). This friction loss value includes all components of the Model H Riser Assembly and Model G Right-Check™ Check Valve.

Shipping Weight: 460 lbs. (209 kg)  
 Enclosure Dimensions: 64" H x 24" W x 27" D  
 (162.6cm H x 61cm W x 68.6cm D)

The following is a list of Technical Data Bulletins which describe the valves and devices which in this system:

Deluge Valve	507
Right-Check™ Riser Valve	806
Low Air Pressure Switch	A05-0176 (System Sensor)
Hydraulic Emergency Station	506
Mechanical Sprinkler	612/613
Solenoid Valve	718
Water Flow Pressure Alarm	A05-0176 (System Sensor)
Pressure Maintenance Device	252
Releasing Control Panel	(Potter Manual #5403550)
Detectors	722
Fire Alarm Devices	700

## System Design Considerations

The automatic sprinklers, releasing devices, fire detection devices, manual pull stations, and signaling devices which are utilized with the Reliable Model H 1½" (40mm) PrePaK must be UL and/or ULC Listed, as applicable.

The steel enclosure and all interconnecting piping must be located in a readily visible and accessible location and in an area that can be maintained at a minimum temperature of 40°F (4°C). **Note:** Heat tracing is not permitted.

The solenoid valve is operated and supervised by the Potter Electric Releasing Control Panel. Details on the electrical connections of this system to a Potter Model PFC-4410-RC Releasing Control Panel can be found in Potter Manual #5403550, Installation, Operation and Instruction of PFC-4410 Fire Alarm/Releasing Panel (this manual is included with other pertinent manuals and shipped inside the enclosure). This panel is fully zone and output programmable and may be adapted to several applications. The following table provides a quick reference to various programs (found in this Bulletin and Potter Manual #5403550) that may be utilized with the Model H PrePaK:

Desired Application <sup>(1)</sup>	Description	Program No.
Single Interlock	Single Hazard, 2 Alarm Zones with 1 Waterflow Zone and 2 Supervisory Zones	Potter Program #6 Custom Program #1 (NYC)
Single Interlock, Cross-Zoned	Single Hazard, Cross-Zoned, 2 Alarm Zones with 1 Waterflow Zone and 2 Supervisory Zones	Potter Program #7 <sup>(2)</sup>
Double Interlock, 2 Independent Events	Single Hazard, 2 Alarm Zones with 1 Waterflow Zone and 1 Supervisory Zone	Potter Program #9
Double Interlock, Cross-Zoned 3 Independent Events	Single Hazard, Cross-Zoned, 3 Alarm Zones with 1 Waterflow and 1 Supervisory Zone	Potter Program #10

<sup>(1)</sup> Refer to Potter Manual #5403550, included with the PrePaK, for other programming options.

<sup>(2)</sup> Factory Program Setting.

## System Supervising Pressure Requirements

In accordance with NFPA 13 (1996), when using the Reliable Model H 1½" (40mm) PrePaK in double interlock applications, a minimum of 7 psi (0,5 bar) pneumatic pressure is required to supervise the sprinkler system. When initially filling the system with air, the enclosure door should remain open to provide maximum air flow to the compressor. The Model A-2 Pressure Maintenance Device, supplied with the system, is factory set to maintain system pneumatic pressure at approximately 10 psi (0,7 bar).

Readjusting system pressure to approximately 10 psi (0,7 bar) is accomplished by referring to Reliable Bulletin 251 for adjustment procedure. The low pneumatic pressure supervisory switch is factory set to operate between 8 and 4 psi (0,6 bar to 0,3 bar) with decreasing pressure. Adjustment, if required, should be made according to Bulletin A05-0176 included with the switch.

## System Electrical Requirements

All releasing, alarm, and detection devices in the Reliable Model H 1½" (40mm) PrePaK are supervised by a Potter Model PFC-4410-RC Releasing Control Panel. To utilize the door of the steel enclosure as a mount for the releasing control panel, all of the terminals are translated to two water-tight terminal boxes mounted on the interior wall of the enclosure. **Note:** The EOL resistors have also been relocated. It is from these terminal boxes that all field wiring is connect-

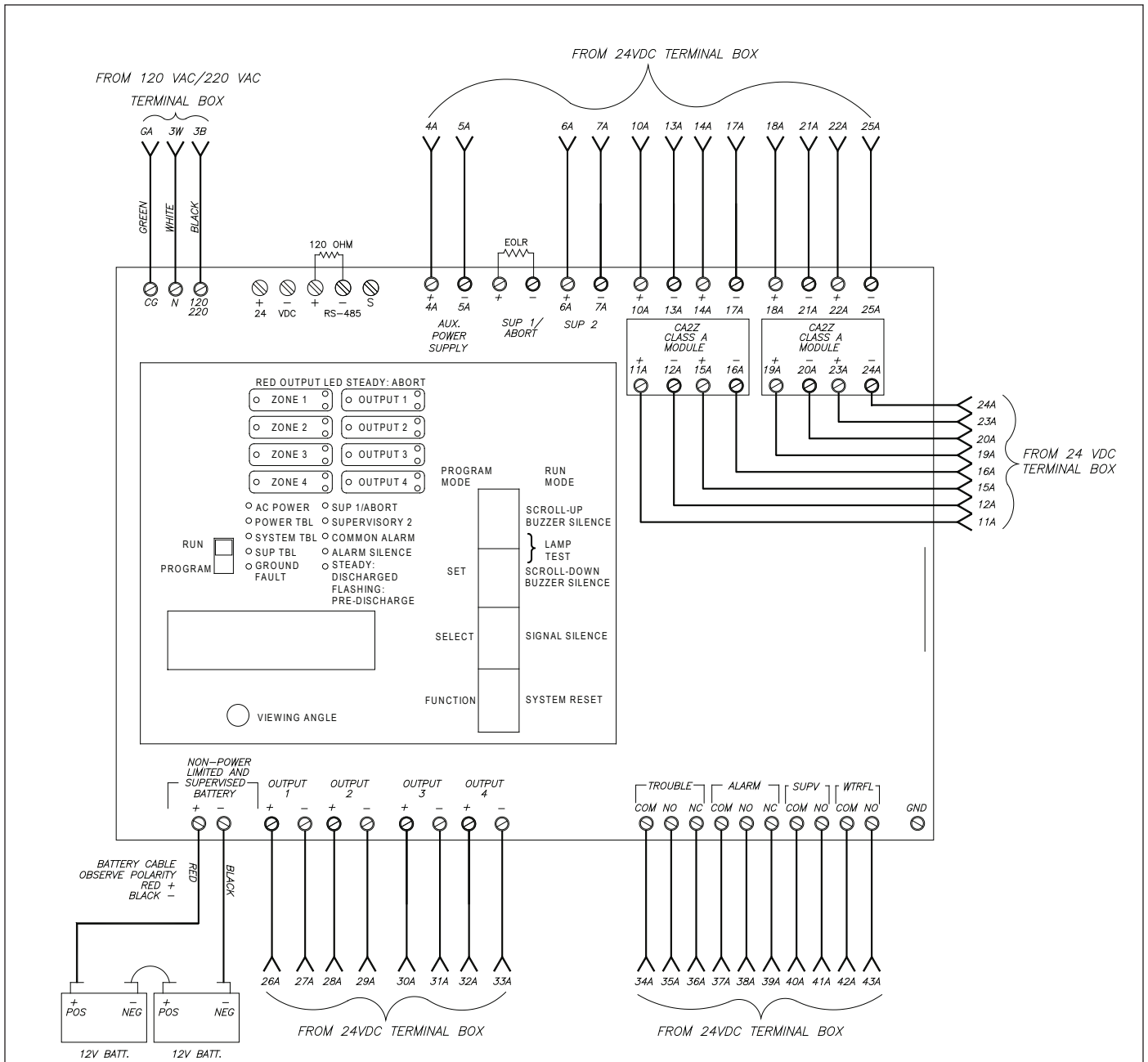

- NOTES:
1. Connect only UL listed 24VDC devices to outputs.
  2. Connect EOL diode assy. IN SERIES with solenoid on release circuit.
  3. Leave EOLR (provided) on all unused circuits.
  4. Polarity marked on outputs is for a normal, non-activated condition.
  5. Polarity reverses when output is activated.
  6. Max. current per output is 1 amp.
  7. Max. current for all outputs combined is 2.5 amps.
  8. All initiating and release circuits are supervised and power limited.

POTTER PFC-4410-RC RELEASING CONTROL PANEL

723FG02D

Figure 2—Wiring Diagram

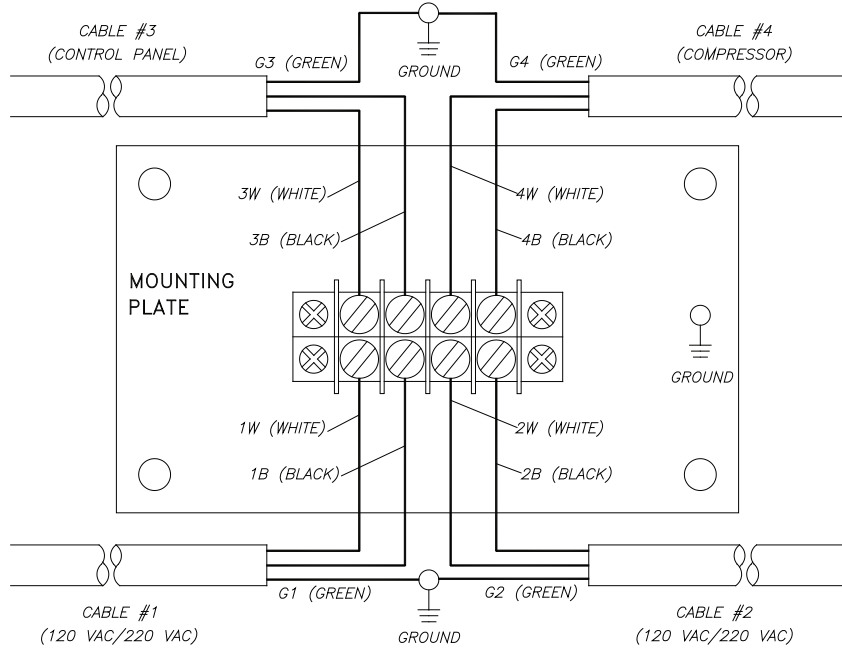

120 VAC/220 VAC TERMINAL BOX (FACTORY CONNECTIONS)

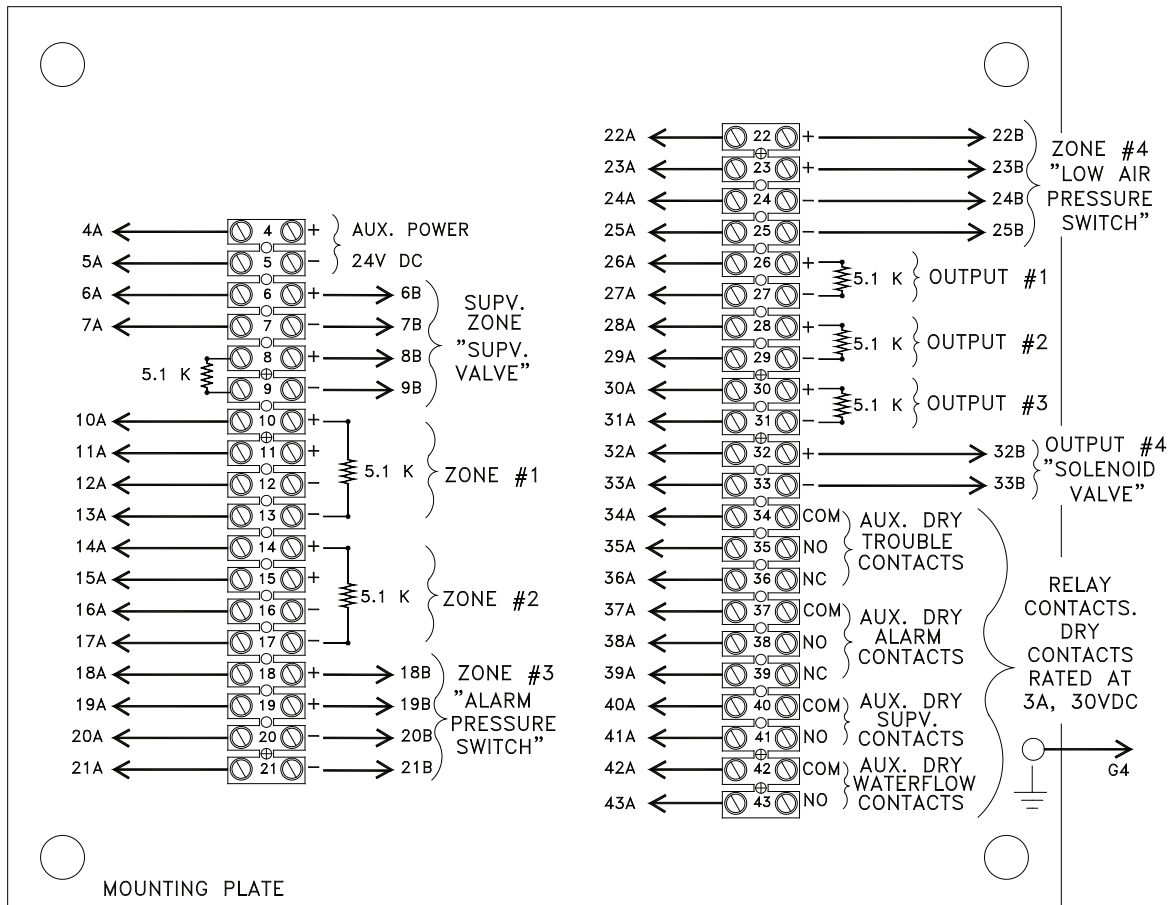

24 VDC TERMINAL BOX (FACTORY CONNECTIONS)

723FG03D

Figure 3—Wiring Diagram

ed. One terminal box contains all of the 24 VDC connections and one contains the 120 VAC (or 220 VAC) connections. The diagrams illustrating this translation of terminals are shown in Figures 2 and 3. The Reliable Model H PrePaK is delivered with five factory-installed electrical devices. They consist of the following:

1. A low air, supervisory pressure switch, which is used to monitor sprinkler piping.
2. A waterflow indicating pressure switch.
3. A releasing solenoid valve.
4. A 1/6 HP tank-mounted air compressor.
5. A supervised, slow-close control valve.

The factory electrical connections for these devices are illustrated in Figure 4. For information on how to install fire detection devices to Initiating Zones 1 and 2, refer to Figures 5 or 6. For information on how to install output devices, i.e., alarm bells or trouble annunciators, refer to Figure 7. The power supply, standby emergency power supply, battery charger and rectifier circuitry are all contained within the PFC-4410-RC Panel. Batteries that provide 90 hours of standby power are provided with the panel. For additional information and detailed wiring diagrams, refer to Potter Manual #5403550, Installation, Operation and Instruction of PFC-4410-RC Releasing Control Panel.

**Caution:** Repairs or disassembly of the solenoid valve should only be done by a trained technician. An improperly repaired or partially assembled solenoid valve could result in failure of the valve to operate.

### System Operation (Single Interlock)

To activate the Reliable Model H 1½" (40mm) PrePaK in a single interlock application, an electrical detector (two detectors with cross-zoned detection) must activate to fill the system with water. Subsequently, a sprinkler head must open to discharge water on the fire. When a fire is detected, the releasing control panel energizes the solenoid valve open and water flows from the supply through the PrePaK to the system and to the waterflow indicating pressure switch. The valve maintains its open position until the solenoid is de-energized.

**CAUTION:** THE SOLENOID VALVE MUST BE MAINTAINED OPEN TO PREVENT AUTOMATIC CLOSING OF THE MODEL H DELUGE RISER ASSEMBLY. THE POTTER MODEL PFC-4410-RC RELEASING CONTROL PANEL HAS A LATCHING FEATURE FOR THIS PURPOSE.

After system shutdown and draining, the Model H Riser Assembly is easily reset without special tools. Restore detection devices by resetting or replacing any operated device. Once detection devices are restored, reset the releasing control panel (Potter Manual #5403550) and the supply pressure (see Bulletin 507, System Operation).

### System Operation (Double Interlock)

To activate the Reliable Model H 1½" (40mm) PrePaK in a double interlock application, two independent events must coexist before water flow will occur. A fire detection device must operate and the system pressure switch must actuate by reducing the system supervising air pressure (as a result of sprinkler operation). Operation of either one of these items will only cause an alarm to annunciate, and will not fill the sprinkler system piping with water. With coexisting initiating signals, one electric and one pneumatic, the control panel will now energize the solenoid valve to release water through the

PrePaK into the system piping and out the open sprinkler for complete operation of the system.

When the releasing control panel energizes the solenoid valve open, water flows from the supply through the riser into the system and to the waterflow indicating pressure switch. The valve maintains its open position until the solenoid is de-energized.

**CAUTION:** THE SOLENOID VALVE MUST BE MAINTAINED OPEN TO PREVENT AUTOMATIC CLOSING OF THE MODEL H DELUGE RISER ASSEMBLY. THE POTTER MODEL PFC-4410-RC RELEASING CONTROL PANEL HAS A LATCHING FEATURE FOR THIS PURPOSE.

After system shutdown and draining, the Model H Riser Assembly is easily reset without special tools. Restore detection devices by resetting or replacing any operated device. Once detection devices are restored, reset the releasing control panel (Potter Manual #5403550) and the supply pressure (see Bulletin 507, System Operation).

### Maintenance

The Reliable Model H 1½" (40mm) PrePaK and associated equipment shall periodically be given a thorough inspection and test. NFPA 25, Inspection, Testing and Maintenance of Water Based Fire Protection Systems, provides minimum maintenance requirements. Systems should be tested, operated, cleaned and inspected at least annually, and parts replaced as required. Periodically, open the bleeder valve on the compressor tank to drain any condensate accumulation. Refer to Bulletin 507 for information regarding maintenance of the solenoid valve and the manual emergency station valve. Bulletin 251 provides information on the Model A-2 Pressure Maintenance Device. Bulletin 806 describes the Model G Right-Check™ Valve. Potter Manual #5403550 describes the PFC-4410-RC Releasing Control Panel.

### Resetting Single Interlock Systems

Refer to Figure 1.

1. Close the supervised valve controlling water supply to the Model H Riser Assembly and shut off the system air supply at the Model A-2 Device.
2. Open all drain valves and the manual emergency station valve to drain the system through the riser assembly.
3. Open any low point drain valves and vents throughout the system, closing all drain valves and vents when draining of water has stopped.
4. Inspect and replace any portion of the sprinkler system and detection system exposed to fire conditions. Reset detectors and PFC-4410-RC Releasing Control Panel. The PFC-4410-RC is reset by pushing the "System Reset" button. This action will also close (reset) the solenoid valve.
5. Reset the Model H Riser Assembly in accordance with Bulletin 507, Model H Deluge Riser Assembly Instructions for Installation, Operation, Care and Maintenance.
6. Restore the system supervising pressure to approximately 10 psi (0,7 bar) by opening the valves on the Model A-2 Pressure Maintenance Device (refer to Bulletin 251) and adjusting the regulator, as required.
7. Verify that the supervised control valve is open, and proper monitoring has been restored. Also verify there is no leakage from the automatic drain valve, thereby confirming that supply water is not leaking into the system.

## Resetting Double Interlock Systems

Refer to Figure 1.

1. Close the supervised valve controlling water supply to the Model H Riser Assembly and shut off the system's air supply at the Model A-2 Device.
2. Open all drain valves and the manual emergency station valve to drain the system.
3. Open all the drain valves and vents at low points throughout the system, closing them when flow of water to drain has stopped.
4. Inspect and replace any portion of the sprinkler system and detection system exposed to fire conditions. Reset detectors.  
**Note:** It is not possible to reset the PFC-4410-RC panel until Step "6", which resets the system pressure switch, has been completed.
5. Restore the system supervising pressure to approximately 10 psi (0,7 bar) by opening valves on the Model A-2 Pressure Maintenance Device (refer to Bulletin 251) and adjusting the regulator, as required.
6. Verify that the bypass drain valve is closed to prevent the loss of pneumatic supervising pressure out of the automatic drain valve. When the supervising pressure has reached the 10 psi (0,7 bar) setting, the low air pressure switch will automatically reset (contacts now open).
7. With the low air pressure switch reset (Step "6") and all detectors replaced or reset (Step "4"), the PFC-4410-RC Releasing Control Panel can be reset. Pushing the "System Reset" button on the panel will simultaneously restore the solenoid valve to the closed condition.
8. Restore water supply to the Model H Riser Assembly in accordance with Bulletin 507, Model H Deluge Riser Assembly Instructions for Installation, Operation, Care, and Maintenance.

## Inspection and Testing of Single Interlock

Refer to Figure 1.

1. Water supply - be sure the supervised valve controlling water supply to the Model H Riser Assembly is open fully and properly supervised.
2. Other trimming valves - check that all pressure gauge valves are open, and that the Model A-2 Pressure Maintenance Device  $\frac{3}{4}$ " NPT fill valve is closed. The two  $\frac{1}{4}$ " NPT bypass line valves must be fully open.
3. Check that system supervising pressure is approximately 10 psi (0,7 bar).
4. Operation test - for detection only, operate by actuation of a keyed manual (electrical) emergency station (refer to Figure 5 for wiring instructions). Double interlock systems also require the supervisory pressure to be discharged, through the inspectors test station or other venting means, below 4 psi (0,3 bar) before total system operation will occur.

**Note:** Total system operation testing will cause water flow through the Model H Riser Assembly and into the system. Where difficulty in performance is experienced, contact Reliable Technical Services before any field adjustment is to be made.

## Testing Detection System Without Causing Water Flow (Single Interlock)

Refer to Figure 1.

1. Close the supervised valve controlling water supply to the Model H Riser Assembly, and note the water pressure gauge reading. Also, shut off the system air at the Model A-2 Device.
2. Operate the detection system - operate a cross-zoned releasing control panel by operating two detectors.
3. Operation of the detection system must result in a sudden drop of water pressure as the solenoid valve opens. When the water pressure gauge drops to zero, open main drain valve, bypass drain valve and manual emergency station valve until all water above the supervised control valve drains away.
4. Reset detection system - reverse operations performed in Step "2" above. All detection devices must be reset before the PFC-4410-RC Releasing Control Panel can be reset. The solenoid valve closes when the releasing panel is reset. Close the bypass drain valve and manual emergency station valve.
5. Slightly open the supervised valve controlling water supply to the Model H Riser Assembly, closing main drain valve when water flows steadily. Open slowly, but fully, the supervised control valve and monitor it properly.
6. It is necessary to shut down the supervisory pressure supply (ref. Step "1") during testing; otherwise, low pressure annunciation can occur when the drain valves are opened in Step "3". Restore the supervisory pressure to 10 psi (0,7 bar) at this time.

## Testing Detection System Without Causing Water Flow (Double Interlock)

Refer to Figure 1.

1. Close the supervised valve controlling water supply to the Model H Riser Assembly, and note the lower water pressure gauge reading.
2. Operate a double interlock system by operating one detector and also venting the supervising pressure, through the inspectors test station, below 4 psi (0,3 bar), to operate the low air pressure switch.
3. Operation of a detector and the system pressure switch must result in a sudden drop of water pressure as the solenoid valve opens. When the water pressure gauge drops to zero, open the main drain and bypass drain valves until all water above the supervised control valve drains away.
4. Reset system by following the operation described previously in Steps "5" through "7" of the section named "Resetting Double Interlock Systems." All detection devices must be reset before the PFC-4410-RC Releasing Control Panel can be reset.
5. Open slightly the supervised valve controlling water supply to the Model H Riser Assembly, closing the main drain valve after water flows steadily through it. Open slowly, but fully, the control valve and supervise it properly. Verify there is adequate water supply pressure and proper pneumatic supervisory pressure on the appropriate gauges. There should be no pressure reading on the water gauge directly above the manual emergency releasing station when the system is properly reset.

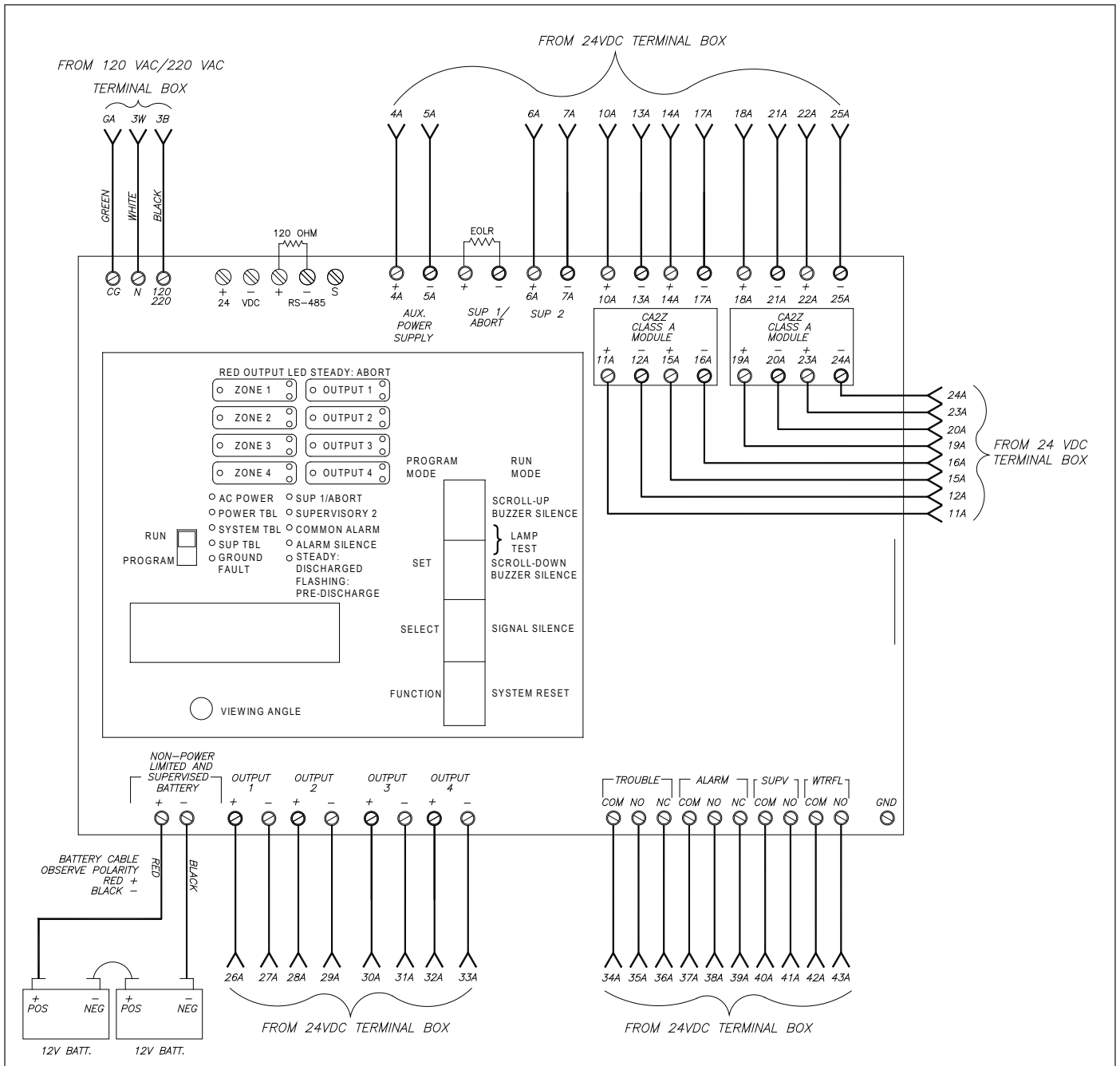

- NOTES:
1. Connect only UL listed 24VDC devices to outputs.
  2. Connect EOL diode assy. IN SERIES with solenoid on release circuit.
  3. Leave EOLR (provided) on all unused circuits.
  4. Polarity marked on outputs is for a normal, non-activated condition.
  5. Polarity reverses when output is activated.
  6. Max. current per output is 1 amp.
  7. Max. current for all outputs combined is 2.5 amps.
  8. All initiating and release circuits are supervised and power limited.

POTTER PFC-4410-RC RELEASING CONTROL PANEL

723FG02D

Figure 4—Wiring Diagram

SMOKE DETECTOR:  
 PHOTOELECTRIC, MODEL PSD 7125, BASE MODEL 70-201000-001  
 IONIZATION, MODEL CPD 7021, BASE MODEL 70-201000-001  
 U.L. LISTED

THERMAL DETECTOR:  
 INTERIOR, MODELS 302 AND 302H  
 WEATHER PROOF, MODEL 302AW  
 U.L. LISTED, F.M. APPROVED

THERMAL  
 DETECTOR  
 MODEL  
 302AW

THERMAL  
 DETECTOR  
 MODEL  
 302,302H

MANUAL  
 EMERGENCY  
 STATION  
 MODEL  
 BNG-1

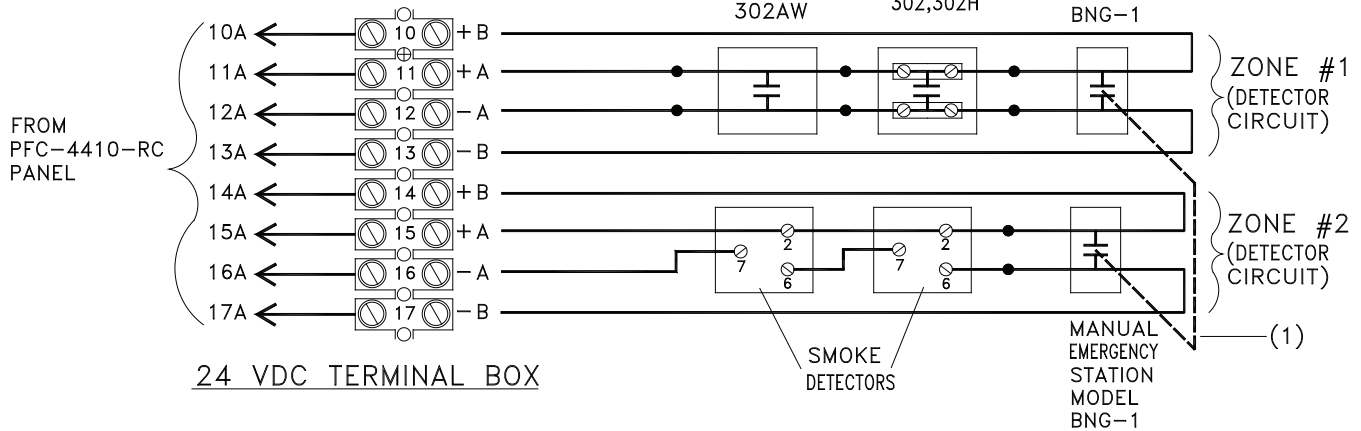

### CLASS 'A' DETECTOR CIRCUIT WIRING

(1)  
 USE MANUAL EMERGENCY STATION MODEL BNG-1F WHEN USING EITHER CROSS-ZONED DETECTION\* OR THE DOUBLE INTERLOCK PREACTION SYSTEM OPTION. THIS STATION ACTIVATES BOTH DETECTION CIRCUITS SIMULTANEOUSLY.

\*NOT PERMITTED IN NEW YORK CITY.  
 \*NOT FM APPROVED.

723FG05D

Figure 5 — Wiring Diagram

SMOKE DETECTOR:  
 PHOTOELECTRIC, MODEL PSD 7125, BASE MODEL 70-201000-001  
 IONIZATION, MODEL CPD 7021, BASE MODEL 70-201000-001  
 U.L. LISTED

THERMAL DETECTOR:  
 INTERIOR, MODELS 302 AND 302H  
 WEATHER PROOF, MODEL 302AW  
 U.L. LISTED, F.M. APPROVED

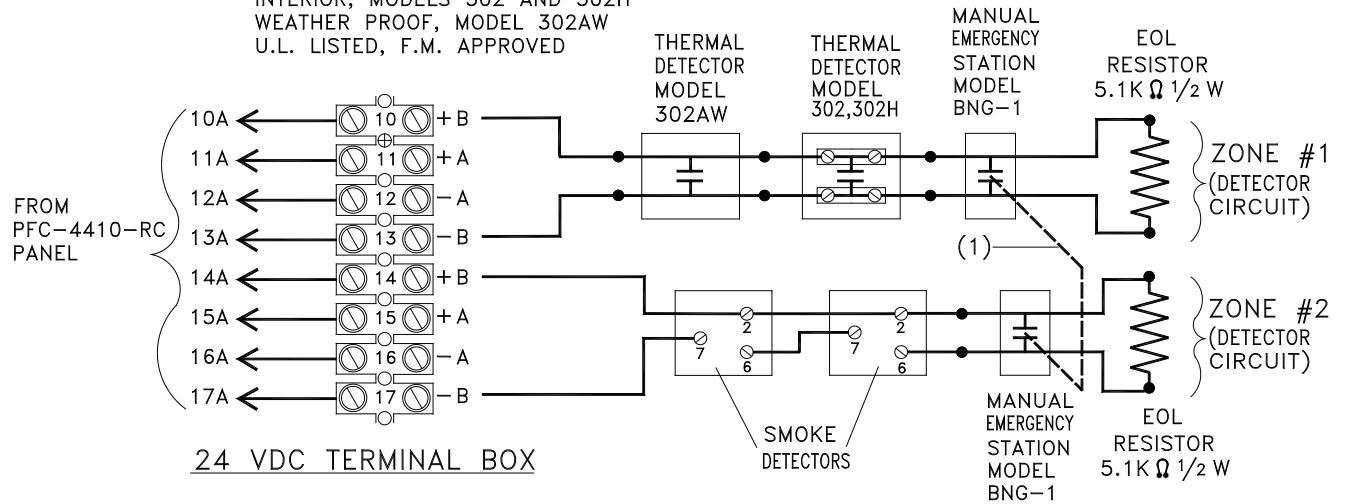

CLASS 'B' DETECTOR CIRCUIT WIRING

(1) USE MANUAL EMERGENCY STATION MODEL BNG-1F WHEN USING EITHER CROSS-ZONED DETECTION\* OR THE DOUBLE INTERLOCK PREACTION SYSTEM OPTION. THIS STATION ACTIVATES BOTH DETECTION CIRCUITS SIMULTANEOUSLY.

\*NOT PERMITTED IN NEW YORK CITY.  
 \*NOT FM APPROVED.

723FG06D

Figure 6—Wiring Diagram

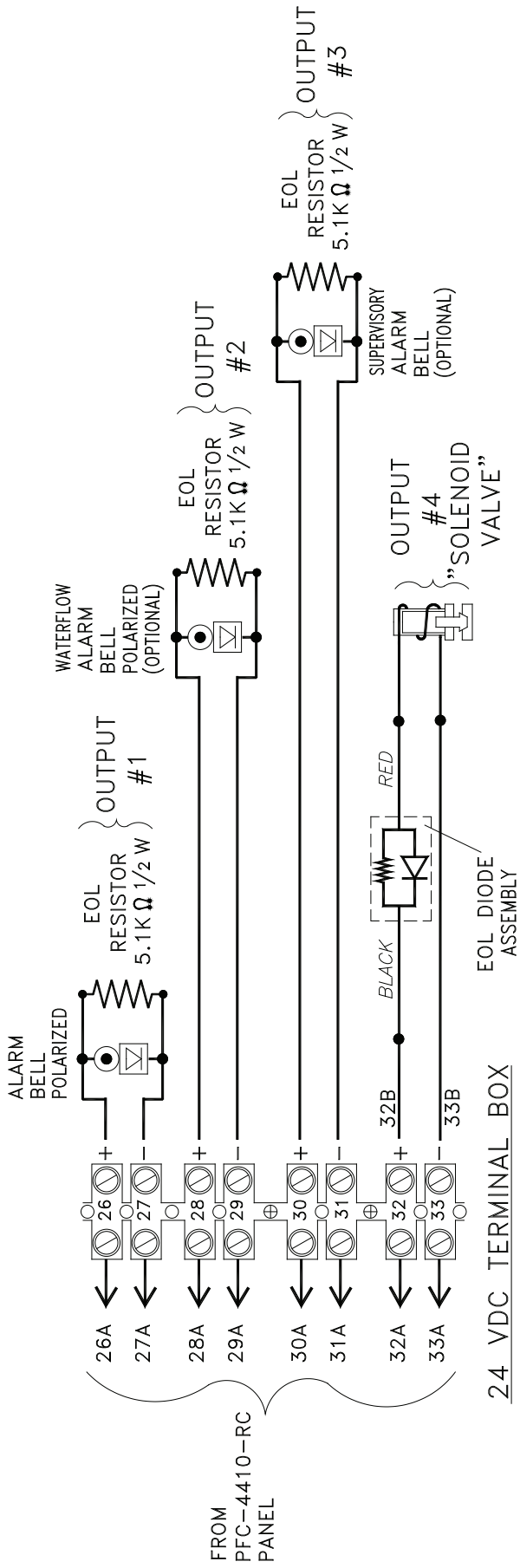

OUTPUT DEVICE CIRCUIT WIRING

723FG07C

Figure 7 — Wiring Diagram

## **Potter Program #6**

### **Single Interlock Programming Instructions (Single Hazard, 2 Alarm Zones, 1 Waterflow Zone, and 2 Supervisory Zones)**

1. Apply power to panel.
2. Slide the program switch down.
3. Press the FUNCTION button until the display reads "PASSWORD = 000."
4. To enter a password, press the SELECT button until the proper number is displayed above the "^" symbol; then press the SET button to move to the next digit. After entering the third number the display will change. (All panels are shipped with a "000" password).
5. Press the FUNCTION button until the display reads "PROGRAM ##" (the second "#" character refers to the current program number between "0" and "24").
6. Press the SELECT button until the display reads "PROGRAM #6."
7. Press the SET button.
8. The panel is completely programmed except for the custom banner and zone messages. Slide the program switch back up.

## **POTTER PROGRAM #6**

OUTPUTS	ZONES				
	*Supervisory 2	#1 Conventional	#2 Manual Release	#3 Waterflow	#4 Low Air Supervisory
#1 ALARM		X	X		
#2 WATERFLOW				X	
#3 SUPERVISORY	X				X
#4 RELEASE		X	X		

INPUT: 1 conventional zone, 1 manual release zone, 1 waterflow zone, 1 low air zone, 1 supervisory zone.  
 OUTPUT: 1 general alarm bell, 1 waterflow bell, 1 supervisory bell, 1 solenoid release circuit.  
 OPERATION: Activation of either the conventional zone or the manual release will operate the solenoid release circuit and the general alarm bell.  
 Activation of the waterflow zone will operate the waterflow bell.  
 Activation of either the low air zone or the supervisory zone will operate the supervisory bell.  
 When either Zone #1 or #2 is in alarm, Output #1 (general alarm) and Output #4 (solenoid release) will operate.  
 When Zone #3 is in alarm, Output #2 (waterflow bell) will operate.  
 When either Zone #4 or the supervisory zone is activated, Output #3 (supervisory bell) will operate.

**\* The Butterfly valve in the PrePaK assembly is connected to Supervisory 2 input of the Potter PFC-4410RC Releasing/Control panel.**

**Refer to the "Installation, Operation and Instruction Manual" for the PFC-4410-RC Releasing Control Panel for Additional Information.**

# POTTER PROGRAM #6 WIRING DIAGRAM

## SINGLE HAZARD, 2 ALARM ZONES 1 WATERFLOW ZONE AND 2 SUPERVISORY ZONES

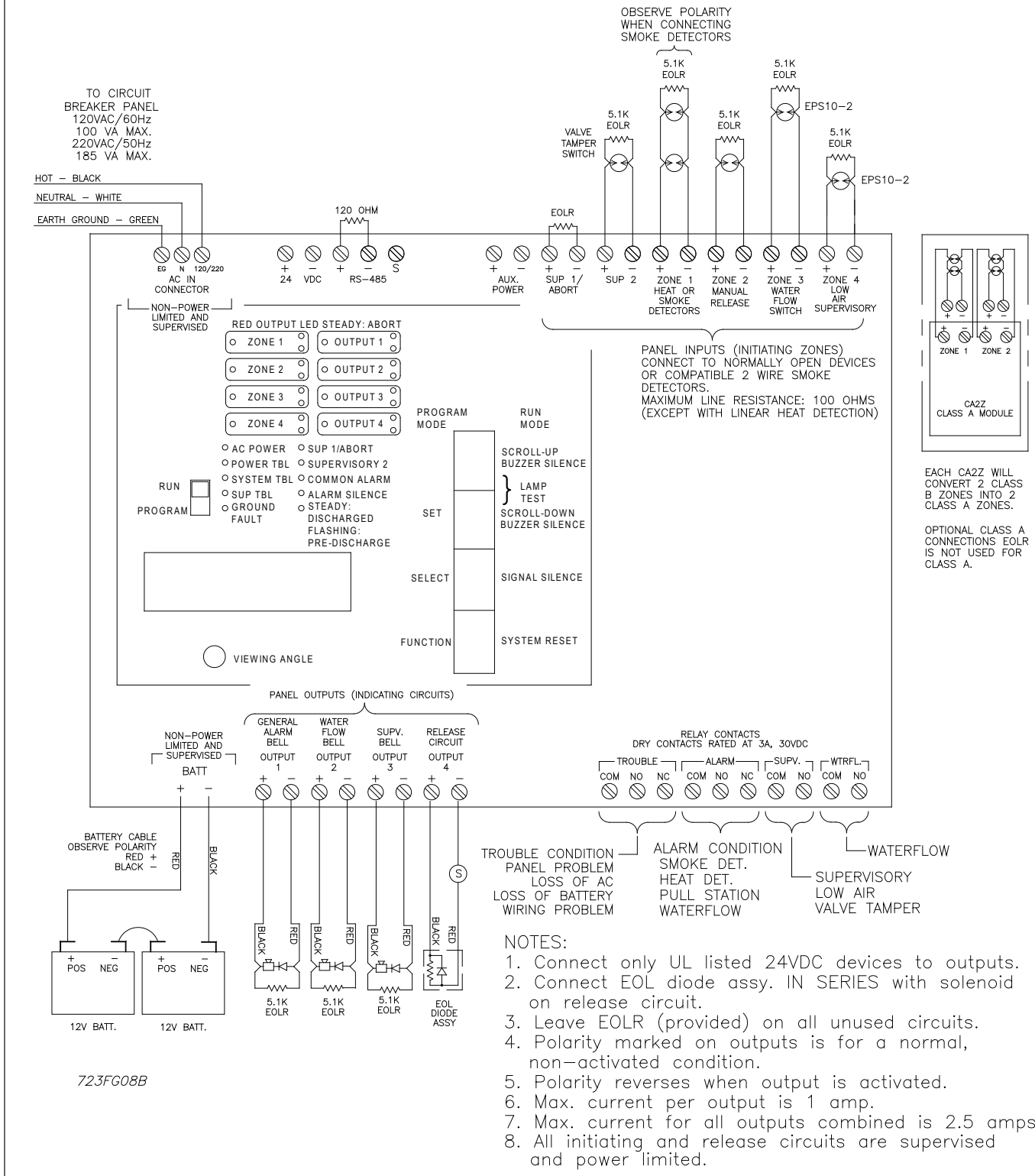

Figure 8—Wiring Diagram

## **Potter Program #7**

### **Single Interlock Programing Instructions (Single Hazard - Cross-Zoned, 2 Alarm Zones, 1 Waterflow Zone and 2 Supervisory Zones)**

1. Apply power to panel.
2. Slide the program switch down.
3. Press the FUNCTION button until the display reads "PASSWORD = 000."
4. To enter a password, press the SELECT button until the proper number is displayed above the "^" symbol; then press the SET button to move to the next digit. After entering the third number the display will change. (All panels are shipped with a "000" password.)
5. Press the FUNCTION button until the display reads "PROGRAM ##" (the second "#" character refers to the current program number between "0" and "24").
6. Press the SELECT button until the display reads "PROGRAM #7."
7. Press the SET button.
8. The panel is completely programmed except for the custom banner and some zone messages. Slide the program switch back up.

## **POTTER PROGRAM #7**

OUTPUTS	ZONES				
	*Supervisory 2	#1 Conventional	#2 Conventional	#3 Waterflow	#4 Low Air Supervisory
#1 ALARM		X	X		
#2 WATERFLOW				X	
#3 SUPERVISORY	X				X
#4 RELEASE		X	X		

INPUT: 2 conventional zones (cross-zoned), 1 waterflow zone, 1 low air zone, 1 supervisory zone.

OUTPUT: 1 general alarm bell, 1 waterflow bell, 1 supervisory bell, 1 solenoid release circuit.

OPERATION: Activation of both conventional zones at the same time will operate the solenoid release circuit and the general alarm bell.

Activation of either conventional zone will operate the general alarm bell.

Activation of the waterflow zone will operate the waterflow bell.

Activation of either the low air zone or the supervisory zone will operate the supervisory bell.

When either Zone #1 or #2 is in alarm, Output #1 (general alarm) will operate.

When Zones #1 and #2 are in alarm at the same time, Output #4 (solenoid release) and Output #1 (general alarm) will operate.

When Zone #3 is in alarm, Output #2 (waterflow bell) will operate.

When either Zone #4 or the supervisory zone is activated, Output #3 (supervisory bell) will operate.

**\* The Butterfly valve in the PrePaK assembly is connected to Supervisory 2 input of the Potter PFC-4410RC Releasing/Control panel.**

**Refer to the "Installation, Operation and Instruction Manual" for the PFC-4410-RC Releasing Control Panel for Additional Information.**

# POTTER PROGRAM #7 WIRING DIAGRAM

SINGLE HAZARD, CROSS ZONED, 2 ALARM ZONES  
1 WATERFLOW ZONE AND 2 SUPERVISORY ZONES

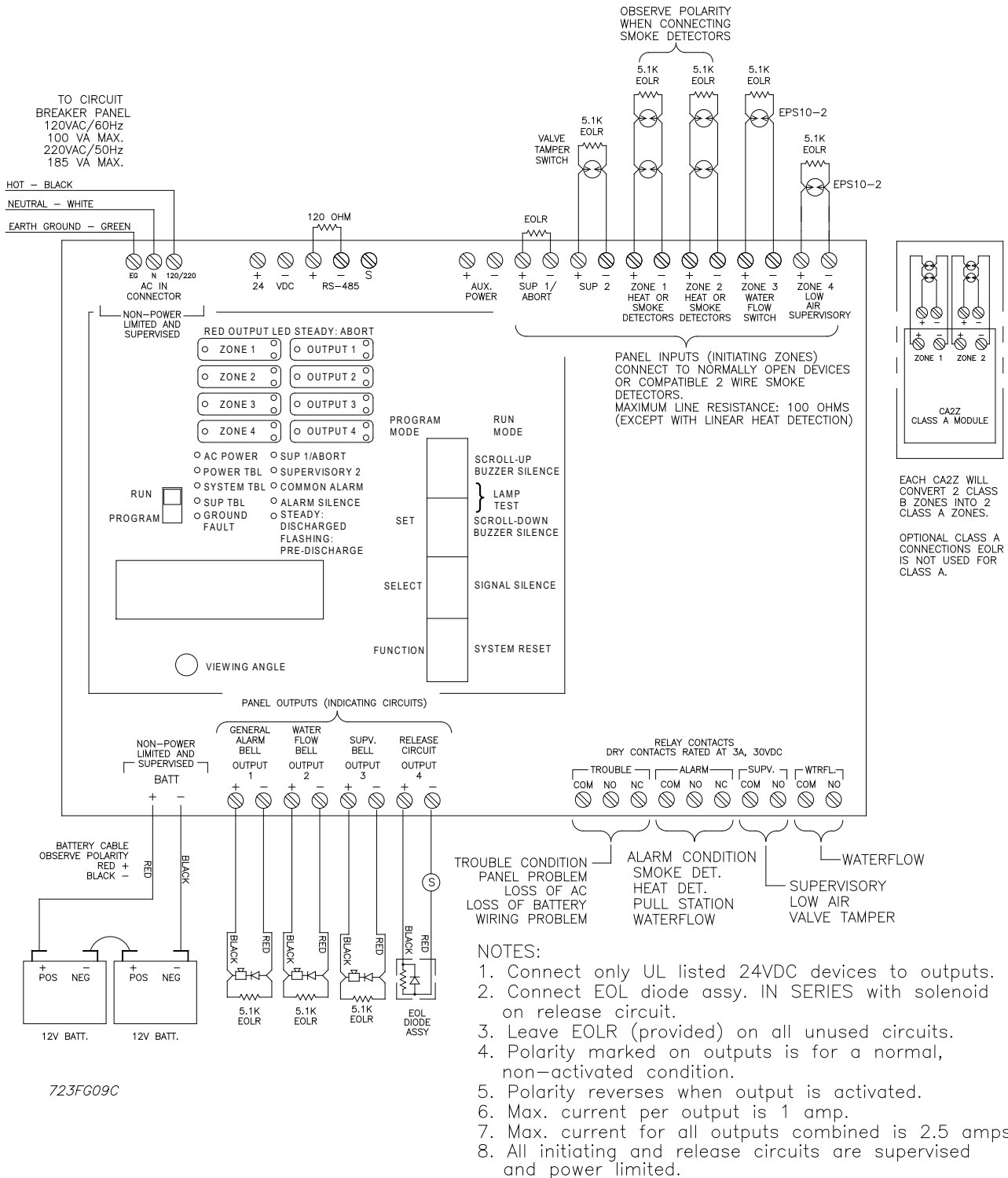

Figure 9—Wiring Diagram

## Potter Program #9

### Double Interlock Programming Instructions (Single Hazard, Cross Zoned, 2 Alarm Zones (1 Detection & 1 Low Air), 1 Waterflow Zone, and 1 Supervisory Zone)

1. Apply power to the panel.
2. Slide the program switch down.
3. Press the FUNCTION button until the display reads "PASSWORD=000."
4. To enter a password, press the SELECT button until the proper number is displayed above the "^" symbol; then press the SET button to move to the next digit. After entering the third number, the display will change. (All panels are shipped with a "000" password).
5. Press the FUNCTION button until the display reads "PROGRAM ##" (the second "#" character refers to the current program number between "0" and "24").
6. Press the SELECT button until the display reads "PROGRAM #9."
7. Press the SET button.
8. The panel is completely programmed except for the custom banner and zone messages. Slide the program switch back up.

## POTTER PROGRAM #9

OUTPUTS	ZONES				
	*Supervisory 2	#1 Conventional	#2 Low Air Supervisory (Empty)	#3 Waterflow	#4 Low Air Alarm
#1 ALARM		X			
#2 WATERFLOW				X	
#3 SUPERVISORY	X		X		X
#4 RELEASE		X			X

INPUT: 1 supervisory zone, 1 conventional detection zone, 1 low air supervisory zone, 1 waterflow zone, 1 low air alarm zone.

OUTPUT: 1 general alarm, 1 supervisory, 1 waterflow, 1 solenoid release circuit.

OPERATION: Activation of the conventional detection zone and the low air alarm zone at the same time will operate the solenoid release circuit and the general alarm bell.

Activation of the conventional zone only will operate the general alarm output.

Activation of the low air supervisory zone will operate the supervisory bell output.

Activation of the waterflow zone will operate the waterflow bell output.

Activation of the low air alarm zone will operate the supervisory bell output. It will not operate the alarm relay.

When Zone #1 is in alarm, Output #1 will operate.

When Zone #2 is activated, Output #3 will operate.

When Zone #3 is in alarm, Output #2 will operate.

When Zone #4 is activated, Output #3 will operate. This will create a supervisory condition not an alarm condition. The alarm relay will not operate, the supervisory relay will.

When both Zones #1 and #4 are activated at the same time, the solenoid circuit will operate.

**\* The Butterfly valve in the PrePaK assembly is connected to Supervisory 2 input of the Potter PFC-4410RC Releasing/Control panel.**

**Refer to the "Installation, Operation and Instruction Manual" for the PFC-4410-RC Releasing Control Panel for Additional Information.**

# POTTER PROGRAM #9 WIRING DIAGRAM

DOUBLE INTERLOCK, CROSS ZONED, 2 ALARM ZONES  
1 WATERFLOW ZONE AND 1 SUPERVISORY ZONE

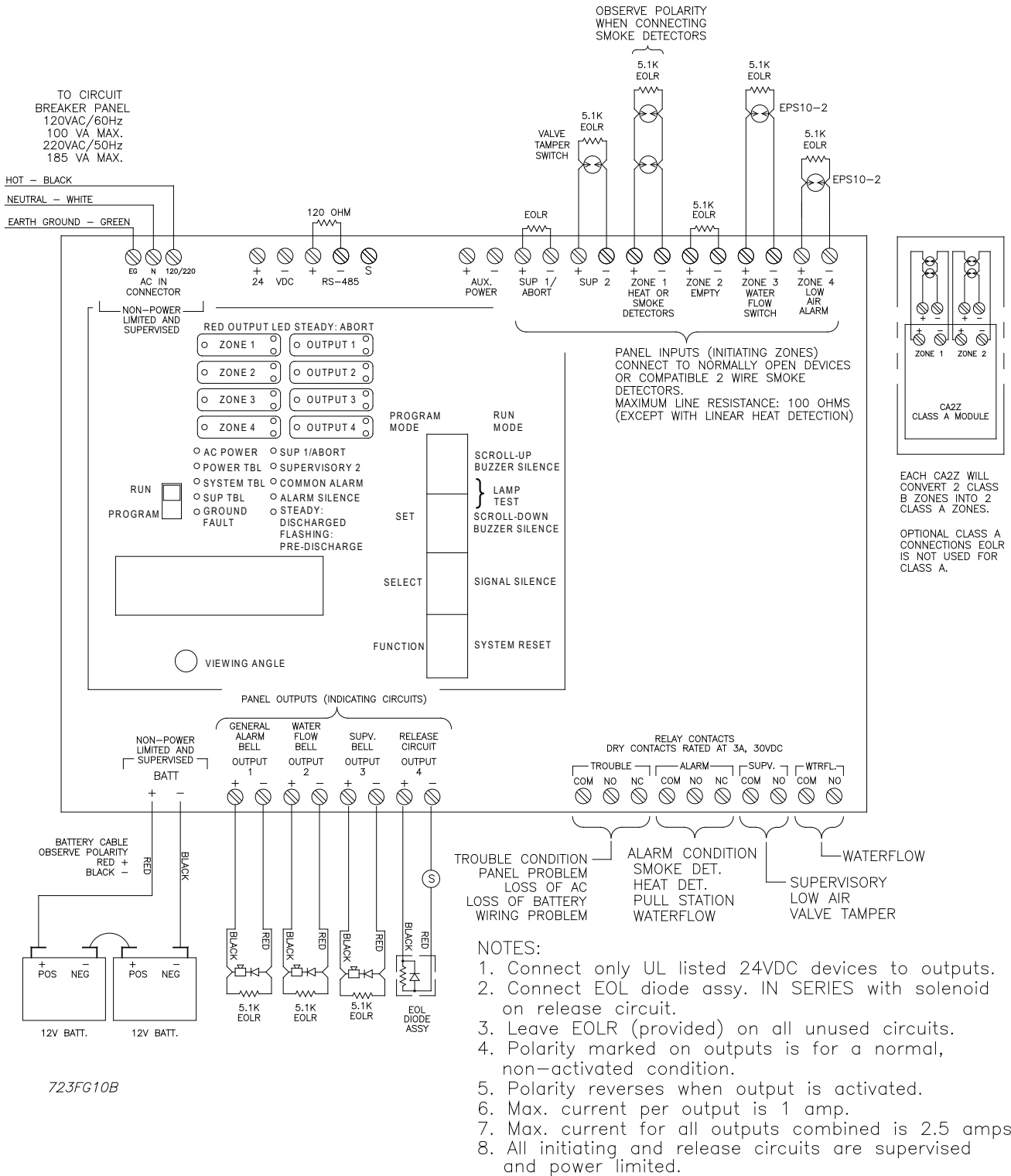

Figure 10—Wiring Diagram

## Potter Program #10

### Double Interlock Programming Instructions (Single Hazard, Cross Zoned, 3 Alarm Zones (2 Detection & 1 Low Air), 1 Waterflow Zone, and 1 Supervisory Zone)

1. Apply power to the panel.
2. Slide the program switch down.
3. Press the FUNCTION button until the display reads "PASSWORD=000."
4. To enter a password, press the SELECT button until the proper number is displayed above the "^" symbol; then press the SET button to move to the next digit. After entering the third number, the display will change. (All panels are shipped with a "000" password.)
5. Press the FUNCTION button until the display reads "PROGRAM ##" (the second "#" character refers to the current program number between "0" and "24").
6. Press the SELECT button until the display reads "PROGRAM #10."
7. Press the SET button.
8. The panel is completely programmed except for the custom banner and zone messages. Slide the program switch back up.

## POTTER PROGRAM #10

OUTPUTS	ZONES				
	*Supervisory 2	#1 Conventional	#2 Conventional	#3 Waterflow	#4 Low Air Alarm
#1 ALARM		X	X		
#2 WATERFLOW				X	
#3 SUPERVISORY	X				X
#4 RELEASE		X	X		X

- INPUTS: 1 supervisory zone, 2 conventional detection zones, 1 waterflow zone, and 1 low air alarm zone.
- OUTPUTS: 1 general alarm, 1 supervisory, 1 waterflow, and 1 solenoid release circuit.
- OPERATION: Activation of both conventional zones and the low air alarm zone at the same time will operate the solenoid release circuit and the general alarm bell.  
 Activation of either conventional zone only will operate the general alarm output.  
 Activation of the waterflow zone will operate the waterflow bell output.  
 Activation of the low air alarm zone will operate the supervisory bell output. It will not operate the alarm relay.  
 When either Zone #1 or #2 is in alarm, Output #1 will operate.  
 When Zone #3 is in alarm, Output #2 will operate.  
 When Zone #4 is activated, Output #3 will operate. This will create a supervisory condition not an alarm condition. The alarm relay will not operate, the supervisory relay will.  
 When Zones #1, #2 and #4 are activated at the same time, the solenoid release circuit will operate.

\* The Butterfly valve in the PrePaK assembly is connected to Supervisory 2 input of the Potter PFC-4410RC Releasing/Control panel.

**Refer to the "Installation, Operation and Instruction Manual" for the PFC-4410-RC Releasing Control Panel for Additional Information.**

# POTTER PROGRAM #10 WIRING DIAGRAM

DOUBLE INTERLOCK, CROSS ZONED, 3 ALARM ZONES  
1 WATERFLOW ZONE AND 1 SUPERVISORY ZONE

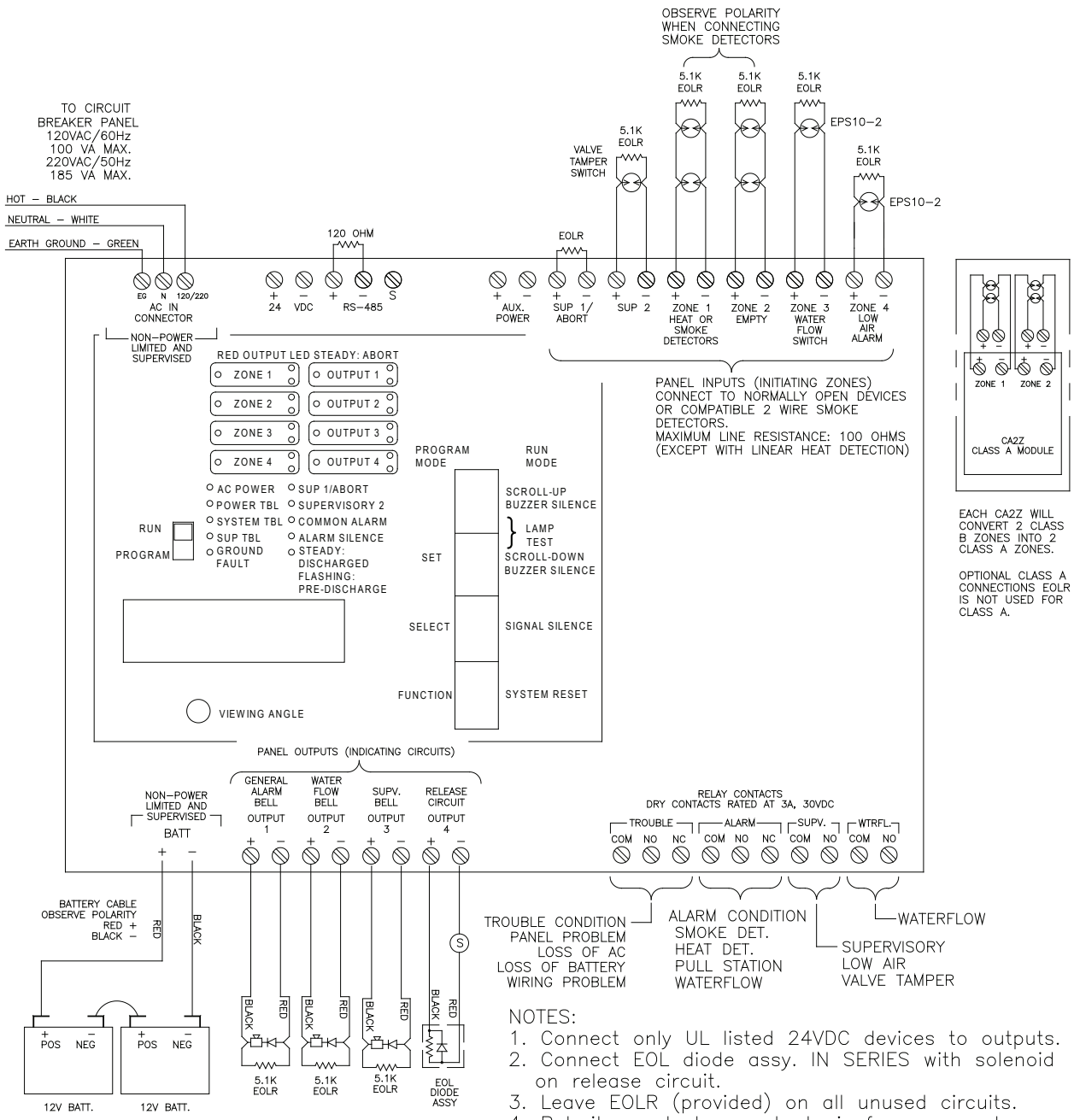

723FG11B

- NOTES:
1. Connect only UL listed 24VDC devices to outputs.
  2. Connect EOL diode assy. IN SERIES with solenoid on release circuit.
  3. Leave EOLR (provided) on all unused circuits.
  4. Polarity marked on outputs is for a normal, non-activated condition.
  5. Polarity reverses when output is activated.
  6. Max. current per output is 1 amp.
  7. Max. current for all outputs combined is 2.5 amps.
  8. All initiating and release circuits are supervised and power limited.

Figure 6 3/4 Double Interlock Preaction, Component Identification

## **Custom Program #1**

**(For New York City Compliance)**

### **Single Interlock Programming Instructions for New York City Compliance (Single Hazard, 2 Alarm Zones, 1 Waterflow Zone, and 2 Supervisory Zones)**

1. Apply power to the panel.
2. Slide the program switch down.
3. Press the FUNCTION button until the display reads "PASSWORD=000."
4. To enter a password, press the SELECT button until the proper number is displayed above the "^" symbol; then press the SET button to move to the next digit. After entering the third number, the display will change (All panels are shipped with a "000" password).
5. Press the FUNCTION button until the display reads "PROGRAM ##" (the second "#" character refers to the current program number between "0" and "24").
6. Press the SELECT button until the display reads "PROGRAM #6."
7. Press the SET button.
8. Slide the program switch up.
9. Slide the program switch down.
10. Apply steps 3 to 5.
11. Press the SELECT button until the display reads "PROGRAM #0."
12. Press the SET button.
13. Press the FUNCTION button until the display reads "OUTPUT 1: INDICATING."
14. Press the SET button until the display reads "OUTPUT #2: INDICATING."
15. Press the SELECT button until the display reads "TROUBLE BELL." Press the SET button.
16. Press the FUNCTION button until the display reads "ZONE 1 OUTPUTS." The "v" is pointing to the first available output for the zone indicated on the display. If the number is displayed, it is turned on for that zone. If the number is not displayed, the zone is turned off.
17. Press the FUNCTION button until the display reads "ZONE 3 OUTPUTS."
18. Press the SELECT button. The "1" should appear under the "v".
19. Press the SET button twice. The panel is completely programmed except for the custom banner and zone messages. If these messages are not desired, then slide the program switch back up.

## **POTTER PROGRAM #1**

OUTPUTS	ZONES				
	*Supervisory 2	#1 Conventional	#2 Manual release	#3 Waterflow	#4 Low Air Supervisory
#1 ALARM		X	X	X	
#2 WATERFLOW					
#3 SUPERVISORY	X				X
#4 RELEASE		X	X		

INPUTS: 1 conventional zones, 1 manual release zone, 1 waterflow zone, 1 low air zone, 1 supervisory zone.

OUTPUTS: 1 general alarm bell, 1 trouble bell, 1 supervisory bell, and 1 solenoid release circuit.

OPERATION: Activation of either the conventional zone or the manual release will operate the solenoid release circuit and the general alarm bell.

Activation of the waterflow zone will operate the general alarm bell.

Activation of either the low air zone or the supervisory zone will operate the supervisory bell.

A trouble condition (low battery, wiring problem, etc.) will operate the trouble bell.

When either Zone #1 or #2 is in alarm, Output #1 (general alarm) and Output #4 (solenoid release) will operate.

When Zone #3 is in alarm, Output #1 (alarm bell) will operate.

When either Zone #4 or the supervisory zone is activated, Output #3 (supervisory bell) will operate.

When the panel is in a trouble condition, Output # 2 (trouble bell) will operate.

**\* The Butterfly valve in the PrePaK assembly is connected to Supervisory 2 input of the Potter PFC-4410RC Releasing/Control panel.**

**Refer to the "Installation, Operation and Instruction Manual" for the PFC-4410-RC Releasing Control Panel for Additional Information.**

# CUSTOM PROGRAM #1

## WIRING DIAGRAM FOR NEW YORK CITY COMPLIANCE

### SINGLE INTERLOCK, 2 ALARM ZONES

### 1 WATERFLOW ZONE AND 2 SUPERVISORY ZONES

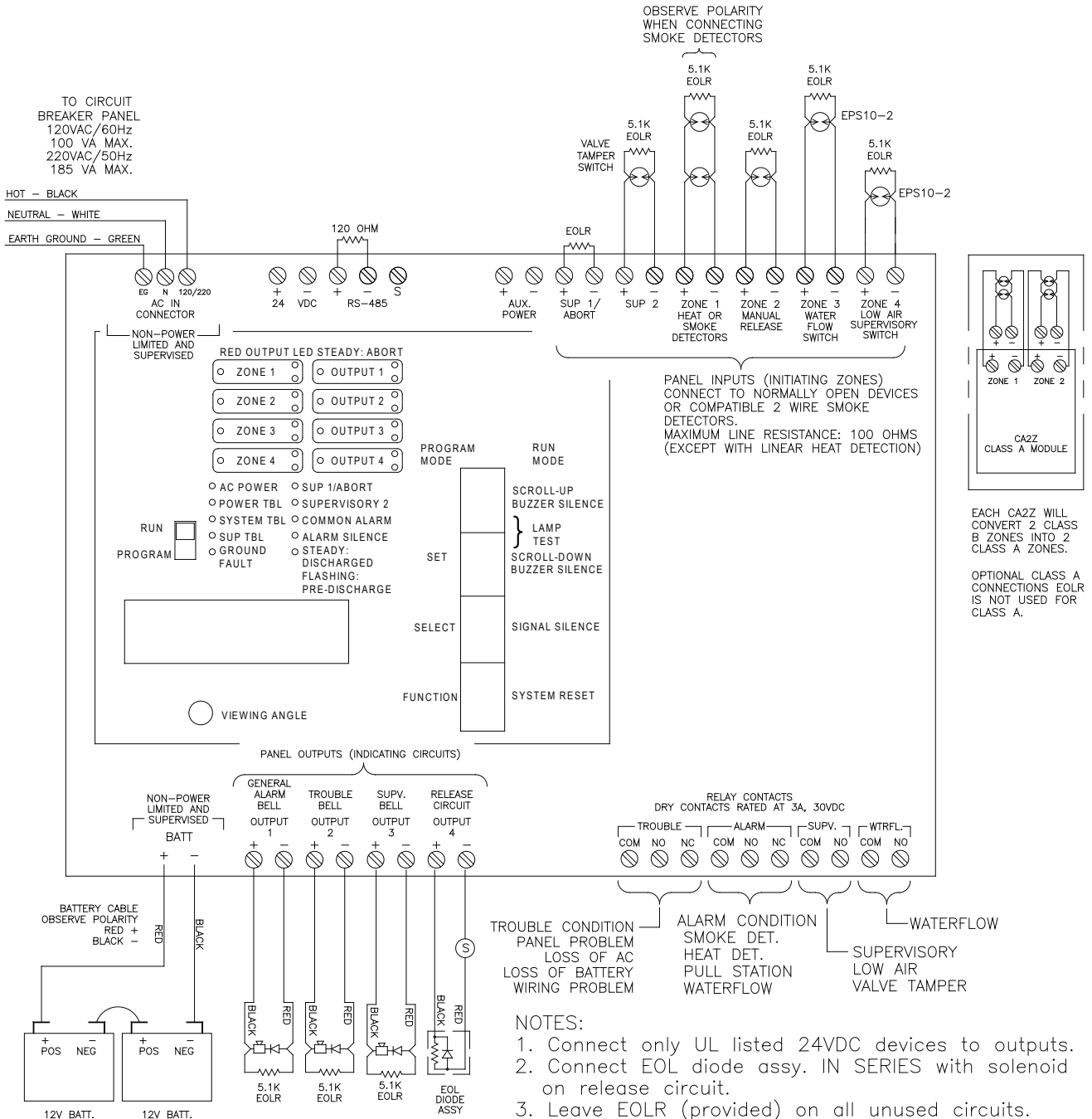

723FG12C

Figure 12—Wiring Diagram

## Ordering Information:

### Model H 1" (40 mm) PrePaK Part Number Code Key

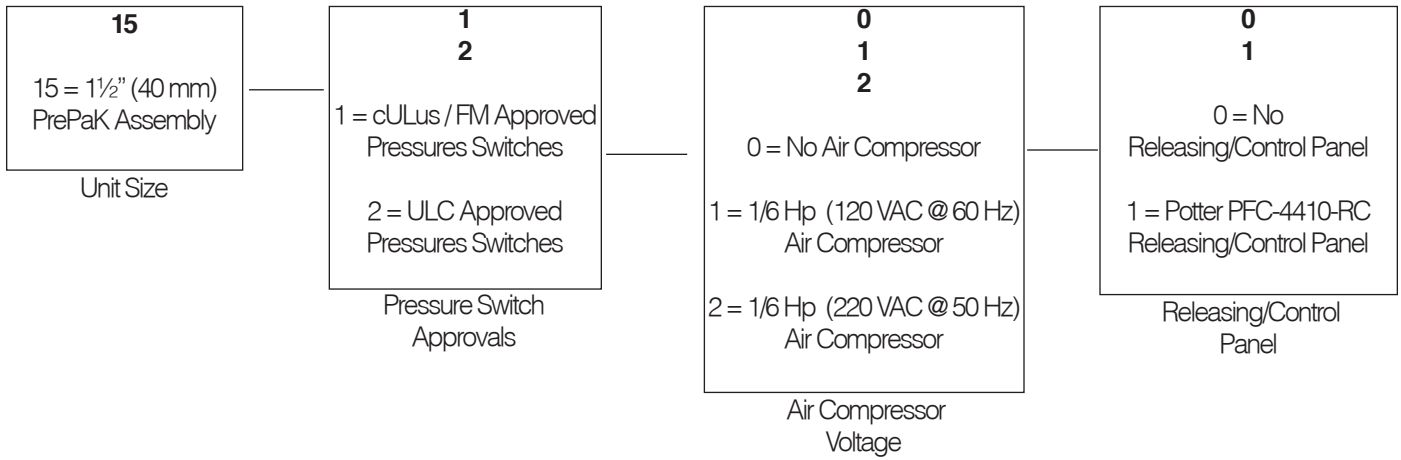

#### Example: 15 - 1 - 1 - 1

1½" (40 mm) Model H PrePaK Assembly, cULus / FM Approved Pressure Switches, 1/6 Hp Air Compressor Factory Wired to 120 VAC @ 60 Hz, and Potter PFC-4410-RC Releasing/Control Panel.

## **SOLENOID VALVE INSPECTIONS, TESTS AND MAINTENANCE**

**WARNING: THE OWNER IS RESPONSIBLE FOR MAINTAINING THE FIRE PROTECTION SYSTEM IN PROPER OPERATING CONDITION. ANY SYSTEM MAINTENANCE OR TESTING THAT INVOLVES PLACING A CONTROL VALVE OR DETECTION SYSTEM OUT OF SERVICE MAY ELIMINATE THE FIRE PROTECTION OF THAT SYSTEM. PRIOR TO PROCEEDING, NOTIFY ALL AUTHORITIES HAVING JURISDICTION. CONSIDERATION SHOULD BE GIVEN TO EMPLOYMENT OF A FIRE PATROL IN THE AFFECTED AREA.**

**WARNING: PRIOR TO OPERATING THE SOLENOID VALVE, BE SURE TO CLOSE THE SYSTEM CONTROL VALVE TO AVOID UNINTENTIONAL OPERATION OF THE DELUGE VALVE**

1. Inspections: It is imperative that the system be inspected and tested in accordance with NFPA 25 on a regular basis. The frequency of the inspections may vary due to contaminated water supplies, corrosive water supplies, or corrosive atmospheres. In addition, the alarm devices, detection systems, or other connected trim may require a more frequent schedule. Refer to the system description and applicable codes for minimum requirements.
2. The valve must be inspected at least monthly for cracks, corrosion, leakage, etc., and cleaned, repaired, or replaced, or replaced as necessary.
3. If leakage is suspected through the solenoid valve, the valve diaphragms and seats should be inspected and if necessary, repaired or replaced.

**WARNING: CLOSE SYSTEM CONTROL VALVE, TURN OFF POWER SUPPLY, AND DEPRESSURIZE VALVE BEFORE DISASSEMBLING VALVE. IT IS NOT NECESSARY TO REMOVE THE VALVE FROM THE PIPE LINE TO MAKE INSPECTIONS.**

4. When lubricating valve components, use high grade silicone grease (Dow Corning® 111 Compound Lubricant or equal).
5. When reassembling, tighten parts to torque values indicated in the manufacturer's maintenance instructions (packed with valve).
6. After maintenance is completed, operate the valve a few times to be sure of proper operation. A metallic "click" signifies the solenoid is operating.
7. All service must be performed by qualified personnel. Upon completion of inspections or replacement of the valve, the entire system must be checked for proper operation. See appropriate system description and testing instructions for additional information.

---

The equipment presented in this bulletin is to be installed in accordance with the latest published Standards of the National Fire Protection Association, Factory Mutual Research Corporation, or other similar organizations and also with the provisions of governmental codes or ordinances whenever applicable.

Products manufactured and distributed by Reliable have been protecting life and property for over 90 years, and are installed and serviced by the most highly qualified and reputable sprinkler contractors located throughout the United States, Canada and foreign countries.

---

Manufactured by

**Reliable®**

The Reliable Automatic Sprinkler Co., Inc.  
(800) 431-1588 Sales Offices  
(800) 848-6051 Sales Fax  
(914) 829-2042 Corporate Offices  
www.reliablesprinkler.com Internet Address



Recycled  
Paper

Revision lines indicate updated or new data.

EG. Printed in U.S.A 12/10

P/N 9999970145