

# Reliable®

**Model A**  
**Double Interlock**  
**Preaction System**  
**2½" (65mm) Size**

## Instructions for Installation, Operation, Care and Maintenance

**10 psi (0,7 bar) Pneumatic Supervising Pressure**  
**With Electric Pneumatic Actuation**  
**Controlled by a Cross-Zoned Releasing Control Panel**  
**Type D System**

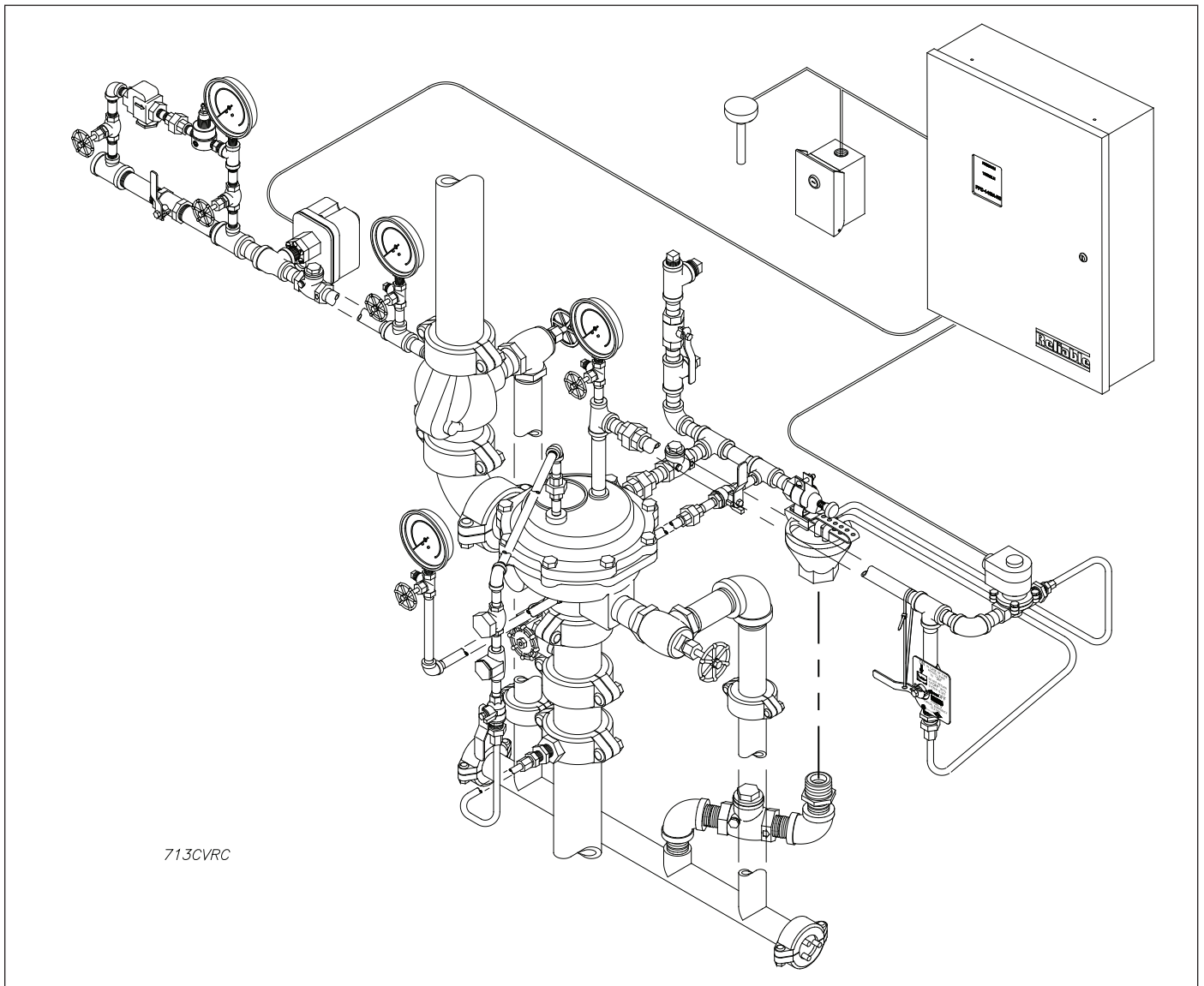

## General Description

Double Interlock Praction Systems are designed for water-sensitive areas which require the maximum protection from inadvertent water flow into the sprinkler system piping. A refrigerated area is an example of a water-sensitive environment.

To flow water into a Type D Double Interlock Praction System, two events must take place. A fire detection device must operate, and the low pressure switch must be operated by the loss of system pressure (sprinkler operation). These two signals must co-exist at the releasing control panel, which only then will energize the solenoid-releasing valve, causing water to flow into system.

The 2½" (65mm) Type D Double Interlock System utilizes the Reliable Model A Deluge Valve and the Model G Right-Check™ Valve. The Type D Double Interlock System uses fire detection devices and system air pressure as separate zones (inputs) to a cross-zoned releasing control panel. The Right-Check™ Valve isolates the deluge valve from the system to enable the system to be pressurized (supervised) with air or nitrogen and monitored by the low pressure switch. The solenoid-releasing valve remains closed until energized by the releasing control panel. This will occur only when both a fire detection device is operated and the low pressure switch has detected sufficient loss of system air pressure (sprinkler operation).

In the event that the system piping is ruptured or a sprinkler head is accidentally opened, the low-pressure switch will operate and an alarm will sound. The deluge valve, however, will not be released to flow water, since the solenoid releasing valve remains closed due to the cross-zoned control panel configuration.

In the event that a fire detection device is falsely operated, the control panel will activate an alarm. The deluge valve, however, will not be released to flow water, since the solenoid releasing valve remains closed due to the cross-zoned control panel configuration.

This requirement for both a detector to operate and the loss of air pressure before the deluge valve releases water into a preaction system assures maximum protection against inadvertent water flow before a sprinkler is open. Double Interlock Systems are primarily used to protect refrigerated areas where accidental water release before a sprinkler is open can cause ice blockage, resulting in an inoperative sprinkler system and substantial property damage.

The Model B Hydraulic Manual Emergency Station is standard equipment in the trim package. It consists of an aluminum nameplate mechanically attached to a ball valve. The valve handle on its OFF position is guarded against accidental turning to the ON position (and system discharge) by a nylon cable tie provided with the wet pilot trim kit. The cable tie is inserted as shown in Figure 3 after system has been restored for operation. The nylon cable tie is designed to allow, in case of an emergency, forceful turning of the valve handle to ON position.

The Model A Hydraulic Manual Emergency Pull Box is available as an option (see Bulletin 506).

The Optional Drain Manifold Trim (Figure 6) is available to facilitate an efficient drain system for all lines that must discharge to an atmospheric drain. It provides a 1¼" (32mm) drain outlet

with grooved end connections for easy installation and maintenance. It has been designed to fit a Reliable Model A Deluge Valve with grooved outlet only.

When a threaded outlet deluge valve is ordered, a thread-to-groove adapter nipple must be used to allow attachment of the 2½" (65mm) grooved end elbow which connects to the Model G Right-Check™ Valve.

## Approvals

The 2½" (65mm) Type D Double Interlock Praction System is Underwriters' Laboratories, Inc. Listed in the Special System Water Control Valves – Double Interlock Type (VLJH) category as a complete system.

The 2½" (65mm) Type D Double Interlock Praction System is a Factory Mutual Approved Refrigerated Area Sprinkler System for use in refrigerated rooms or buildings. Refrigerated area sprinkler systems are FM Approved as complete systems. Systems are FM Approved for use with thermal detectors and Class A detector wiring only.

The Reliable Double Interlock Praction System is UL Listed and FM Approved only when used with the trim components shown in Figure 3 or 4.

The components of Double Interlock Praction Systems are individually listed by Underwriters' Laboratories of Canada.

NYC MEA 258-93-E.

## Technical Data

The 2½" (65mm) Type D Double Interlock Praction System, with associated trim, is rated for a minimum water supply pressure of 20 psi (1,4 bar) and a maximum water supply pressure of 175 psi (12 bar).

Friction loss, expressed in equivalent length of Sch. 40 pipe and based on Hazen-Williams formula with C=120 and a flowing velocity of 15 ft/s (4.6 m/s), is:

Model A Deluge Valve - 17.1 ft. (5.21 m)

Model G Right-Check™ Valve - 7 ft. (2.13 m)

90° 2½" elbow - 6 ft. (1.83 m)

The following list of Technical Data Sheets describe the valves and devices which are used in the Double Interlock Praction System:

|  |                 |
|--|-----------------|
| Deluge Valve                                     | 502/503         |
| Right-Check™ Riser Valve                         | 806             |
| Wet Pilot Trim Set                               | 503             |
| Low Air Pressure Switch (System Sensor)          | A05-0176        |
| Hydraulic Emergency Station                      | 506             |
| Mechanical Sprinkler Alarm                       | 612/613         |
| Solenoid Valve                                   | 718             |
| Water Flow Pressure Alarm Switch (System Sensor) | A05-0176        |
| Pressure Maintenance Device                      | 250/251         |
| Compressor                                       | 275/700         |
| Releasing/Control Panel                          | Potter #5403550 |
| Electric Emergency Station                       | 700             |
| Thermal Detectors                                | 722             |
| Fire Alarm Devices                               | 700             |

## System Design Considerations

The automatic sprinklers, air compressor, releasing devices, electric releasing control equipment, fire detection devices, manual pull stations, and signaling devices, which are utilized with the Double Interlock Systems must be UL Listed, ULC Listed or FM Approved, as applicable.

Factory Mutual Research Corporation requires that detection devices in refrigerated areas be of the fixed-temperature type. In addition, they must have a temperature rating lower than that of the sprinklers and, preferably, as low as possible for the given ambient conditions.

The deluge valve, check valve, and all interconnecting piping must be located in a readily visible and accessible location and in an area which can be maintained at a minimum temperature of 40°F(4°C). Note: Heat tracing is not permitted.

The solenoid valve is operated and supervised by the electric releasing control panel. Details on the electrical portion of this system can be found in "HydroStatic Testing of Systems" Reliable Bulletin 700, "Special Hazards & Special Systems."

## Hydrostatic Testing of Systems

As required by NFPA 13, fire sprinkler systems with working pressures up to and including 150 psi are to be hydrostatically tested at a water pressure of 200 psi and maintain that pressure without loss for two hours. Fire sprinkler systems with working pressures above 150 psi are required to be hydrostatically tested at 50 psi above the system working pressure and maintain that pressure without loss for two hours. In addition to the hydrostatic tests described above, dry pipe and double interlock preaction systems require an additional low pressure air test.

In some cases, hydrostatic testing (in accordance with the NFPA 13 requirements noted above) will result in pressures that exceed the working pressure of the valve and trim kit for the two-hour test period. The valve and applicable trim kit have been tested, approved and listed under these conditions and as such, hydrostatic testing in accordance with NFPA 13 is acceptable. In addition, the clapper can remain in the closed position and the trim kit need not be isolated, as each has been designed to withstand hydrostatic testing as required by NFPA 13.

Hydrostatically testing the valve and trim to pressures higher than their rating is limited to the hydrostatic test as referenced by NFPA 13. It does not address the occurrence(s) of a "water hammer" effect, which can indeed damage the valve. A "water hammer" in the water supply piping of the valve can create pressures in excess of the rated pressure and should be avoided by all necessary means. This condition may be created from improper fire pump settings, underground construction work, or an improper venting of trapped air in the water supply piping.

## System Air Pressure Requirements

In accordance with NFPA 13, double interlock preaction systems require a minimum of 7 psi (0,5 bar) pneumatic pressure to supervise the sprinkler system. The Model A-2 Pressure Maintenance Device is used to maintain the system pneumatic pressure between 7 and 10 psi (0,5 and 0,7 bar) where a dry nitrogen gas supply or a clean, dependable and continuous (24 hours per day, 7 days per week) compressed air source is available.

To adjust the system air pressure to between 7 and 10 psi (0,5 and 0,7 bar), refer to Reliable Bulletin 251. The low-pressure alarm switch (Item 21, Figure 3) is factory set to operate between 8 and 4 psi (0,55 and 0,28 bar) with decreasing pressure. If necessary, adjustments can be made by following the procedure described in Bulletin A05-0176 enclosed with the switch.

**Note:** The dew point of the air must be maintained below the lowest ambient temperature to which the double interlock system piping will be exposed. Introduction of moisture into the system piping that is exposed to freezing temperatures can create ice blockage, which could prevent proper operation of the system. At a minimum, the supply of the air should be taken from the refrigerated area at the lowest temperature. The air supply system must be carefully designed to prevent plugging by frost deposits. Special requirements such as those in FME&R'S Installation Guidelines for Refrigerated Storage may need to be incorporated.

Because the Type D System is designed to use low pneumatic pressure, bottled dry nitrogen is the economical method of pneumatic supply. Please see Reliable Bulletin 253 for nitrogen regulator equipment and system volume requirements.

Whenever multiple Praction Systems are installed at the same location, it is strongly recommended that each system have its own Model A-2 Pressure Maintenance Device for individual maintenance of air pressure.

## System Electrical Requirements

All releasing and detection devices in the Type D Double Interlock System are supervised by the Potter PFC-4410-RC Releasing Control Panel. Typical connections of these devices are shown in Figure 6. Connect the C and NC terminals of the system low pressure switch (Figure 5) to initiating Zone 2 as shown in Figure 1 or 2. These contacts must be in the open position when the system is pneumatically pressurized. Install fire detection devices to initiating Zone 1 as shown in Figure 1 or 2.

The power supply, the standby emergency power supply, battery charger and the rectifier circuitry are all contained within the panel. Batteries that provide 90 hours of standby power are required for FM systems.

For additional information and detailed wiring diagrams, refer to Reliable Bulletin 700.

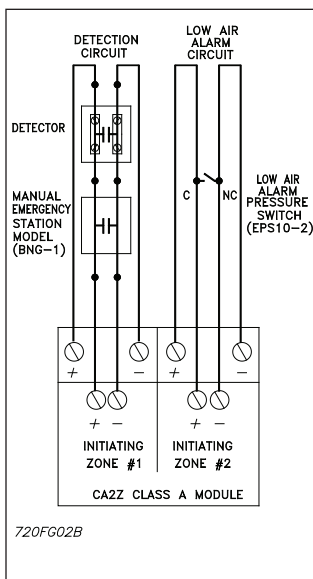

Class A Wiring  
Figure 1

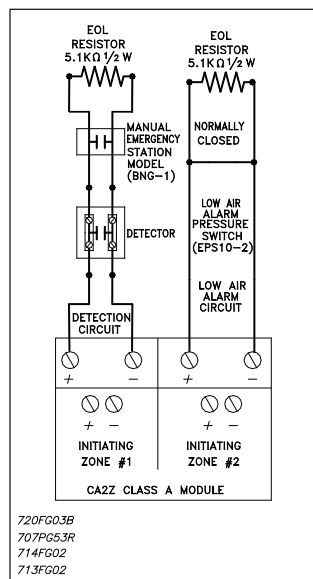

Class b Wiring  
Figure 2

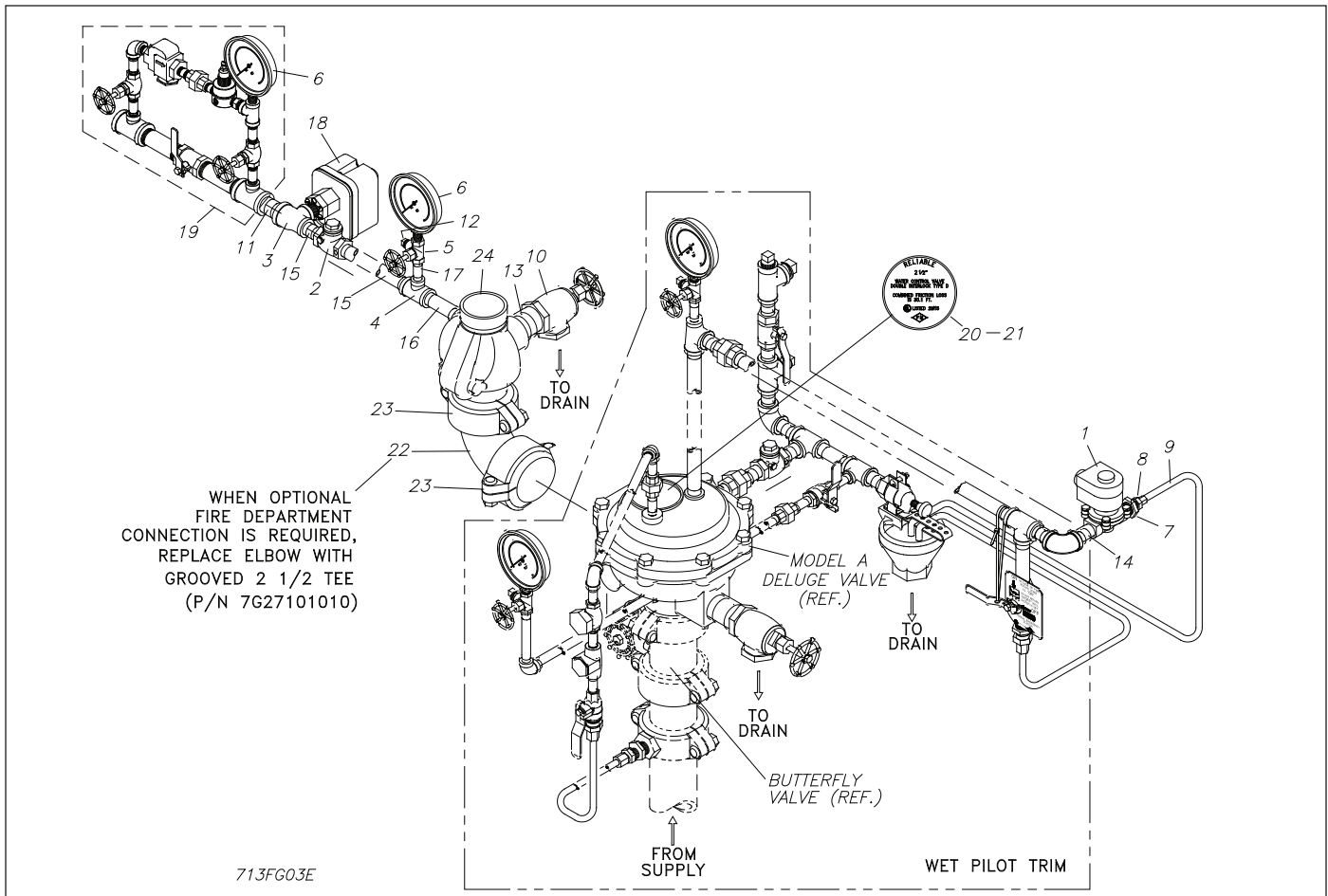

Figure 3 - Type D Double Interlock Trim Kit

**Loose Parts: P/N 6503002400 / P/N 6503002430 (Canadian)**

**Preassembled Parts: P/N 6503002401 / P/N 6503002431 (Canadian)**

| Item No. | Part No.   | Description                             | No. Req'd |
|----------|------------|---|-----------|
| 1        | 6871020000 | Valve, Solenoid                         | 1         |
| 2        | 98840181   | Valve, Horiz. Check, 1/2"               | 1         |
| 3        | 96606612   | Tee, 3/4" x 1/2" x 1/2"                 | 1         |
| 4        | 96606607   | Tee, 1/2" x 1/2" x 1/4"                 | 1         |
| 5        | 98840160   | Valve, Gauge, 3 - Way, 1/4"             | 1         |
| 6        | 98248000   | Gauge, Pressure, Air                    | 2         |
| 7        | 98048000   | Bushing, Reducer, 1/2" x 1/4"           | 1         |
| 8        | 92056702   | Connector, 3/8" O.D. x 1/4" NPT         | 1         |
| 9        | 96686707   | Tubing/Tag S/A, 3/8" O.D. x 2 ft.       | 1         |
| 10       | 98840106   | Valve, Angle, 1/4"                      | 1         |
| 11       | 98543279   | Nipple, 3/4" x Close                    | 1         |
| 12       | 98614403   | Plug, 1/4"                              | 1         |
| 13       | 98543239   | Nipple, 1/4" x 3" LG.                   | 1         |
| 14       | 98543223   | Nipple, 1/2" x 1 1/2" LG.               | 1         |
| 15       | 98543212   | Nipple, 1/2" x Close                    | 2         |
| 16       | 98543216   | Nipple, 1/2" x 3 1/2" LG.               | 1         |
| 17       | 98543226   | Nipple, 1/4" x 1 1/2" LG.               | 1         |
| 18       | 6999991339 | Switch, Pressure (EPS 10-1)             | 1         |
|          | 6999992366 | Switch, Pressure (EPS 10-1) (Canadian)  |           |
| 19       | 6304000100 | Air Maintenance Device, Model A-2       | 1         |
| 20       | 94616905   | Nameplate, Double Intlk. Type D, 2 1/2" | 1         |
| 21       | 99080002   | Pad, Adhesive                           | 1         |
| 22       | 7G23101000 | Elbow, 90°, 2 1/2"                      | 1         |
| 23       | 7G05101000 | Coupling, Rigid, 2 1/2"                 | 2         |
| 24       | 6107020000 | Model G Check Valve Riser, 2 1/2"       | 1         |

## System Operation

The 2½" (65mm) Type D Double Interlock Preaction System requires two independent events to co-exist before water flow will occur. A fire detection device must be operated and the low pressure switch must be actuated by reducing the system pressure (sprinkler operation) to cause the cross-zoned control panel to energize the solenoid valve to release water through the deluge valve into the system.

When a double interlock system is set for service, the supply pressure in the top chamber acts across the diaphragm and the piston, holding the piston on the seat against the inlet supply pressure. The diaphragm pressure area is greater than the seat pressure area, providing a force imbalance of about 3 to 1.

When a fire is detected, the top chamber is vented to the atmosphere through the outlet port via opened actuation devices. The top chamber pressure cannot be replenished through the restricted inlet port, and the chamber pressure falls instantaneously. When the top chamber pressure reaches about 1/3 the supply pressure, the upward force of the supply pressure acting on the piston becomes greater than the downward force

of the diaphragm and the piston moves up to the open position. Refer to Reliable Bulletins 502 and 503 for further details.

Once the piston has opened, water flows from the supply through the deluge valve into the piping system and the alarm outlet to the alarm devices. The valve maintains its open position until the open releasing device is closed.

**CAUTION: THE RELEASING DEVICE MUST BE MAINTAINED OPEN TO PREVENT CLOSING OF THE MODEL A DELUGE VALVE.**

After system shutdown, the valve is easily reset without special tools by restoring operated detection devices to the set position (by resetting or replacing the device). Once the detection device is set and supply pressure is re-supplied to the top chamber, the deluge valve will be closed.

The Type Double Interlock Preaction System will automatically operate only when both a fire detection device and the system low pressure switch are activated. Operation of either one of these initiating devices will only cause an alarm to annunciate and will not fill the sprinkler system piping with water.

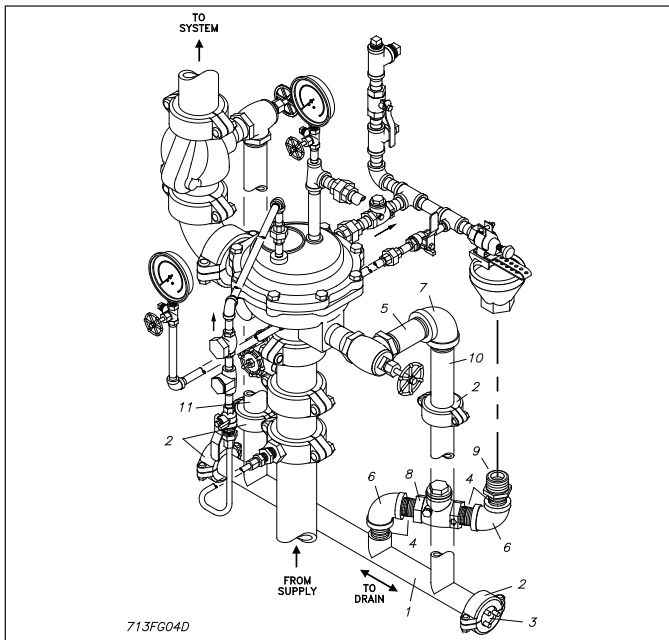

Figure 4 - Optional Drain Manifold

## Double Interlock Trim Installation

The recommended sequence of installation is as follows (Refer to Figure 3):

1. Install the Wet Pilot Trim in accordance with Bulletin 503, "Model A Deluge Valve" and the Installation Sheet included with the wet pilot trim kit.
2. Install Model G Right-Check™ Valve with flow direction arrow pointing up.
3. Install the double interlock trim kit as shown in Figure 3.
4. Attach the Name Plate (20) with Adhesive Pad (21) on the cover of the deluge valve, as shown.
5. Connect the air supply to the Reliable Model A-2 Pressure Maintenance Device (19) after it is connected to Pressure Switch (18).

## Maintenance

Type D Double Interlock Systems and associated equipment shall periodically be given a thorough inspection and test. NFPA 25, Inspection, Testing and Maintenance of Water Based Fire Protection Systems, provides minimum maintenance requirements. The double interlock system shall be tested, operated, cleaned and inspected at least annually and parts replaced as required.

## Resetting Double Interlock System

Refer to Figure 5

1. Close main valve controlling water supply to the deluge valve and close valves controlling system pneumatic pressure in the Model A-2 Pressure Maintenance Device.
2. Check that top chamber supply Valve A is closed.
3. Open Drain Valve C and drain system above the check valve.
4. Open Drain Valve B and drain system below the check valve.
5. Open all drain valves and vents at low points throughout the system, closing them when flow the water has stopped.
6. Open Valve D, relieving pressure in the top chamber.

| Item No. | Part Number | Description                | Qty. Req'd |
|----------|-------------|----------------------------|------------|
| 1        | 91002440    | Manifold, S/A, Drain, 1¼"  | 1          |
| 2        | 7203050500  | Coupling, 1¼"              | 4          |
| 3        | 7325050000  | Cap, Coupling, 1¼"         | 1          |
| 4        | 98543213    | Nipple, 1" x Close         | 4          |
| 5        | 98543250    | Nipple, 1¼" x 4"           | 1          |
| 6        | 98174414    | Elbow, 1¼"                 | 1          |
| 7        | 98174403    | Elbow, 1"                  | 2          |
| 8        | 98840145    | Valve, Check, 1"           | 1          |
| 9        | 98048026    | Bushing, Reducer 1¼"       | 1          |
| 10       | 95190162    | Pipe, 1¼" Grv. & Thd x 6¾" | 1          |
| 11       | 95191534    | Pipe, 1¼" Grv. & Thd x 16" | 1          |

7. Push in plunger of Ball Drip Valve G to force the ball from its seat, and drain any water in the alarm line.
8. Reset the deluge valve in accordance with Bulletin 503, "Model A Deluge Valve Instructions for Installation, Operation, Care and Maintenance."
9. Inspect and replace any portion of the detection system exposed to fire conditions.
10. Open Valve A and allow water to fill the top chamber. Close Valve D.
11. Bleed all air from the actuating piping by opening the solenoid valve (this can be accomplished by operating a detector while the system low pressure switch is operating due to low pressure in the system). Close the solenoid valve when a steady stream of water flows through. Resetting the detector, low pressure switch and the Potter PFC-4410-RC Releasing Control Panel in this order will close the solenoid valve. (Refer to Bulletin 700 for details).  
**Note:** All detection devices must be reset before the panel can be reset.
12. Open Model A-2 Pressure Maintenance Device valves to restore system pneumatic pressure. This will reset the low pressure switch when 7 to 10 psi (0,5 and 0,7 bar) is maintained.
13. Open slightly the main valve controlling water supply to the deluge valve, closing Main Drain Valve B when water flows. Observe if water leaks through Ball Drip Valve G into Drip Cup H. If no leak occurs, the water seat is tight. Open slowly but fully the valve controlling water supply to the deluge valve, and verify the valve is supervised in the OPEN position.
14. Verify Valve A is open.

## Inspection and Testing

Refer to Figure 5

1. Water supply – be sure the valves controlling water supply to the deluge valve are open fully and sealed in this position.
2. Alarm line – be sure Valve E is open and sealed in this position.
3. Other trimming valves – check that Valve A and the pressure gauge valves are open and Valve F is closed.
4. Ball drip valve – push in on the plunger of Valve G to confirm the ball check is off its seat. If no water appears, the deluge valve water seat is tight.
5. Check that system air pressure is between 7 and 10 psi.
6. Releasing device – check outlet of releasing device (i.e. solenoid valve, or hydraulic manual emergency station/pull box) for leakage and proper pressure. Check the air maintenance device for leakage and proper pressure. Also, verify that tubing drain lines from releasing devices are not pinched or crushed, which could prevent proper releasing of the preaction system.

7. Testing alarms – open Valve F, permitting water from the supply to flow to the electric sprinkler alarm switch and to the mechanical sprinkler alarm (water motor). After testing, close Valve F securely. Push in on the plunger of Valve G until all of the water has drained from the alarm line.
8. Operation test – open drain Valve D or operate by the electrical actuation (refer to Bulletin 700, "Special Hazards & Special Systems" for details).  
**Note:** Operation test will cause the deluge valve to trip. Where difficulty in performance is experienced, contact Reliable if any field adjustment is to be made.

## Testing Detection System Without Operating Deluge Valve

Refer to Figure 5

1. Close the main control valve controlling water supply to the deluge valve, and open 1¼" drain Valve B.
2. Open Valve A, allowing water to enter to the top chamber.
3. Operate detection systems – operate the cross-zoned control panel by operating both a detector and the low pressure switch (refer to Bulletin 700, "Special Hazards & Special Systems" for details).
4. Operation of the detection systems must result in a sudden drop of water pressure in the deluge valve top chamber.
5. Reset detection system – reverse operations performed in Step "3" above.
6. Open slightly the valve controlling water supply to the deluge valve, closing Drain Valve B when water flows. Open slowly but fully the valve controlling water supply to the deluge valve, and verify the valve is supervised in the open position.
7. Check Ball Drip Valve G to verify there is no leakage. Push in on its plunger to confirm the ball check is off its seat. If no water appears, the deluge valve water seat is tight.



## Ordering Information

Specify:

| Item No.                       | Component Part                          | Mfg.    | Description  | Technical Bulletin                |
|--------------------------------|---|---------|--|-----------------------------------|
| 1                              | Water Supply Control Valve              | Select  | OS&Y, 2½" (65mm)                                     | -                                 |
|                                |   |         | Milwaukee Model BBCSCS02 2½" (65mm) w/ Tamper        | -                                 |
|                                | Tamper Switch (Optional) for OS&Y Valve | D       | Model OS&Y2  | System Sensor A05-0196            |
| (Optional) for Butterfly Valve | Model P1BV2                             |         | System Sensor A05-0197                               |                                   |
| 2                              | Deluge Valve                            | B       | Model A, 2½" (65mm), GExGE or THDx THD               | Reliable 502 / 503                |
| 3                              | Double Interlock Trim Kit               | B       | Refer to Parts List in this Bulletin                 | Reliable 713                      |
| 4                              | Waterflow Alarm Pressure Switch         | D       | Model EPS10-2 (DPDT, UL, FM)                         | System Sensor A05-0176            |
|                                |   |         | Model EPESA10-2 (DPDT, ULC)                          |                                   |
| 5                              | Mechanical Alarm (Optional)             | B       | Model C  | Reliable 612 / 613                |
| 6                              | Releasing / Control Panel               | C       | Model PFC-4410-RC                                    | Potter #5403550<br>Reliable 700   |
|                                | Batteries                               |         | 12 VDC, 12 AMP Hours (90 Hours Backup) FM            |                                   |
|                                |   |         | 12 VDC, 7 AMP Hours (60 Hours Backup)                |                                   |
|                                | Optional Accessories                    |         | CA2Z (Class A Wiring Module for Initiating Circuits) |                                   |
|                                |   |         | CAM (Class A Wiring Module for Indicating Circuits)  |                                   |
|                                |   |         | ARM-1 / ARM-2 (Auxiliary Relay Module)               |                                   |
|                                | RA-4410-RC (Remote Annunciator)         |         |  |                                   |
| 7                              | Alarm Annunciator                       | A       | Model SSM24-8 24 VDC / Polarized Bell                | Reliable 700                      |
|                                |   |         | Model SSM24-10 24 VDC / Polarized Bell               |                                   |
|                                |   |         | Model MA24-D 24 VDC / Polarized Sounder              |                                   |
|                                |   |         | Model MASS24LO 24 VDC / Polarized Sounder Strobe     |                                   |
| 8                              | Trouble Annunciator                     | A       | Model SSM24-6 24 VDC / Polarized Bell                | Reliable 700                      |
|                                |   |         | Model MA24-D 24 VDC / Polarized Sounder              |                                   |
| 9                              | Manual Emergency Station (Elec.)        | A       | Model BNG-1 (SPDT) 1 & 2 Area Detection              | Reliable 700                      |
|                                |   |         | Model BNG-1F (DPDT) Cross Zoned Detection            |                                   |
| 10                             | Detection                               | Various | Smoke, Heat Detectors, etc.                          | Reliable 722                      |
| 11                             | Sprinklers                              | B       | Closed Type  | Reliable 110, 117, 131, 136, etc. |
| 12                             | Air Compressor with Tank                | E       | Model 1LAA-11T-M100X, 1/6 Hp w/ 2 Gallon Tank        | F30                               |
| 13                             | Nitrogen Regulating Device              | B       | Regulator with Optional Low Air Pressure Switch      | Reliable 253                      |
| 14                             | Drain Manifold Kit                      | B       | Model A, GExGE Only                                  | Reliable 503/503                  |

## System Equipment Manufacturers

(A) (Notifier, Division of Pittway Corporation)

(D) (The Reliable Automatic Sprinkler Co., Inc.)

(E) (United Electric Controls Company)

(G) (System Sensor, Division of Pittway)

(H) (Thermotech, Inc.)

(I) (Gast Manufacturing Corporation)

## TYPE D DOUBLE INTERLOCK PREACTION SYSTEM ELECTRICAL CONNECTIONS

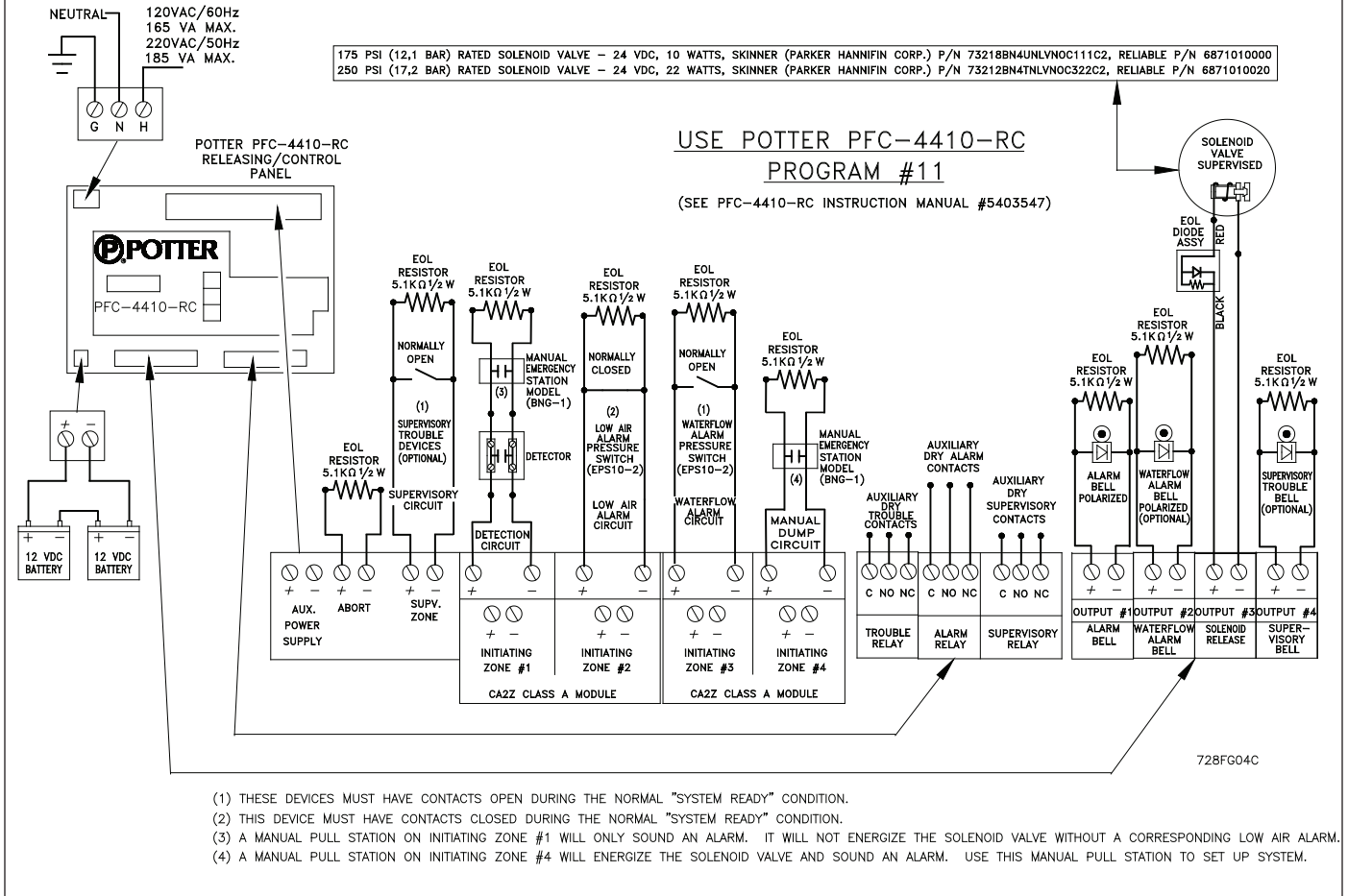
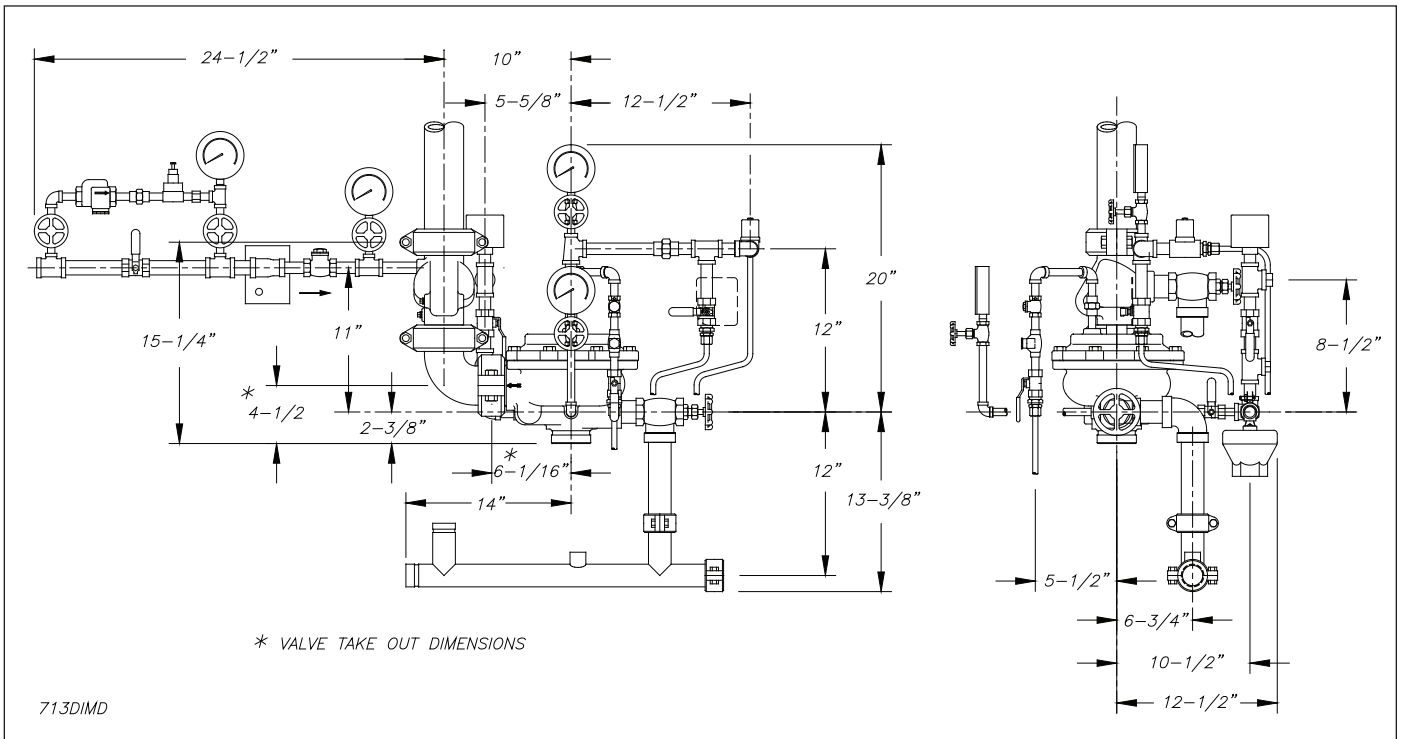

Figure 6 - Wiring Diagram

## Installation Dimension in Inches



## **SOLENOID VALVE INSPECTIONS, TESTS AND MAINTENANCE**

**WARNING: THE OWNER IS RESPONSIBLE FOR MAINTAINING THE FIRE PROTECTION SYSTEM IN PROPER OPERATING CONDITION. ANY SYSTEM MAINTENANCE OR TESTING THAT INVOLVES PLACING A CONTROL VALVE OR DETECTION SYSTEM OUT OF SERVICE MAY ELIMINATE THE FIRE PROTECTION OF THAT SYSTEM. PRIOR TO PROCEEDING, NOTIFY ALL AUTHORITIES HAVING JURISDICTION. CONSIDERATION SHOULD BE GIVEN TO EMPLOYMENT OF A FIRE PATROL IN THE AFFECTED AREA.**

**WARNING: PRIOR TO OPERATING THE SOLENOID VALVE, BE SURE TO CLOSE THE SYSTEM CONTROL VALVE TO AVOID UNINTENTIONAL OPERATION OF THE DELUGE VALVE**

1. Inspections: It is imperative that the system be inspected and tested in accordance with NFPA 25 on a regular basis. The frequency of the inspections may vary due to contaminated water supplies, corrosive water supplies, or corrosive atmospheres. In addition, the alarm devices, detection systems, or other connected trim may require a more frequent schedule. Refer to the system description and applicable codes for minimum requirements.
2. The valve must be inspected at least monthly for cracks, corrosion, leakage, etc., and cleaned, repaired, or replaced, or replaced as necessary.
3. If leakage is suspected through the solenoid valve, the valve diaphragms and seats should be inspected and if necessary, repaired or replaced.

**WARNING: CLOSE SYSTEM CONTROL VALVE, TURN OFF POWER SUPPLY, AND DEPRESSURIZE VALVE BEFORE DISASSEMBLING VALVE. IT IS NOT NECESSARY TO REMOVE THE VALVE FROM THE PIPE LINE TO MAKE INSPECTIONS.**

4. When lubricating valve components, use high grade silicone grease (Dow Corning® 111 Compound Lubricant or equal).
5. When reassembling, tighten parts to torque values indicated in the manufacturer's maintenance instructions (packed with valve).
6. After maintenance is completed, operate the valve a few times to be sure of proper operation. A metallic "click" signifies the solenoid is operating.
7. All service must be performed by qualified personnel. Upon completion of inspections or replacement of the valve, the entire system must be checked for proper operation. See appropriate system description and testing instructions for additional information.

---

The equipment presented in this bulletin is to be installed in accordance with the latest published Standards of the National Fire Protection Association, Factory Mutual Research Corporation, or other similar organizations and also with the provisions of governmental codes or ordinances whenever applicable.

Products manufactured and distributed by Reliable have been protecting life and property for over 90 years, and are installed and serviced by the most highly qualified and reputable sprinkler contractors located throughout the United States, Canada and foreign countries.

---

Manufactured by

**Reliable®**

The Reliable Automatic Sprinkler Co., Inc.  
(800) 431-1588 Sales Offices  
(800) 848-6051 Sales Fax  
(914) 829-2042 Corporate Offices  
www.reliablesprinkler.com Internet Address



Recycled  
Paper

Revision lines indicate updated or new data.

EG. Printed in U.S.A 12/10

P/N 9999970065