

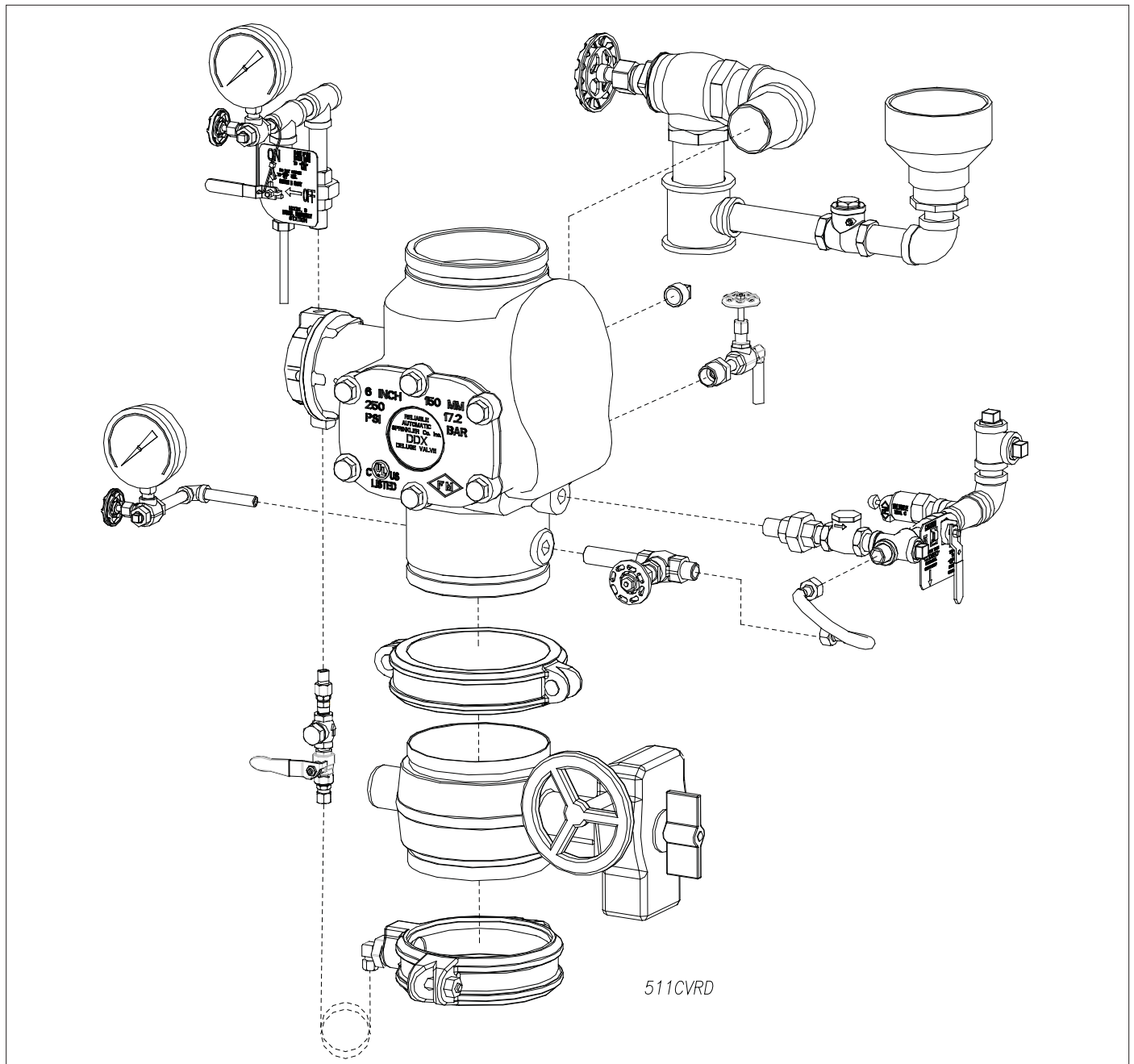

**Model DDX  
Deluge Valves  
4" (100mm), 6" (150mm)  
& 165mm Sizes**

# Instructions for Installation, Operation, Care and Maintenance

**Wet Pilot Line,  
Dry Pilot Line, and  
Electric Actuation Trims**



511CVRD

## General

The Reliable Model DDX Deluge Valve is a hydraulically operated, differential-type valve designed for use as primary control valve in deluge, preaction, or special types of fire protection systems. Following operation, the valve is easily reset externally (see Fig.1).

The Wet Pilot Line Trim set is connected to the push rod chamber outlet and provides a two-inch main drain, alarm test, supply pressure gauge, and the push rod chamber supply connections. This trim is needed for all applications. Releasing devices that can be used are wet pilot line detectors (Model F1-FTR) or hydraulic manual emergency stations/pull boxes (Models A & B).

Two alternate actuation trim sets, Dry Pilot Line or Electric Actuation, are available when dry pilot sprinklers or solenoid valves are used for releasing. Actuation by solenoid valves enables a full range of electrical detectors to be used for remote sensing.

## Listings & Approvals

(Only when used with Reliable's Trim Sets.)

1. Listed by Underwriters Laboratories, Inc. and UL certified for Canada (cULus).
2. Certified by Factory Mutual Approvals (FM).
3. NYC MEA 258-93-E.

## Valve Operation

The Reliable Model DDX Deluge Valve is shown in both closed and open positions in Fig. 1. In the closed position, the supply pressure acts on the underside of the clapper and also on the push rod through the push rod chamber's inlet restriction. The resultant force due to the supply pressure acting on the push rod is multiplied by the mechanical advantage of the lever and is more than sufficient to hold the clapper closed against normal supply pressure surges.

When a fire is detected, a releasing device vents the push rod chamber to atmosphere through the chamber's outlet. Since the pressure cannot be replenished through the inlet restriction as rapidly as it is vented, the push rod chamber pressure falls instantaneously. When the push rod chamber pressure approaches approximately one-third of the supply pressure, the upward force of the supply pressure acting beneath the clapper overcomes the lever-applied force thereby opening the clapper.

Once the clapper has opened, the lever acts as a latch, preventing the clapper from returning to the closed position. Water from the supply flows through the Deluge Valve into the system piping. Water also flows through the Deluge Valve alarm outlet to the alarm devices.

After system shutdown, resetting the Model DDX Deluge Valve is quite simple. Doing so only requires pushing in and turning the reset knob at the rear of the valve (see Fig.1). The external reset feature of the Model DDX Deluge Valve provides a means for simple, economical system testing, which is one essential facet of a good maintenance program. The external reset feature does not, however, eliminate another important facet of good maintenance, namely, periodic cleaning and inspection of the internal valve parts.

In the event that water builds up inside the valve due to condensate from the air supply system or water left inside from valve system testing, a drain is available for venting. After closing the main supply valve, a small valve over the drain cup can

be opened slightly until the water inside the valve body and the main pipe column has drained.

Whenever ambient temperature conditions are high, the water temperature in the Model DDX Deluge Valve's pushrod chamber could possibly increase, thereby increasing the pressure in the chamber to values exceeding the rated pressure of the system. In an indoor installation where standard room temperatures are exceeded, a pressure relief kit may be needed. Pressure relief kit, P/N 6503050001, can be installed into the pushrod chamber's release line to limit the pressure to 175 psi (12,1 bar).

Reliable Model DDX Deluge Valves with associated trim sizes 4" (100 mm), 6" (150mm) and 165mm, are rated for use at a minimum water supply pressure of 20 psi (1,4 bar) and a maximum water supply pressure of 250 psi (17,2 bar). Water supplied to the inlet of the valve and to the push rod chamber must be maintained between 40 °F (4 °C) and 140 °F (60 °C).

## Pressurizing Line Connection

The water supply for the push-rod chamber must be provided by connection of its inlet pressurizing line to the water supply piping. Pressurizing lines for multiple Model DDX Deluge Valve push-rod chambers must never be manifolded together, having only a single tap on the water supply piping. Each Model DDX Deluge Valve must have its own push-rod chamber pressurizing line connection. This connection must be made on the supply side of the water supply control valve (see Fig.3). This can be accomplished by:

- Using a tapped connection directly below or next to the main water supply control valve using a welded outlet or the appropriate mechanical fittings. A grooved-end outlet coupling is one way to achieve this (see Fig.3); or
- Using a water supply control valve that has an available threaded (NPT) supply-side tap design to allow for a direct water supply connection to the Model DDX Deluge Valve's push-rod chamber.

**Caution:** Reliable's DDX valve is designed with an inlet restriction built into the pushrod chamber. It is important not to introduce additional restrictions into the direct water supply connection or the discharge from the pushrod chamber by installing additional valves or improperly installing the copper lines used in the trim of the valve.

## Hydrostatic Testing of DDX Valves and DDX Systems

As required by NFPA 13, fire sprinkler systems with working pressures up to and including 150 psi are to be hydrostatically tested at a water pressure of 200 psi and maintain that pressure without loss for two hours. Fire sprinkler systems with working pressures above 150 psi are required to be hydrostatically tested at 50 psi above the system working pressure and maintain that pressure without loss for two hours. In addition to the hydrostatic tests described above, dry pipe and double interlock preaction systems require an additional low pressure air test.

In some cases, hydrostatic testing (in accordance with the NFPA 13 requirements noted above) will result in pressures that exceed the working pressure of the valve and trim kit for the two-hour test period. The valve and applicable trim kit have been tested, approved and listed under these conditions and as such, hydrostatic testing in accordance with NFPA 13 is acceptable.

DDX-LP VALVE CLAPPER IN "OPEN",  
"CLOSED" AND "LATCHED" POSITIONS

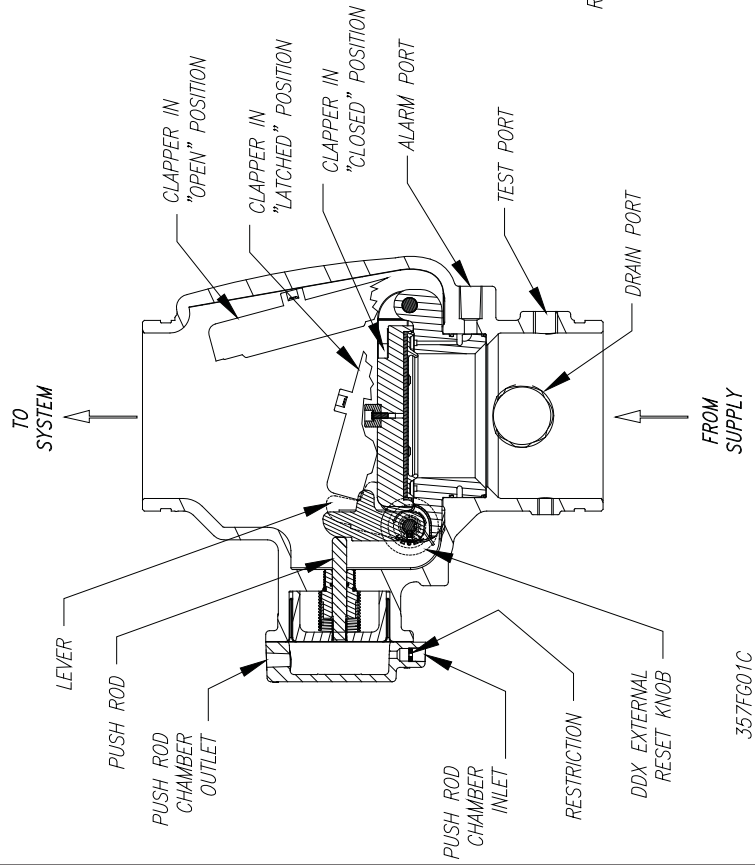

REAR VIEW OF MODEL  
DDX-LP DRY VALVE

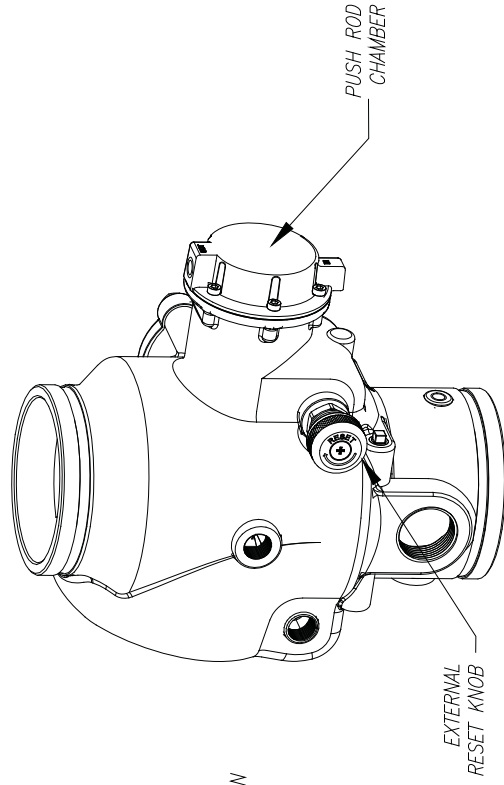

Fig. 1

In addition, the clapper can remain in the closed position and the trim kit need not be isolated, as each has been designed to withstand hydrostatic testing as required by NFPA 13.

Hydrostatically testing the valve and trim to pressures higher than their rating is limited to the hydrostatic test as referenced by NFPA 13. It does not address the occurrence(s) of a “water hammer” effect, which can indeed damage the valve. A “water hammer” in the water supply piping of the valve can create pressures in excess of the rated pressure and should be avoided by all necessary means. This condition may be created from improper fire pump settings, underground construction work, or an improper venting of trapped air in the water supply piping.

## **Engineering Specifications**

4” (100 mm), 6” (150 mm) and 165 mm

### **Model DDX Deluge Valves**

Deluge valve shall be a [4” (100 mm)] [6” (150 mm)] [cULus Listed] [Factory Mutual Approved] [New York City MEA Approved 258-93-E] hydraulically operated, differential latching clapper-type valve. Deluge valve construction shall be of light-weight, ductile-iron construction with “drop in” bronze seat and clapper assembly. Bronze seat shall have O-ring seals to resist corrosion and leakage. Clapper facing shall be pressure actuated, providing a limited compression seat for the sealing force between the clapper rubber facing and the valve seat. Deluge valve shall have an external reset knob for resetting the clapper without having to remove the valve face plate. Push-rod chamber design shall consist of a stainless steel piston/push-rod and spring assembly with diaphragm seal secured to the casting through a push-rod guide constructed of a synthetic engineering plastic to resist corrosion. Casting shall have a bleeder hole located on the push-rod chamber for air/water leakage indication. Trip ratio shall be approximately a 3:1 force differential. Deluge valve shall be of the straight-through design to minimize friction loss. Deluge valve shall be activated by [hydraulic wet-pilot] [low pressure, pneumatic dry-pilot] [electric] actuation trim. Inlet restriction orifice shall be factory installed into inlet port of deluge valve push-rod cover plate and not be a separate part of the deluge valve trim. End connection style to be [4” (100 mm) or 6” (150 mm)] grooved inlet and grooved outlet, per ANSI/AWWA C606. Deluge valve shall have a rated working pressure of 250 psi (17.2 bar) and shall be factory hydrostatic tested at 500 psi (34.5 bar). Deluge valve to be [4” (100 mm)] [6” (150 mm)] Reliable Model DDX Deluge Valve (Bulletin 511).

### **Wet Pilot Line Trim**

Deluge valve wet pilot line trim shall be galvanized and include 2” main drain, alarm line test, water pressure gauges, push rod chamber supply connections, manual emergency release valve, connection for the wet pilot line of detectors, and 4” diameter drip cup assembly. Condensate drain trim shall also be included to prevent water columning above the clapper. The

wet pilot line detection piping shall be ½” Schedule 40 galvanized pipe and extend from the deluge valve push rod chamber outlet to the protected area. Maximum wet pilot line length and height shall be in accordance with manufacturer’s guidelines. The wet pilot line shall utilize Reliable Model F1-FTR fixed temperature release pilot line detectors spaced and positioned in accordance with the device listing or in accordance with NFPA 72 as fixed temperature heat detectors.

### **Dry Pilot Line Trim**

Dry pilot trim is to be used in areas:

- Where ambient temperatures are expected to exceed 150 °F (65 °C)
- Subject to freezing
- Maximum pilot line height and length are exceeded

Deluge valve dry pilot line trim shall be galvanized and include Model LP Dry Pilot Line Actuator, 2” main drain, alarm line test, air and water pressure gauges, push rod chamber supply connections, manual emergency release valve, pressure relief valve, low air pressure switch, connections for the dry pilot line of detectors and 4” diameter drip cup assembly. Condensate drain trim shall also be included to prevent water columning above the clapper. The dry pilot line detection piping shall be ½” Schedule 40 galvanized pipe and extend from the deluge valve push rod chamber outlet to the protected area. The dry pilot line shall utilize Reliable Model F1-FTR fixed temperature release pilot line detectors spaced and positioned in accordance with the device listing or in accordance with NFPA 72 as fixed temperature heat detectors.

### **Electric Actuation Trim**

Deluge valve electric trim shall be galvanized and include a normally closed, powered open electric solenoid valve, 2” main drain, alarm line test, water pressure gauges, push rod chamber supply connections, manual emergency release valve, and 4” diameter drip cup assembly. Condensate drain trim shall also be included to prevent water columning above the clapper.

### **Solenoid Valve Specifications:**

Skinner Model 73218BN4UNLVN0C111C2

Rated working pressure (specify): 175 (12,1 bar) or 250 psi (17,2 bar)

Voltage: 24 VDC

Watts: 10

Current: .42 A Holding

Enclosure Coil: NEMA 4X

Pipe Size: ½” NPT Female

Cv Factor: 4.0

## Model DDX-LP Dry Pipe Valve Description

- Rated working pressure:  
Valve & System - 250 psi (17,2 bar)
- Factory tested to a hydrostatic pressure of 500 psi (34,5 bar). (Valve only)
- End and trim connections:
  - ANSI/AWWA C606 grooved inlet and outlet

Groove Dimensions				
Valve Size	Outlet Diameter	Groove Diameter	Groove Width	Outlet Face to Groove
4" (100mm)	4.500" (114mm)	4.334" (110mm)	$\frac{3}{8}$ " (10mm)	$\frac{5}{8}$ " (16mm)
6" (150mm)	6.625" (168mm)	6.455" (164mm)		
165mm	6.500" (165mm)	6.330" (161mm)		

- Threaded openings Per ANSI B 2.1
- Valve exterior's color:

Valve Size	Color
4" (100 mm) 6" (150 mm)	Black
165 mm	Red

- Face to face dimensions:
  - 4"(100 mm) — 14" (355 mm)
  - 6"(150 mm) & 165 mm — 16" (406 mm)
- Shipping weight:

Valve Size	Weight
4" (100 mm)	64 lb. (29 kg)
6" (150 mm) & 165mm	95 lb. (43 kg)

- Friction loss (Expressed in equivalent length of Schedule 40 pipe, based on Hazen & Williams formula with C=120 and a flow velocity of 15ft/sec (4.6 m/sec)):

Valve Size	Equivalent Length
4" (100mm)	14' (4.27 m)
6" (150mm) & 165mm	29.4' (9 m)

- Installation position: Vertical

## Trim Descriptions

The trims for the Reliable Models DDX Deluge Valves are arranged for rapid, easy, and compact attachment and serve as connection points to Reliable Model C Mechanical Alarms and other devices.

The available Model DDX Deluge Valve trim sets are:

- Wet Pilot Line Trim
- Dry Pilot Line Trim
- Electric Actuation Line Trim

All three trim configurations can be ordered as individual parts, in time-saving segmentally assembled kit forms, or fully assembled to the Model DDX Deluge Valve (with or without a control valve).

The Model B Hydraulic Manual Emergency Station (see Fig. 7) is a standard item of all Deluge Valve trim sets. It consists of an aluminum nameplate mechanically attached to a ball valve. The valve handle in its OFF position is guarded against accidental turning to the ON position (and system discharge) by a nylon cable tie provided with each trim kit. The cable tie is inserted, as shown in Fig. 7, after the system has been restored for operation. The nylon cable tie is designed to allow, in case of an emergency, forceful turning of the valve handle to the ON position. As an alternative to the Model B Hydraulic Manual Emergency Station, the Model A Hydraulic Manual Emergency Pull Box (see Bulletin 506) is also available and can be provided as an option.

Model F1-FTR fixed temperature pilot line detectors and spacing requirements are described in Bulletin 180.

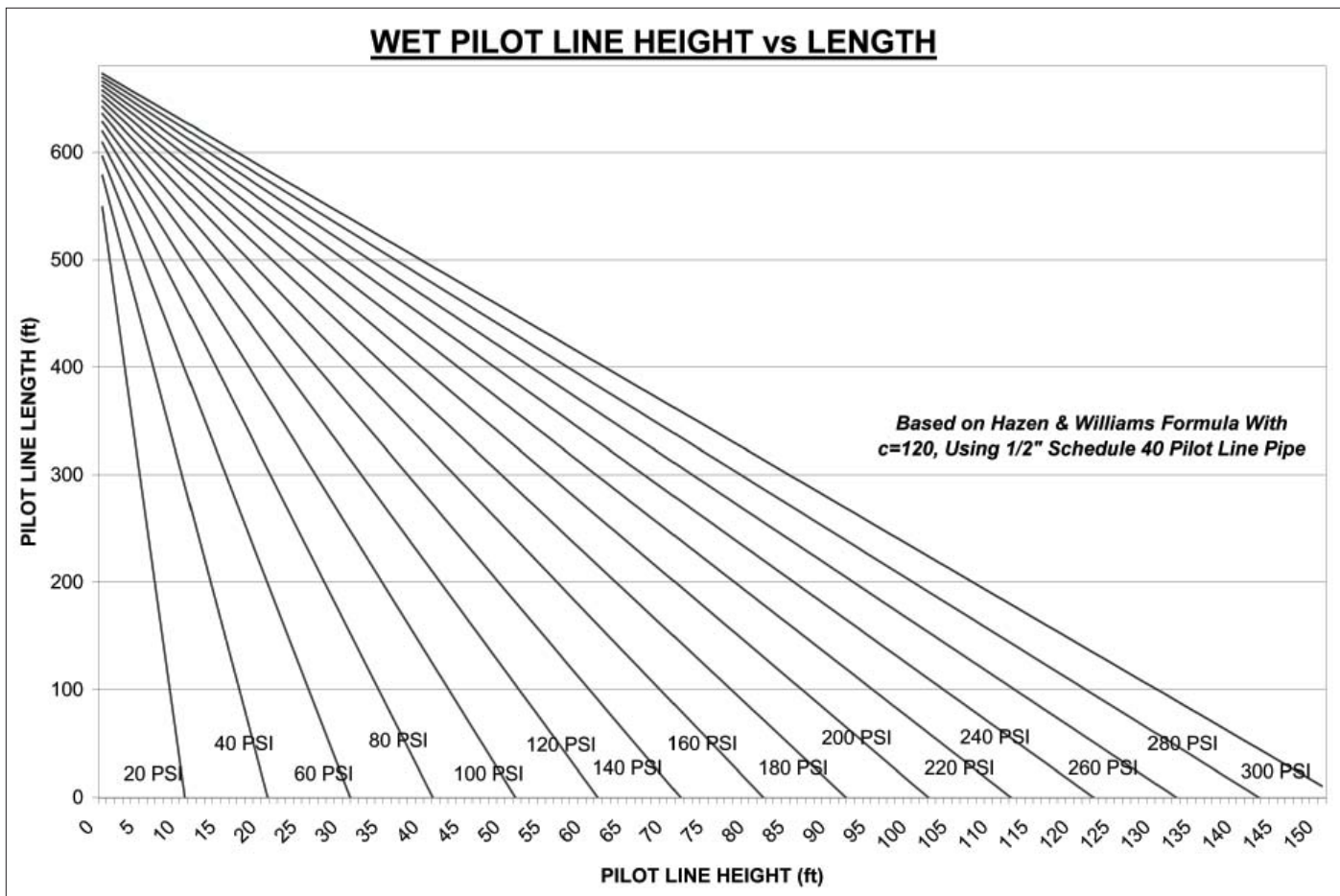

Fig. 2

### Wet Pilot Line Trim

Wet pilot line operation is the simplest method of Deluge Valve actuation. The trim is a basic one and is required on all Reliable Model DDX Deluge Valves regardless of application. Shown in Fig. 3, it contains components required on all installations, such as two-inch main drain, alarm test, supply and push rod chamber pressure gauges, and push rod chamber connections. The wet pilot line consists of a line of closed detectors (Model F1-FTR) located over the area to be protected. This line contains water under pressure and is connected to the outlet of the push rod chamber of the Deluge Valve. When one of the pilot line detectors actuates, the push rod chamber is vented and the Deluge Valve operates. The Deluge Valve can also be operated manually by opening the ball valve of the Model B Hydraulic Manual Emergency Station (see Fig. 7) or the optional Model A Hydraulic Manual Emergency Pull Box (see Reliable Bulletin 506).

The wet pilot line is only a detection system and does not contribute to controlling the fire. Its installation is subject to the following restrictions:

- a) It is not to be installed in an area subject to freezing.
- b) It is not to be installed in an area where temperatures in excess of 150°F (65°C) are anticipated.
- c) NFPA 72 or the authority having jurisdiction should be consulted for spacing and elevation requirements.
- d) Maximum wet pilot line length and height must comply with data provided in Fig. 2.

Wet Pilot Trim installation on Model DDX Deluge Valves uses eight tapped openings for trim connections. Each opening and its function are indicated on Fig. 3. Using Fig. 3 as reference, the recommended trim installation is as follows:

1. Install 1/2" nipple (#30) in the tapped opening marked "TEST".
2. Install 1/2" nipple (#28) in the tapped opening marked "ALARM" and connect balance of this trim line.
3. Install 1/4" nipple (#35) in the tapped opening marked "SUPPLY" and connect balance of this trim line.
4. Install 1/2" nipple (#28) in the tapped opening marked "OUT" and connect balance of this trim line.
5. Install 1/4" check valve (#57) in the tapped opening marked "IN" and connect balance of this trim line.
6. Install 2" nipple (#36) in the tapped drain opening and connect balance of this trim line.
7. Install 3/4" X 1/4" reducing bushing (#9) in the lower-most tapped opening at the rear of the Deluge Valve and connect the balance of this trim line.
8. Install 3/4" pipe plug (#43) in the upper-most tapped opening at the rear of the Deluge Valve.

**Deluge Valve Wet Pilot Line Trim Parts List (Refer to Fig. 3)**

Item No.	Part Number	Description	No. Req'd
1	6103060024	Assembly, Valve, 6" (150mm) For 6" Ass'y Only	1
	6103040026	Assembly, Valve, 4" (100mm) For 4" Ass'y Only	
2	6215052400	Wafer-Butterfly Valve, 6" For 6" Ass'y Only	1
	6215051600	Wafer-Butterfly Valve, 4" For 4" Ass'y Only	
3	7G05242400	Coupling, Rigid, 6" For 6" Ass'y Only	1
	7G05161600	Coupling, Rigid, 4" For 4" Ass'y Only	
4	7D05464200	Coupling, Rigid, 6" W/1" Outlet For 6" Ass'y Only	1
	7D05444400	Coupling, Rigid, 4" W/3/4" Outlet For 4" Ass'y Only	
5	98048028	Bushing, Reducer, 1" X 1/4", Galv. For 6" Ass'y Only	1
	98048025	Bushing, Reducer, 3/4" X 1/4", Galv. For 4" Ass'y Only	
6	78653000	Assembly, Manual Emergency Station	1
7	78653004	Assembly, Valve Caution Station, 1/2"	1
8	98048015	Bushing, Reducer, 2" Spigot X 1" Nptf, Pvc	1
9	98048025	Bushing, Reducer, 3/4" X 1/4", Galv.	1
10	92056810	Connector, 3/8" ID Tubing X 1/2" Npt	1
11	98840147	Check Valve, 1/4" Npt, Poppet Type Inline	1
12	92056702	Connector, 3/8" ID Tubing X 1/4" Npt	1
13	92056705	Connector, Elbow, 3/8" ID Tubing X 1/4" Npt	1
14	98050004	Drain Cup, Pvc	1
15	92056703	Elbow, Male, 3/8" Tube X 1/4 Npt	1
16	98174403	Eil, 1", Mall Iron, Galv.	1
17	98174404	Eil, 1/4", Mall Iron, Galv.	1
18	98174405	Eil, 2", Mall Iron, Galv.	1
19	98174402	Eil, 3/4", Mall Iron, Galv.	1
20	96920912	Flex Line, 12"	1
21	98248001	Gauge, Water Pressure (0-300 Psi)	2
22	98840172	Globe Valve, 1/4"	1
23	98840181	Horiz. Swing Check Valve, 1/2" Npt	1
24	94616915	Nameplate, Deluge Valve	1

Item No.	Part Number	Description	No. Req'd
25	98543222	Nipple, Steel, Galv., 1" X 3-1/2"	1
26	98543266	Nipple, Steel, Galv., 1" X 6"	1
27	98543213	Nipple, Steel, Galv., 1" X Close	1
28	98543223	Nipple, Steel, Galv., 1/2" X 1-1/2"	7
29	98543210	Nipple, Steel, Galv., 1/2" X 2-1/2"	2
30	98543228	Nipple, Steel, Galv., 1/2" X 4-1/2"	1
31	98543209	Nipple, Steel, Galv., 1/2" X 2"	2
32	98543230	Nipple, Steel, Galv., 1/2" X 3"	1
33	98543226	Nipple, Steel, Galv., 1/4" X 1-1/2"	1
34	98543244	Nipple, Steel, Galv., 1/4" X 2"	1
35	98543220	Nipple, Steel, Galv., 1/4" X 3"	2
36	98543208	Nipple, Steel, Galv., 2" X 3"	2
37	98543238	Nipple, Steel, Galv., 2" X Close	1
38	98543279	Nipple, Steel, Galv., 3/4" X Close	2
39	99080002	Pad-adhesive	1
40	98750003	Pipe Cross, 1/2", Galv.	1
41	98604406	Plug, Iron, Sq. Hd., 1/2"	1
42	98614403	Plug, Iron, Sq. Hd., 1/4"	2
43	98614401	Plug, Iron, Sq. Hd., 3/4"	3
44	98727607	Strainer, 1/4"	1
45	98840145	Swing Check Valve, 1" Npt	1
46	96606627	Tee, Glvn, 2" X 2" X 1"	1
47	89141112	Tie, Retaining	9
48	98761649	Tee, Glvn., 1/2" X 1/4" X 1/2"	1
49	98761651	Tee, Glvn., 1/2"	1
50	96606612	Tee, Glvn., 3/4" X 1/2" X 1/2"	1
51	96606601	Tee, Glvn., 3/4"	1
52	98815200	Union, 1/2", Iron, Galv.	2
53	98840160	Valve, 3-way, 1/4"	2
54	98840100	Valve, Angle, 2"	1
55	78653100	Valve, Ball Drip, 1/2"	1
56	98840117	Valve, Ball, 1/4" Nptf X 1/4" Nptm	1
57	98840187	Valve, Check, 1/4" Nptf X 1/4" Nptm	1
58	98840171	Valve, Globe, 1/2"	1
59	----	----	--
60	96686756	Tubing, Pvc, 3/8" ID X 6 Ft.	1
61	98768008	Copper Tubing, 3/8"	30"

# WET PILOT LINE DELUGE TRIM

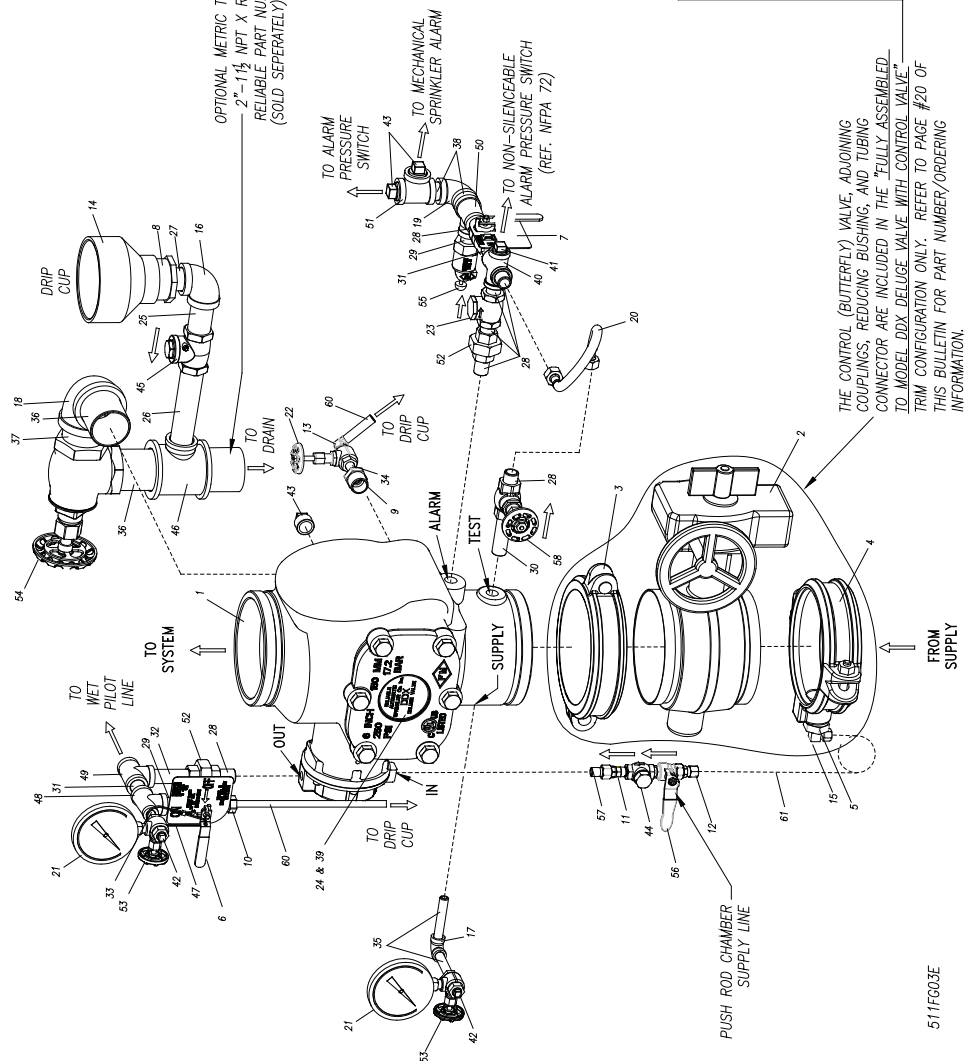

OPTIONAL METRIC THREAD ADAPTER NIPPLE.  
2"-1 1/4" NPT X R2, ISO 7/11 X CLOSE  
RELIABLE PART NUMBER 985643401  
(SOLD SEPARATELY)

RECOMMENDED INSTALLATION LOCATION FOR A FIRE DEPT.  
CONNECTION (FDC) IS ABOVE THE MODEL DDX DELUGE VALVE.

- AVAILABLE TRIM CONFIGURATIONS:
- 1) INDIVIDUAL PARTS (MODEL DDX DELUGE VALVE SOLD SEPARATELY)
  - 2) SEGMENTALLY ASSEMBLED (MODEL DDX DELUGE VALVE SOLD SEPARATELY)
  - \*3) FULLY ASSEMBLED TO MODEL DDX DELUGE VALVE WITH CONTROL VALVE
  - 4) FULLY ASSEMBLED TO MODEL DDX DELUGE VALVE WITHOUT CONTROL VALVE

ALL STEEL COMPONENTS OF THE TRIM ASSEMBLIES ARE GALVANIZED

THE CONTROL (BUTTERFLY) VALVE, ADJOINING COUPLINGS, REDUCING BUSHING, AND TUBING CONNECTOR ARE INCLUDED IN THE "FULLY ASSEMBLED TO MODEL DDX DELUGE VALVE WITH CONTROL VALVE" TRIM CONFIGURATION ONLY. REFER TO PAGE #20 OF THIS BULLETIN FOR PART NUMBER/ORDERING INFORMATION.

511F003E

Fig. 3

## Dry Pilot Line Trim

Dry pilot line operation is used in areas which are subject to freezing conditions or to obtain installed sprinkler heights and pipe lengths greater than allowed for wet pilot line trim. Dry pilot operation uses a pilot line of closed sprinklers (Model F1-FTR) containing air under pressure located in the area to be protected. This pressurized line is connected to a Model LP Dry Pilot Line Actuator. The dry pilot line actuator functions very much like a miniature dry pipe valve. In areas where moisture-laden air could cause freezing or other problems in the dry pilot line, the use of a cylinder of dry compressed gas such as nitrogen is suggested. Approved gas handling regulators and connections are then recommended. When one of the closed sprinklers on the dry pilot line actuates, the air pressure is reduced, thus opening the Model LP Dry Pilot Line Actuator, which releases the Deluge Valve. NFPA 72 or the Authority Having Jurisdiction should be consulted for spacing and elevation requirements of the pilot line sprinklers.

The Dry Pilot Line Trim, shown in Fig. 5, includes gauges to read both the air and water pressure, a low air pressure switch, a pressure relief valve, a Model LP Dry Pilot Line Actuator, and connections for the dry pilot line of detectors.

Dry Pilot Line Trim installation on Model DDX Deluge Valves uses eight tapped openings for trim connections. Each opening and its function are indicated on Fig. 5. Using Fig. 5 as reference, the recommended trim installation is as follows:

1. Install ½" nipple (#37) in tapped opening marked "TEST".
2. Install ½" nipple (#35) in tapped opening marked "ALARM" and connect balance of this trim line.
3. Install ¼" nipple (#42) in tapped opening marked "SUPPLY" and connect balance of this trim line.
4. Install ½" nipple (#35) in tapped opening marked "OUT" and connect balance of this trim line.
5. Install ¼" check valve (#65) in tapped opening marked "IN" and connect balance of this trim line.
6. Install 2" nipple (#43) in tapped drain opening and connect balance of this trim line.
7. Install ¾" x 1/4" reducing bushing (#12) in the lower-most tapped opening at the rear of the Deluge Valve and connect the balance of this trim line.
8. Install ¾" pipe plug (#50) in the upper-most tapped opening at the rear of the Deluge Valve.

Connect the air supply to the air inlet side of the Model LP Dry Pilot Line Actuator as shown in Fig. 5. Table A specifies the air pressure to be used in a dry pilot line. The level of air pressure is adjusted by removing the cap nut on the end of the Relief Valve (#55 Fig. 5) and turning the now exposed slotted adjusting screw clockwise to increase pressure or counterclockwise to reduce it. Replace the cap nut after the correct pressure setting has been made at 5 psi above the maximum pilot line pressure required by Table A. An appropriate automatic pressure maintenance device must be used to safeguard against the Deluge Valve tripping due to air pressure leaks in the dry pilot line. See Bulletins 250 and 251 for pressure maintenance device information. Install the dry pilot line as required. Wire the low air pressure switch (#36, Fig. 5) to an annunciating device or control panel. This low air pressure switch should be set to open at an air pressure which is slightly lower than the "Not Less Than" values found in Table A.

**Table A**

Water Pressure psi (bar)	Pneumatic Pressure to be Pumped into Sprinkler System, psi (bar)	
	Maximum	Not Less Than
20 (1,4)	10 (0,7)	14 (0,9)
50 (3,4)	12 (0,8)	16 (1,1)
75 (5,2)	13 (0,9)	17 (1,2)
100 (6,9)	15 (1,0)	19 (1,3)
125 (8,6)	16 (1,1)	20 (1,4)
150 (10,3)	17 (1,2)	21 (1,4)
175 (12,0)	18 (1,2)	22 (1,5)
200 (13,8)	19 (1,2)	23 (1,6)
225 (15,5)	21 (1,5)	25 (1,7)
250 (17,2)	22 (1,5)	26 (1,8)

**Note:** During system set-up, a higher pneumatic pressure may be required in order to properly set the Model LP Dry Pilot Line Actuator.

## MODEL LP DRY PILOT LINE ACTUATOR

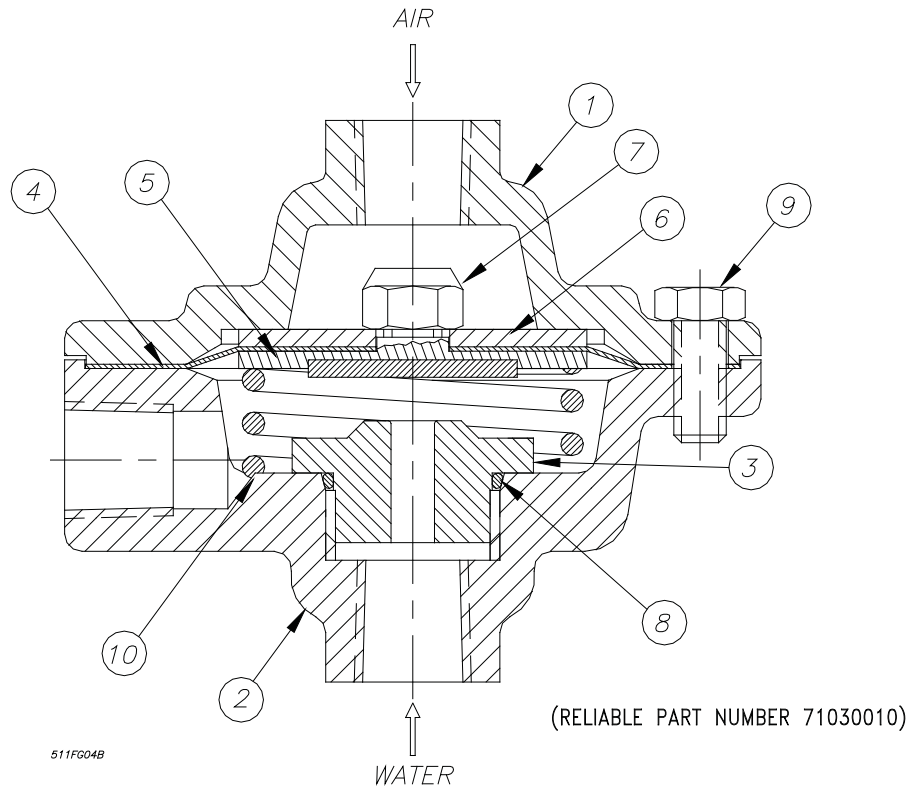

Fig. 4

### Model LP Dry Pilot Line Actuator Parts List P/N 71030010

Item No.	Part No.	Description	Qty. Required
1	94106936	Lower Housing	1
2	94106935	Upper Housing	1
3	96006905	Seat	1
4	92206311	Diaphragm	1
5	95106911	Facing Plate Assembly	1
6	96906311	Diaphragm Washer	1
7	94906406	Facing Plate Nut	1
8	95406901	Seat O-Ring	1
9	95606305	Bolt	6
10	96406902	Compression Spring	1

### Maintenance – Model LP Dry Pilot Line Actuator

Refer to Figs. 4 & 9

If water constantly flows through the Model LP Dry Pilot Line Actuator and into the drain, there is a leak in the seal of the Actuator's seat.

1. Close the main valve controlling water supply (Fig. 9) to the Dry Pipe Valve and close off the air/nitrogen supply to the sprinkler system. Close valve A (Fig. 9).
2. Drop pressure in the system by opening the ¼" angle valve, valve H (Fig. 9), and remove the Actuator from the system.
3. Remove all six bolts (#9, Fig. 4) holding the Actuator together. Clean or replace the facing plate assembly (#5, Fig. 4) and seat (#3, Fig. 4).
4. Reassemble the Actuator, using a torque of 8 ft-lbs on the facing plate nut (#7, Fig. 4) and 12 ft-lbs on the six bolts (#9, Fig. 4). Use a cross-tightening pattern. Reinstall the Actuator. Set up the Model DDX Deluge Valve as per the section "Resetting Model DDX Deluge Valve System".

Item No.	Part No.	Description	No. Req'd
1	6103060024	Assembly, Valve, 6" (150mm) For 6" Ass'y Only	1
	6103040026	Assembly, Valve, 4" (100mm) For 4" Ass'y Only	
2	6215052400	Waffer-butterfly Valve, 6" For 6" Ass'y Only	1
	6215051600	Waffer-butterfly Valve, 4" For 4" Ass'y Only	
3	7G05242400	Coupling, Rigid, 6" For 6" Ass'y Only	1
	7G05161600	Coupling, Rigid, 4" For 4" Ass'y Only	
4	7D05464200	Coupling, Rigid, 6" W/1" Outlet For 6" Ass'y Only	1
	7D05444200	Coupling, Rigid, 4" W/3/4" Npt Outlet For 4" Ass'y Only	
5	98048028	Bushing, Reducer, 1" X 1/4", Galv. For 6" Ass'y Only	1
	98048025	Bushing, Reducer, 3/4" X 1/4", Galv. For 4" Ass'y Only	
6	6999991340	Pressure Switch, Eps40-2 (UL/FM)	1
	6999992361	Pressure Switch, Epsa40-2 (ULC)	
7	78653000	Assembly, Manual Emergency Station	1
8	78653004	Assembly, Valve Caution Station, 1/2"	1
9	98048015	Bushing, Reducer, 2" Spigot X 1" Nptf, Pvc	1
10	98048022	Bushing, Reducer, 3/4" X 1/2", Galv.	1
11	98048000	Bushing, Reducer, 1/2" X 1/4", Galv.	1
12	98048025	Bushing, Reducer, 3/4" X 1/4", Galv.	1
13	98840147	Check Valve, 1/4" Npt, Poppet Type Inline	1
14	92056810	Connector, 3/8" ID Tube X 1/2" Npt	1
15	92056704	Connector, Elbow, 3/8" ID Tube X 1/2" Npt	1
16	92056702	Connector, 3/8" Tubing X 1/4" Npt	1
17	92056705	Connector, Elbow, 3/8" ID Tube X 1/4" Npt	1
18	98050004	Drain Cup, Pvc	1
19	92056703	Elbow, Male, 3/8" ID Tube X 1/4 Npt	1
20	98174401	Eil, 1/2", Mall Iron, Galv.	1
21	98174403	Eil, 1", Mall Iron, Galv.	1
22	98174404	Eil, 1/4", Mall Iron, Galv.	1
23	98174405	Eil, 2", Mall Iron, Galv.	1
24	98174402	Eil, 3/4", Mall Iron, Galv.	1
25	96920912	Flex Line, 12"	1
26	98248000	Gauge, Air Pressure (0-80 Psi)	1

Item No.	Part No.	Description	No. Req'd
27	98248001	Gauge, Water Pressure (0-300 Psi)	2
28	98840172	Globe Valve, 1/4"	1
29	98840181	Horiz. Swing Check Valve, 1/2" Npt	1
30	71030010	Model Lp Pilot Line Actuator	1
31	94616915	Nameplate, Deluge Valve	1
32	98543222	Nipple, Steel, Galv., 1" X 3-1/2"	1
33	98543266	Nipple, Steel, Galv., 1" X 6"	1
34	98543213	Nipple, Steel, Galv., 1" X Close	1
35	98543223	Nipple, Steel, Galv., 1/2" X 1-1/2"	14
36	98543210	Nipple, Steel, Galv., 1/2" X 2-1/2"	2
37	98543228	Nipple, Steel, Galv., 1/2" X 4-1/2"	1
38	98543209	Nipple, Steel, Galv., 1/2" X 2"	2
39	98543230	Nipple, Steel, Galv., 1/2" X 3"	2
40	98543226	Nipple, Steel, Galv., 1/4" X 1-1/2"	1
41	98543244	Nipple, Steel, Galv., 1/4" X 2"	1
42	98543220	Nipple, Steel, Galv., 1/4" X 3"	3
43	98543208	Nipple, Steel, Galv., 2" X 3"	2
44	98543238	Nipple, Steel, Galv., 2" X Close	1
45	98543279	Nipple, Steel, Galv., 3/4" X Close	2
46	99080002	Pad-adhesive	1
47	98750003	Pipe Cross, 1/2", Galv.	2
48	98604406	Plug, Iron, Sq. Hd., 1/2"	2
49	98614403	Plug, Iron, Sq. Hd., 1/4"	3
50	98614401	Plug, Iron, Sq. Hd., 3/4"	3
51	98727607	Strainer, 1/4"	1
52	98840145	Swing Check Valve, 1" Npt	1
53	96606627	Tee, Glvn, 2" X 2" X 1"	1
54	89141112	Tie, Retaining	9
55	98761649	Tee, Glvn., 1/2" X 1/4" X 1/2"	1
56	98761651	Tee, Glvn., 1/2"	3
57	96606612	Tee, Glvn., 3/4" X 1/2" X 1/2"	1
58	96606601	Tee, Glvn., 3/4"	1
59	98815200	Union, 1/2", Iron, Galv.	3
60	98840160	Valve, 3-way, 1/4"	3
61	98840100	Valve, Angle, 2"	1
62	78653100	Valve, Ball Drip, 1/2"	1
63	98840109	Valve, Ball, 1/2"	1
64	98840117	Valve, Ball, 1/4" Nptf X 1/4" Nptm	1
65	98840187	Valve, Check, 1/4" Nptf X 1/4" Nptm	1
66	98840171	Valve, Globe, 1/2"	1
67	98840195	Valve, Relief, 1/2", 33 Psi	1
68	----	----	--
69	96686756	Tubing, Pvc, 3/8" ID X 6 Ft.	1
70	98768008	Copper Tubing, 3/8"	30"



## Electric Actuation Trim

Electric Actuation trim (see Fig. 6) combines a normally-closed/powerd-open solenoid valve with the Wet Pilot Trim for releasing the Deluge Valve. The solenoid valve used in the assembly is available in both a 175 psi (12,1 bar) or 250 psi (17,2 bar) rating. Details on the electrical portion of this trim can be found in Reliable Bulletin 700, which describes Deluge and Preaction Systems.

**Caution:** Repairs or disassembly of the solenoid valve should only be done by a trained technician. An improperly repaired or partially assembled solenoid valve could result in failure of the valve to operate.

Electric Actuation Trim installation on Model DDX Deluge Valves uses eight tapped openings for trim connections. Each opening and its function are indicated on Fig. 6. Using Fig. 6 as reference, the recommended trim installation is as follows:

1. Install ½" nipple (#32) in tapped opening marked "TEST".
2. Install ½" nipple (#30) in tapped opening marked "ALARM" and connect balance of this trim line.
3. Install ¼" nipple (#37) in tapped opening marked "SUPPLY" and connect balance of this trim line.
4. Install ½" nipple (#30) in tapped opening marked "OUT" and connect balance of this trim line.
5. Install ¼" check valve (#59) in tapped opening marked "IN" and connect balance of this trim line. Supply line must be connected to the inlet of the control valve for each Deluge Valve as shown.
6. Install 2" nipple (#38) in tapped drain opening and connect balance of this trim line.
7. Install ¾" x 1/4" reducing bushing (#10) in the lower-most tapped opening at the rear of the Deluge Valve and connect the balance of this trim line.
8. Install ¾" pipe plug (#45) in the upper-most tapped opening at the rear of the Deluge Valve.

### Electric Actuation Trim Parts List (Refer to Fig. 6)

Item No.	Part No.	Description	Qty. Req'd
1	6103060024	Assembly, Valve, 6" For 6" Ass'y Only	1
	6103040026	Assembly, Valve, 4" For 4" Ass'y Only	
2	6215052400	Wafer-butterfly Valve, 6" For 6" Ass'y Only	1
	6215051600	Wafer-butterfly Valve, 4" For 4" Ass'y Only	
3	7g05242400	Coupling, Rigid, 6" For 6" Ass'y Only	1
	7g05161600	Coupling, Rigid, 4" For 4" Ass'y Only	
4	7d05464200	Coupling, 6" Grooved W/ 1" Npt Outlet For 6" Ass'y Only	1
	7d05444200	Coupling, 4" Grooved W/ 3/4" Npt Outlet For 4" Ass'y Only	
5	98048028	Bushing, Reducer, 1" X 1/4", Galv. For 6" Ass'y Only	1
	98048025	Bushing, Reducer, 3/4" X 1/4", Galv. For 4" Ass'y Only	
6	6871020000	Valve, Solenoid (175 Psi Rated)	1
	6871020020	Valve, Solenoid (250 Psi Rated)	

Item No.	Part No.	Description	Qty. Req'd
7	78653000	Assembly, Manual Emergency Station	1
8	78653004	Assembly, Valve Caution Station, 1/2"	1
9	98048015	Bushing, Reducer, 2" Spigot X 1" Nptf, Pvc	1
10	98048025	Bushing, Reducer, 3/4" X 1/4", Galv.	1
11	98840147	Check Valve, 1/4" Npt, Poppet Type Inline	1
12	92056702	Connector, 3/8" ID Tubing X 1/4" Npt	1
13	92056810	Connector, 3/8" ID Tubing X 1/2" Npt	1
14	92056704	Connector, Elbow, 3/8" ID Tubing X 1/2" Npt	1
15	92056705	Connector, Elbow, 3/8" ID Tubing X 1/4" Npt	1
16	98050004	Drain Cup, Pvc	1
17	92056703	Elbow, Male, 3/8" Tubing X 1/4 Npt	1
18	98174403	Ell, 1", Mall Iron, Galv.	1
19	98174404	Ell, 1/4", Mall Iron, Galv.	1
20	98174405	Ell, 2", Mall Iron, Galv.	1
21	98174402	Ell, 3/4", Mall Iron, Galv.	1
22	96920912	Flex Line, 12"	1
23	98248001	Gauge, Water Pressure (0-300 Psi)	2
24	98840172	Globe Valve, 1/4"	1
25	98840181	Horiz. Swing Check Valve, 1/2" Npt	1
26	94616915	Nameplate, Deluge Valve	1
27	98543222	Nipple, Steel, Galv., 1" X 3-1/2"	1
28	98543266	Nipple, Steel, Galv., 1" X 6"	1
29	98543213	Nipple, Steel, Galv., 1" X Close	1
30	98543223	Nipple, Steel, Galv., 1/2" X 1-1/2"	9
31	98543210	Nipple, Steel, Galv., 1/2" X 2-1/2"	1
32	98543228	Nipple, Steel, Galv., 1/2" X 4-1/2"	1
33	98543209	Nipple, Steel, Galv., 1/2" X 2"	2
34	98543230	Nipple, Steel, Galv., 1/2" X 3"	1
35	98543226	Nipple, Steel, Galv., 1/4" X 1-1/2"	1
36	98543244	Nipple, Steel, Galv., 1/4" X 2"	1
37	98543220	Nipple, Steel, Galv., 1/4" X 3"	2
38	98543208	Nipple, Steel, Galv., 2" X 3"	2
39	98543238	Nipple, Steel, Galv., 2" X Close	1
40	98543279	Nipple, Steel, Galv., 3/4" X Close	2
41	99080002	Pad-adhesive	1
42	98750003	Pipe Cross, 1/2", Galv.	1
43	98604406	Plug, Iron, Sq. Hd., 1/2"	1
44	98614403	Plug, Iron, Sq. Hd., 1/4"	2
45	98614401	Plug, Iron, Sq. Hd., 3/4"	3
46	98727607	Strainer, 1/4"	1
47	98840145	Swing Check Valve, 1" Npt	1
48	96606627	Tee, Glvn, 2" X 2" X 1"	1
49	89141112	Tie, Retaining	9
50	98761649	Tee, Glvn., 1/2" X 1/4" X 1/2"	1
51	98761651	Tee, Glvn., 1/2"	1
52	96606612	Tee, Glvn., 3/4" X 1/2" X 1/2"	1
53	96606601	Tee, Glvn., 3/4"	1
54	98815200	Union, 1/2", Iron, Galv.	2
55	98840160	Valve, 3-way, 1/4"	2
56	98840100	Valve, Angle, 2"	1
57	78653100	Valve, Ball Drip, 1/2"	1
58	98840117	Valve, Ball, 1/4" Nptf X 1/4" Nptm	1
59	98840187	Valve, Check, 1/4" Nptf X 1/4" Nptm	1
60	98840171	Valve, Globe, 1/2"	1
61	-----	-----	---
62	96686756	Tubing, Pvc, 3/8" ID X 6 Ft.	1
63	98768008	Copper Tubing, 3/8"	30"

TRIM IS AVAILABLE WITH 175 PSI (12.1 BAR) OR 250 PSI (17.2 BAR) RATED SOLENOID VALVE - 24 VDC, 10 WATTS, SKINNER (PARKER HANNIFIN CORP.) P/N 73218BN4UNLVNOC111C2, RELIABLE P/N 6871010000  
 250 PSI (17.2 BAR) RATED SOLENOID VALVE - 24 VDC, 22 WATTS, SKINNER (PARKER HANNIFIN CORP.) P/N 73212BN4UNLVNOC322C2, RELIABLE P/N 6871010020

# ELECTRIC ACTUATION DELUGE TRIM

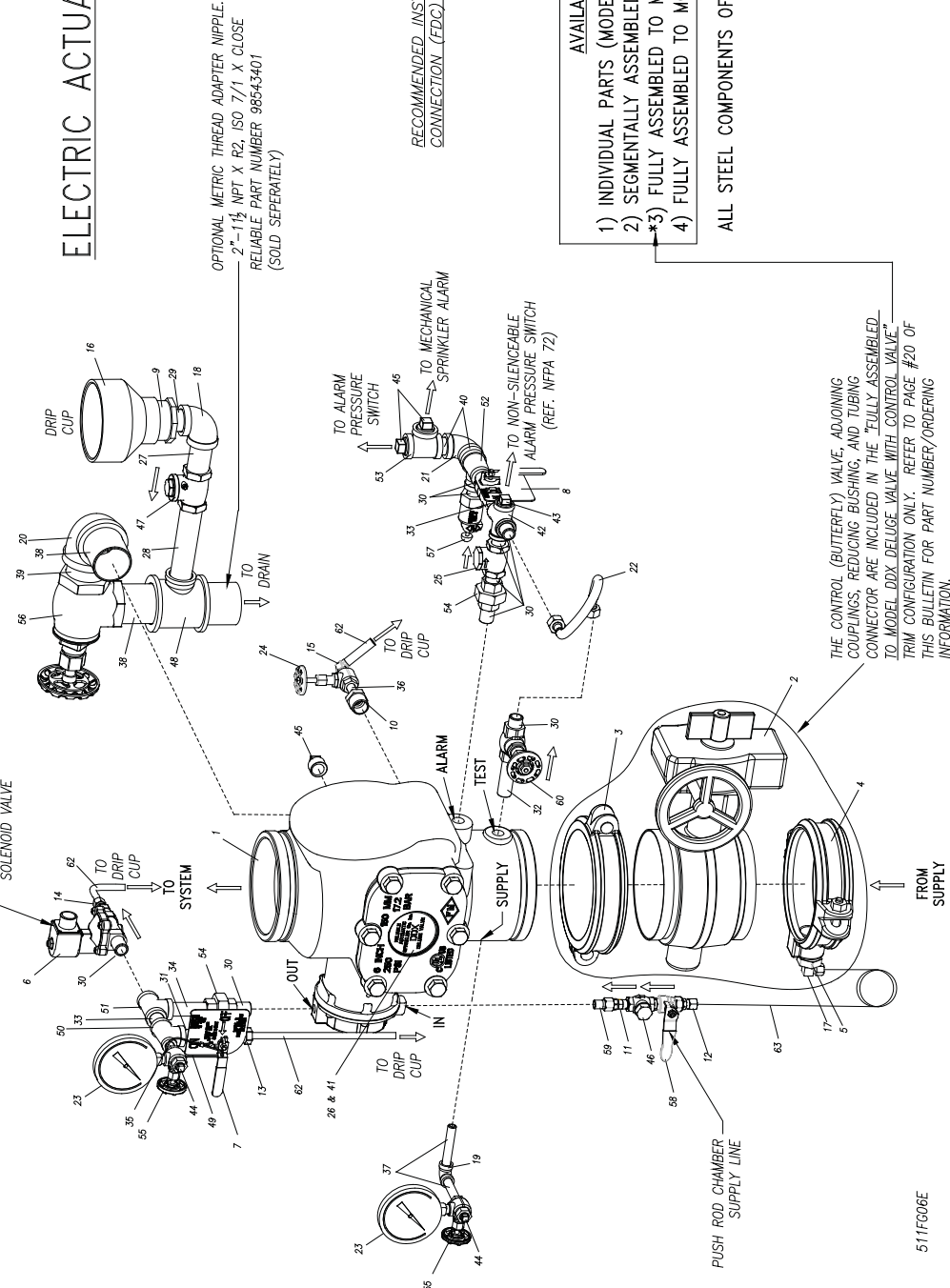

- AVAILABLE TRIM CONFIGURATIONS:
- 1) INDIVIDUAL PARTS (MODEL DDX DELUGE VALVE SOLD SEPARATELY)
  - 2) SEGMENTALLY ASSEMBLED (MODEL DDX DELUGE VALVE SOLD SEPARATELY)
  - \*3) FULLY ASSEMBLED TO MODEL DDX DELUGE VALVE WITH CONTROL VALVE
  - 4) FULLY ASSEMBLED TO MODEL DDX DELUGE VALVE WITHOUT CONTROL VALVE

ALL STEEL COMPONENTS OF THE TRIM ASSEMBLIES ARE GALVANIZED

RECOMMENDED INSTALLATION LOCATION FOR A FIRE DEPT. CONNECTION (FDC) IS ABOVE THE MODEL DDX DELUGE VALVE.

THE CONTROL (BUTTERFLY) VALVE, ADDONING COUPLINGS, REDUCING BUSHING, AND TUBING CONNECTOR ARE INCLUDED IN THE "FULLY ASSEMBLED TO MODEL DDX DELUGE VALVE WITH CONTROL VALVE" TRIM CONFIGURATION ONLY. REFER TO PAGE #20 OF THIS BULLETIN FOR PART NUMBER/ORDERING INFORMATION.

511FG06E

Fig. 6

## Maintenance

Reliable Deluge Valves and associated equipment shall periodically be given a thorough inspection and test. NFPA 25 provides minimum requirements for inspection, testing and

maintenance. The Deluge Valve should be tested, operated, cleaned, and inspected at least annually and parts replaced as required.

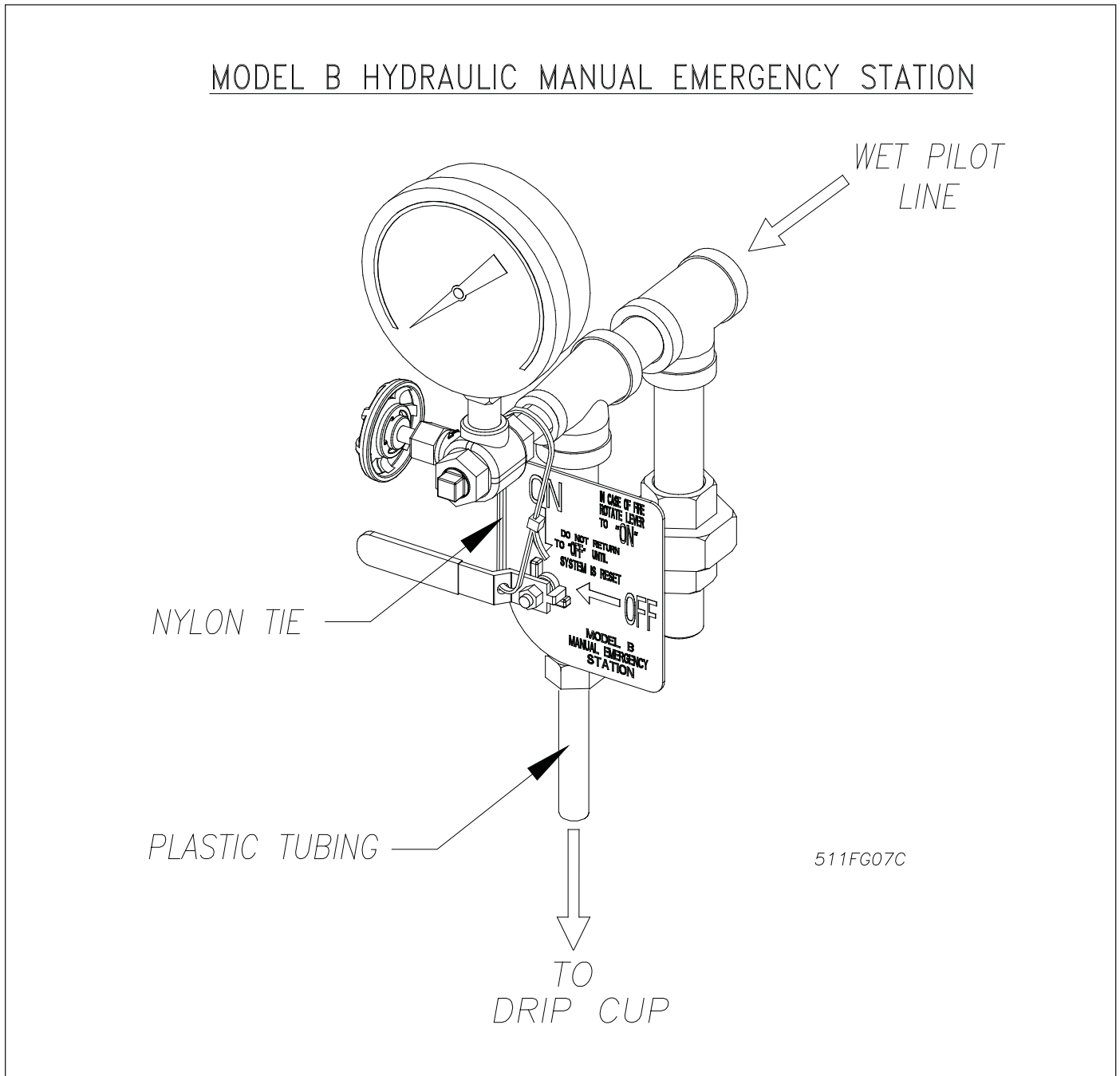
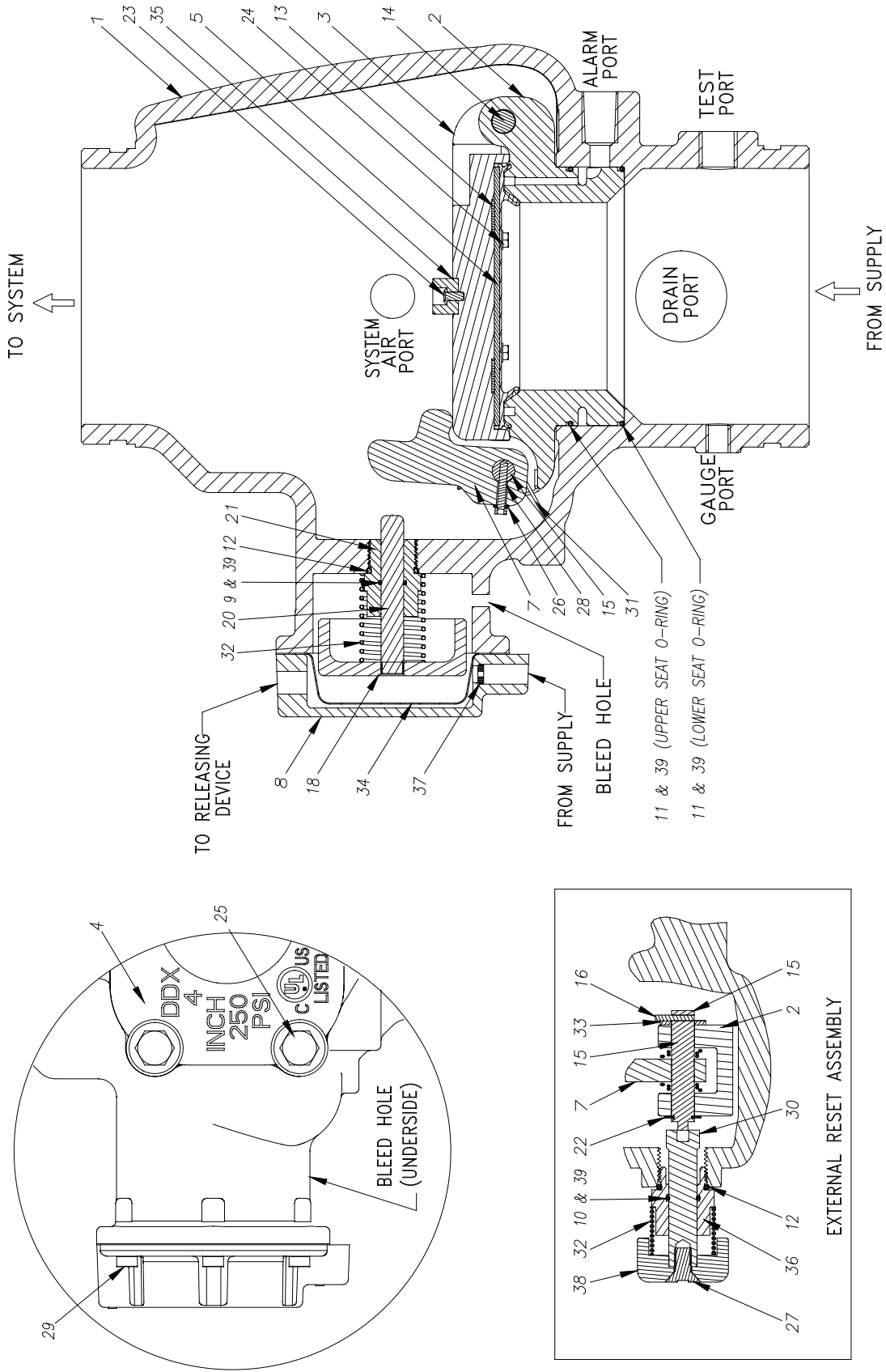

Fig. 7

MODEL DDX DELUGE VALVE [4"(100MM), 6"(150MM) & 165 MM]



511FG08F

Fig. 8

**Model DDX 4" (100mm), 6" (150mm) & 165mm Deluge Valves Parts List (Refer to Fig. 8)**

Item No.	Part Number			Description	No. Req'd
	4"(100mm) Valve	6"(150mm) Valve	165mm Valve		
1	91006005	91006007	91006027	Valve Body	1
2	96016004	96016006	96016006	Seat	1
3	91916004	91916006	91916006	Clapper	1
4	92116064	92116066	92116065	Cover	1
5	93416004	93416006	93416006	Seal Faceplate Subassembly	1
6	93706004	93706006	93706006	Gasket, Cover (Not Shown)	1
7	94506004	94506006	94506006	Lever	1
8	92126006			Cover, Pushrod	1
9	95406407			O-ring (014)	1
10	95406007			O-ring (114)	1
11	95406006	N/A		O-ring (156)	2
	N/A	95406016		O-ring (161)	
12	95406024			O-ring (912)	2
13	93706001	N/A	N/A	Gasket, Clapper, 4"	1
	N/A	93706002	93706002	Gasket, Clapper, 6"	
14	96216086			Hinge Pin, Clapper	1
15	96216046			Pin, Lever	1
16	95606131			Threaded Stud, #10-32 x 3/4"	1
17	96216066			Pin, Locking, Seat (Not Shown)	2
18	95106006			Piston	1
19	95200038			Plug, Socket, Ø3/8"-18 NPT (Not Shown)	2
20	95506006			Pushrod	1
21	93916006			Pushrod Guide	1
22	95306267			Ring, Retaining (2 Assembled to Item #14)	3
23	95606128			Screw, Button Head, #10-32 x 3/8"	1
24	95606129			Screw, Hex Washer Head, #10-32 x 3/8"	4
25	95606107	N/A	N/A	Screw, Hex Cap, Ø1/2"-13 x 1-1/2"	6
	N/A	91106006	91106006	Screw, Hex Cap, Ø5/8"-11 x 1-3/4"	
26	96906111			Spring Lock Washer, #10	1
27	95606127			Screw, C'sunk Cap Head, Ø3/8"-16 x 3/4"	1
28	95606130			Screw, Socket Head, #10-32 x 1"	1
29	95606114			Screw, Socket Head, Ø1/4"-20 x 5/8"	6
30	93916066			Shaft, Reset	1
31	96406004			Spring, Lever	1
32	96406906			Spring	2
33	96906904			Teflon Washer, Ø 1/2" (2 Assembled to Item No.14)	3
34	95276006			Diaphragm	1
35	92306006			Disc, Bumper	1
36	94106066			Housing, Reset	1
37	94206406			Inlet, Orifice	1
38	94356006			Knob, Reset	1
39	85000050			O-ring Grease, DuPont™ Krytox® GPL-201	A/R

## Resetting the Model DDX Deluge Valve System

Refer to Figs. 5, 8, & 9.

1. Close the valve controlling water supply to the Deluge Valve and close valve A (Fig. 9).
2. Open main drain valve B (Fig. 9) and drain system.
3. Open all drain valves and vents at low points throughout the system, closing them when flow of water has stopped. Open valve D (Fig. 9).
4. With valve G (Fig.9) open, push in the plunger of ball drip valve E (Fig. 9), forcing the ball from its seat to verify that there is atmospheric pressure inside the main valve chamber.
5. Push in and rotate external reset knob (#38, Fig. 8) clockwise, until you hear a distinct noise indicating that the clapper has reset.
6. Inspect and replace any portion of the detection system subjected to fire conditions.
7. Open valve A (Fig. 9) and allow water to fill the push rod chamber. Close valve D (Fig. 9).
8. Bleed all air from the actuation piping.
  - A. Wet Pilot Trim — bleed the entire wet pilot line until all air is removed at the most remote sprinkler.
  - B. Electric Actuation Trim — open the solenoid valve by operating a detector or an electric manual emergency station. While water is flowing through the solenoid valve, cause it to close. Refer to Bulletin 700, "Special Hazards & Special Systems" for details.
  - C. Dry Pilot Trim — open valve D (Fig. 9) allowing water to flow through the pilot line actuator. When all air has been expelled from the release line, and there is a solid flow of water into the drain cup J (Fig. 9), apply compressed air or nitrogen through the pressure maintenance device to close the pilot line actuator. Subsequently, close valve D (Fig. 9) or (#7, Fig. 5) and adjust the air or nitrogen pressure to the appropriate value in Table A as indicated on air pressure gauge (#26, Fig. 5).
9. Check that valves D (Fig. 9) and F (Fig. 9) are closed and that valve G is open (Fig. 9). Open slightly the valve controlling water supply to the Deluge Valve, closing the main drain valve B (Fig. 9) when water flows. Observe if water leaks through ball drip valve E (Fig. 9), into drain cup J (Fig. 9) (Be sure that valve G (Fig. 9) is open). If no leak occurs the water seat is tight. Open slowly but fully the valve controlling water supply to the Deluge Valve. Verify that it is fully opened and properly monitored.
10. Valve A (Fig. 9) must remain open when the Deluge Valve has been reset, to maintain water pressure in the push rod chamber.
11. Verify that the Model B Manual Emergency Station, valve D (Fig. 9) is sealed in the OFF position with the appropriate nylon tie.
2. **Alarm line** — be sure that valve G (Fig. 9) is opened and remains in this position.
3. **Other trimming valves** — check that valve A (Fig. 9) is open, as well as all of the pressure gauge's "3-way valves. Valves D, F, & H (Fig. 9) should be closed.
4. **Ball drip valve E (Fig. 9)** — Make sure valve G (Fig. 9) is open. Push in on the plunger to be sure ball check is off its seat. If no water appears, the Deluge Valve's water seat is tight. Inspect the bleed hole (see Fig. 8) on the underside of the push rod chamber for leakage.
5. **Dry pilot trim** — check air gauge pressure for conformance to Table A.
6. **Releasing device** — check outlet of the releasing device (i.e., the dry pilot line actuator, solenoid valve, or the hydraulic manual emergency station) for leakage. Also verify that tubing drain lines from releasing devices are not pinched or crushed which could prevent proper releasing of the Deluge Valve.
7. **Testing alarms** — Make sure valve G (Fig. 9) is open. Open valve F (Fig. 9) permitting water from the supply to flow to the electric sprinkler alarm switch and to the mechanical sprinkler alarm (water motor). After testing, close this valve securely. Push in on the plunger of ball drip valve E (Fig. 9) until all of the water has drained from the alarm line.
8. **Operation test** — Open the Model B Manual Emergency Station, valve D (Fig. 9).

**Note:** An operational test will cause the Deluge Valve to open and flow water into the sprinkler system.
9. Secure the Model B Manual Emergency Station, valve D (Fig. 9), in the OFF position with nylon tie after Deluge Valve is reset.

## Testing Detection System Without Operating Deluge Valve

Refer to Figs. 5 & 9.

1. Close the valve controlling water supply to Deluge Valve and open the main drain valve B (Fig. 9).
2. Verify that valve A (Fig. 9) is open, allowing water to enter the push rod chamber.
3. Operate detection system —
  - A. Wet Pilot Trim — open Model B Manual Emergency Station, valve D (Fig. 9).
  - B. Dry Pilot Trim — directly above the Model LP Dry Pilot Line Actuation, remove the ¼" pipe plug ( #49 Fig. 5) and open the ¼" three-way valve (#60, Fig. 5).
  - C. Electric Actuation — refer to Bulletin 700.
4. Operation of the detection system must result in a sudden drop of water pressure in the push rod chamber.
5. Reset detection system — reverse operations performed in step three above and then proceed according to the directions listed in the "Resetting Model DDX Deluge Valve Systems" section of this bulletin for resetting the Deluge Valve.

## Inspection and Testing

Refer to Figs. 8 & 9.

1. **Water supply** — be sure the valves controlling water supply to the Deluge Valve are opened fully and properly monitored.

## Draining Excess/Condensate Water From System

Refer to Fig. 9

1. Close the valve controlling water supply to Deluge Valve. Also close valve A and open main drain valve B.
2. Open condensate drain valve H until all water has drained. Close valve H.
3. Close main drain valve B. If system contains pressurized air, allow air pressure to come back up to specification. Open valve A and the valve controlling the water supply to the Deluge Valve.

## Maintenance Procedures - Model DDX Deluge Valve

Refer to Figs. 5, 8, & 9.

1. **Mechanical sprinkler alarm (water motor-not shown) not operating:** This is most likely caused by a clogged screen in the strainer of the water motor. Proceed as follows: Remove plug from the strainer. Remove and clean the screen. Replace the screen and the plug, and then tighten securely (Ref. Bulletin 613).
2. **Leakage out of the ball drip valve E (Fig. 9).**

- a. **Water leakage due to water column in deluge systems:**

This condition can be caused by leakage past the system side of the Model DDX Deluge Valve's seal faceplate subassembly (#5, Fig. 8). Be sure that this surface is free of any type of debris. To eliminate leakage due to water column in a deluge system, refer to the section in this bulletin marked "Draining Excess/Condensate Water From System". If the problem continues proceed to the following section.

- b. **Leakage, air or water from the ball drip valve, E (Fig. 9):**

If system air is leaking out the ball drip valve, the problem is either damage to the airside of the Model DDX Deluge Valve's seal faceplate subassembly (#5, Fig. 8), seat (#2, Fig. 8), or the upper seat O-ring (#11, Fig. 8).

If supply water is leaking out the ball drip valve, the problem could be caused by damage to the Model DDX Deluge Valve's seal faceplate subassembly (#5, Fig. 8), seat (#2, Fig. 8), or lower seat O-ring (#11, Fig. 8). The following section provides instructions to correct both conditions:

- A) Shut down the valve controlling the water supply to the Deluge Valve and open the 2" main drain valve B (Fig. 9). Open the water column drain valve H (Fig. 9). Close the push rod chamber supply valve A (Fig. 9) and open the Model B Manual Emergency Station D (Fig. 9).
- B) Remove the Deluge Valve's front (handhold) cover (#4, Fig. 8) and inspect the seat (#2, Fig. 8), clapper (#3, Fig. 8), and seal faceplate subassembly (#5, Fig. 8) for damage.

If inspection indicates damage to the clapper (#3, Fig. 8) or seal faceplate subassembly (#5, Fig. 8) only, then the clapper subassembly can be removed as follows:

At the rear of the valve, disconnect the water column drain trim section starting with the elbow connector (#17, Fig. 5). Then remove the 1/4" globe valve (#28, Fig. 5) followed by the 3/4" x 1/4" reducing bushing (#12, Fig. 5). Remove the retaining ring (handhold cover side) from the clapper hinge pin (#14, Fig. 8) and push this pin through the water column drain line and remove the clapper subassembly. Remove the four retaining screws (#24, Fig. 8) holding the seal faceplate subassembly (#5, Fig. 8). Inspect the clapper (#3, Fig. 8) visually before re-installing. Apply a small amount of silicone-based lubricant to the four retaining screws. Install a new seal faceplate subassembly. Torque the retaining screws to approximately 40 inch-pounds and reassemble. If the seat (#2, Fig. 8) is damaged or it is suspected that the leakage is through the lower O-ring (#11, Fig. 8), the seat-clapper subassembly is easily removed as a unit as follows:

Using a 5/16" Allen wrench, remove the two 3/8" NPT pipe plugs (#19, (not shown) Fig. 8) located on the side of the Model DDX Deluge Valve. The seat-clapper subassembly is retained by two locking pins (#17, (not shown) Fig. 8). The centers of these pins have a 1/4"-20 threaded hole. Remove the two locking pins by engaging them with a 1/4"-20 screw and pulling them out (The two locking pins are not threaded, so turning them with the attached 1/4"-20 screw or threaded rod is not recommended. A proven method is to use 1/4"-20 threaded rod with a locknut on the unassembled end. Grab hold of the locknut with pliers or vice-grips and tap the pliers or vice-grips in the direction away from the Deluge Valve. Doing so should pull the locking pins out of the Deluge Valve.). With the clapper (#3, Fig. 8) in the closed position (not latched), dislodge the seat-clapper subassembly from the valve body by inserting two slotted screwdrivers under the lever and clapper mounting ears and pry up until the seat-clapper subassembly is free of its bore. Reach into the valve and grasp the seat-clapper subassembly from the sides. Lift up and rotate the seat-clapper subassembly through 90 degrees about the centerline axis of the Model DDX Deluge Valve so that the lever side of the seat-clapper subassembly faces the outlet of the Deluge Valve. Rotate the seat-clapper subassembly around the centerline of the Deluge Valve until the top of the clapper faces the handhold opening and then pull it out clapper hinge-pin side first. Visually examine all components of the seat-clapper subassembly replacing any component that appears damaged. New O-rings (#11, Fig. 8) should always be used for reassembly.

## Reassembly:

It is likely that the lower seat O-ring (#11, Fig. 8) has remained at the bottom of the Deluge Valve body's bore. Discard this O-ring and clean the bore. Lubricate the bore with O-ring grease and place the lower O-ring on the step at the bottom of the bore, verifying that it is in full contact with the bore. Lubricate the bottom step and upper seat O-ring (#11, Fig. 8) of the refurbished seat-clapper subassembly. Insert the seat-clapper subassembly into the handhold opening of the Deluge Valve lever-first, rotating it until the lever side faces the outlet of the Deluge Valve. Rotate the seat-clapper subassembly until the lever (#7, Fig. 8) faces the push rod (#20, Fig. 8), then drop the seat-clapper subassembly into the Deluge Valve's bore. Verify that the seat-clapper subassembly is in the fully down position and check to see that the lever lines up with the push rod. Adjust if necessary. Clean and lubricate the two locking pins (#17, (not shown) Fig. 8) with O-ring lubricant and drive them into the Deluge Valve body. Then reinstall the 3/8" NPT pipe plugs (#19, (not shown) Fig. 8). Reassemble the handhold cover (#4, Fig. 8) and set up the Model DDX Deluge Valve as per the section "Resetting Model DDX Deluge Valve Systems."

### 3. Leakage out of the push rod chamber vent hole:

A small bleed hole is located on the underside of the push rod chamber (see Fig. 8). If there is air or water leakage coming out of this hole, do the following:

- a) Shut down the valve controlling water supply to the Deluge Valve. Relieve the inlet pressure by opening the 2" drain valve B (Fig. 9). Close the valve A (Fig. 9) that supplies water to the push rod chamber, and open the Model B Manual Emergency Station, valve D (Fig. 9).
- b) Remove the trim at the unions nearest to the push rod chamber cover (#8, Fig. 8).
- c) Take the push rod chamber cover (#8, Fig. 8) off by removing the six retaining screws (#29, Fig. 8).

## CONDITION ONE (Water coming out of the bleed hole):

Water coming out of the bleed hole is caused by a leaking diaphragm (#34, Fig. 8). Visually inspect the push rod chamber cover (#8, Fig. 8) and piston (#18, Fig. 8) to determine what could have damaged the diaphragm and correct. Install a new diaphragm. **NOTE:** The diaphragm has two different surfaces, it is not bi-directional. It will fail if installed backwards! Roll the diaphragm so that the smooth surface (the pressure side) conforms to the inside of the push rod chamber cover and reassemble the six retaining screws (#29, Fig. 8) with an installation torque of 15 foot-pounds. Set up the Model DDX Deluge Valve as per the section "Resetting Model DDX Deluge Valve Systems."

## CONDITION TWO (System Air coming out of the bleed hole):

System air coming out of the bleed hole is caused by a defective O-ring assembled to the push rod guide (#21, Fig. 8). Remove the piston-push rod subassembly, push rod spring (#32, Fig. 8), and push rod guide (#21, Fig. 8). Verify by hand turning, that the push rod cannot be unscrewed from the piston. Replace all O-rings and the push rod guide. The correct installation torque for the push rod guide is 35 inch-pounds. **CAUTION:** Do not over tighten the push rod guide. Reassemble the components that were initially removed. Re-install the diaphragm (#34, Fig. 8) if it appears to be in good shape, otherwise, replace it also. **NOTE:** The diaphragm has two different surfaces, it is not bi-directional. It will fail if installed backwards! Roll the diaphragm so that the smooth surface (the pressure side) conforms to the inside of the push rod chamber cover and reassemble the six retaining screws (#29, Fig. 8) with an installation torque of 15 foot-pounds. Set up the Model DDX Deluge Valve as per the section "Resetting Model DDX Deluge Valve Systems."

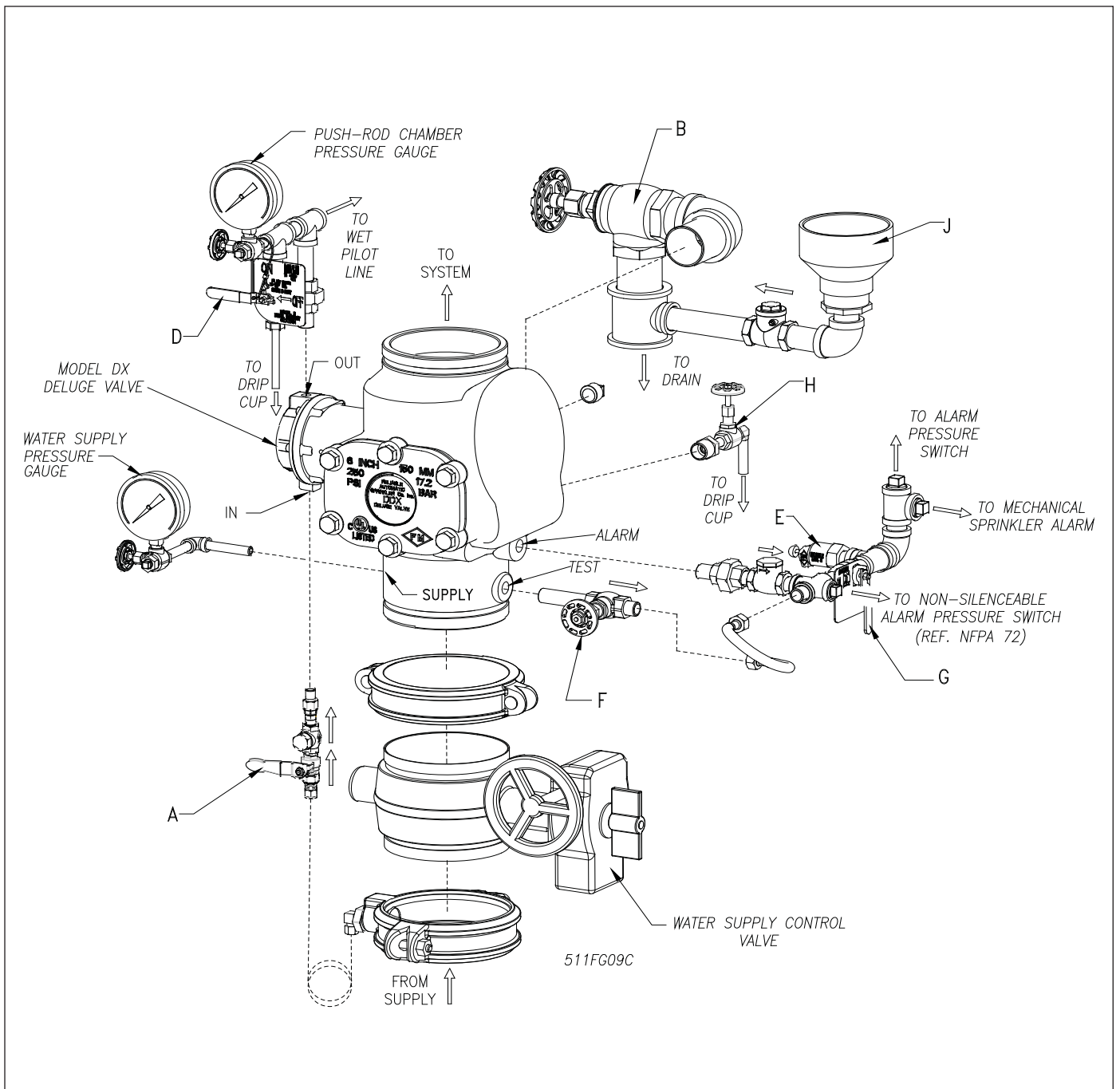

Fig. 9

## Ordering Information

### Specify:

- **Valve Model & Size** — 4" (100 mm) Model DDX Deluge Valve (P/N 6103040026), 6" (150 mm) Model DDX Deluge Valve (P/N 6103060024), 165mm Model DDX Deluge Valve (P/N 6103060028)
- **Trim** — Wet Pilot Trim, Dry Pilot Trim, or Electric Actuation Trim. Each trim set is available in individual parts, in time-saving, segmentally assembled kit forms, or fully assembled to the Model DDX Deluge Valve with or without a control valve). The Electric Actuation trim is available with a 175 psi (12,1 bar) or 250 psi (17,2 bar) rated solenoid valve.
- **Low Air Pressure Switch (Dry Pilot Line Only)** — UL/FM Approved (System Sensor Model EPS40-2) or ULC Listed (System Sensor Model EPSA40-2).

### Wet Pilot Line Deluge

Trim Configurations	Trim Part Numbers		
	For 4" (100mm) Valve	For 6" (150mm) Valve	For 165mm Valve
Fully Assembled to DDX Valve w/Control Valve	6505040200	6505060200	Not Available
Fully Assembled to DDX Valve w/o Control Valve	6505040201	6505060201	6505065201
Segmentally Assembled (DDX Valve Sold Separately)	6503001003		

### Dry Pilot Line Deluge

Trim Configurations	Trim Part Numbers		
	For 4" (100 mm) Valve	For 6" (150 mm) Valve	For 165 mm Valve
Fully Assembled to DDX Valve w/ Control Valve	6505040205	6505060205	Not Available
Fully Assembled to DDX Valve w/o Control Valve	6505040206	6505060206	6505065206
Segmentally Assembled (DDX Valve Sold Separately)	6503001108		
Individual Parts (DDX Valve Sold Separately)	6503001107		
Fully Assembled to DDX Valve w/Control Valve	6505040208	6505060208	Not Available
Fully Assembled to DDX Valve w/o Control Valve	6505040209	6505060209	6505065207
Segmentally Assembled (DDX Valve Sold Separately)	6503001110		
Individual Parts (DDX Valve Sold Separately)	6503001109		

UL/FM Approved Pressure Switch

ULC Listed Pressure Switch

### Electric Actuation Deluge (Explosion - Proof Solenoid Valve available upon request)

Trim Configurations	Trim Part Numbers		
	For 4" (100 mm) Valve	For 6" (150 mm) Valve	For 165 mm Valve
Fully Assembled to DDX Valve w/ Control Valve	6505040210	6505060210	Not Available
Fully Assembled to DDX Valve w/o Control Valve	6505040211	6505060211	6505065211
Segmentally Assembled (DDX Valve Sold Separately)	6503001507	6503001003	
Individual Parts (DDX Valve Sold Separately)	6503001505	6503001002	
Fully Assembled to DDX Valve w/ Control Valve	6505040215	6505060215	Not Available
Fully Assembled to DDX Valve w/o Control Valve	6505040216	6505060216	6505065216
Segmentally Assembled (DDX Valve Sold Separately)	6503001508		
Individual Parts (DDX Valve Sold Separately)	6503001506		

175 psi (12,1 bar) Rated Solenoid Valve

250 psi (17,2 bar) Rated Solenoid Valve

**Note:** For metric installations, a 2" NPT x R2. ISO 7/1 x Close Nipple (Reliable P/N 98543401) is sold separately as an adapter for the single drain outlet of the trims.

- **Additional equipment** — Air compressors, electric detection, actuation equipment, and mechanical sprinkler alarms must be ordered separately. These devices are described in Bulletin 700.

# Installation Dimensions

Installation Dimensions in Inches (mm)																
VALVE	A	B	C	*D	E	F	G	H	J	K	L	M	N	P	Q	R
<b>4" (100mm)</b>	5¼ (133)	6¾ (171)	9½ (241)	14 (355)	29 (603)	22¾ (578)	30¾ (781)	8½ (216)	13¾ (349)	5½ (140)	8½ (216)	13½ (343)	2½ (64)	6¼ (159)	12 (305)	11¼ (286)
<b>6" (150mm) &amp; 165mm</b>	6¼ (159)	7¾ (197)	10½ (267)	16 (406)	30 (767)	23¾ (603)	31¾ (806)	8½ (216)	13¾ (349)	5½ (140)	8½ (216)	13½ (343)	3¼ (83)	8¾ (222)	12½ (318)	12¼ (311)

\* Total take out dimension for Fully Assembled to DDX Valve w/Control Valve Configurations:

4" - 20<sup>7</sup>/<sub>16</sub>, 6" - 23<sup>3</sup>/<sub>4</sub>, 165 mm - N/A

DRY PILOT LINE TRIM SHOWN (FULLY ASSEMBLED WITHOUT CONTROL VALVE)

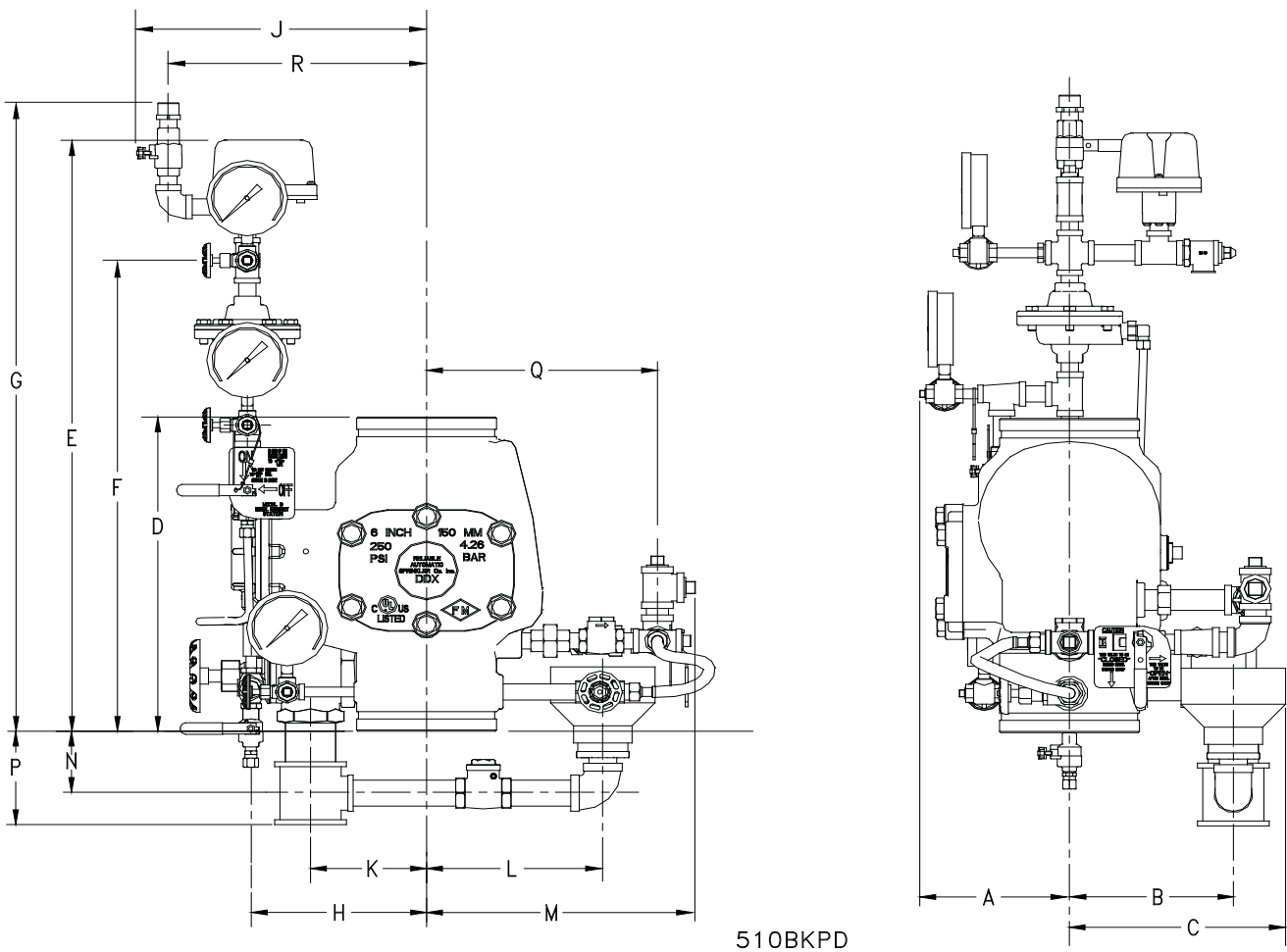

## **SOLENOID VALVE INSPECTIONS, TESTS AND MAINTENANCE**

**WARNING: THE OWNER IS RESPONSIBLE FOR MAINTAINING THE FIRE PROTECTION SYSTEM IN PROPER OPERATING CONDITION. ANY SYSTEM MAINTENANCE OR TESTING THAT INVOLVES PLACING A CONTROL VALVE OR DETECTION SYSTEM OUT OF SERVICE MAY ELIMINATE THE FIRE PROTECTION OF THAT SYSTEM. PRIOR TO PROCEEDING, NOTIFY ALL AUTHORITIES HAVING JURISDICTION. CONSIDERATION SHOULD BE GIVEN TO EMPLOYMENT OF A FIRE PATROL IN THE AFFECTED AREA.**

**WARNING: PRIOR TO OPERATING THE SOLENOID VALVE, BE SURE TO CLOSE THE SYSTEM CONTROL VALVE TO AVOID UNINTENTIONAL OPERATION OF THE DELUGE VALVE**

1. Inspections: It is imperative that the system be inspected and tested in accordance with NFPA 25 on a regular basis. The frequency of the inspections may vary due to contaminated water supplies, corrosive water supplies, or corrosive atmospheres. In addition, the alarm devices, detection systems, or other connected trim may require a more frequent schedule. Refer to the system description and applicable codes for minimum requirements.
2. The valve must be inspected at least monthly for cracks, corrosion, leakage, etc., and cleaned, repaired, or replaced, or replaced as necessary.
3. If leakage is suspected through the solenoid valve, the valve diaphragms and seats should be inspected and if necessary, repaired or replaced.

**WARNING: CLOSE SYSTEM CONTROL VALVE, TURN OFF POWER SUPPLY, AND DEPRESSURIZE VALVE BEFORE DISASSEMBLING VALVE. IT IS NOT NECESSARY TO REMOVE THE VALVE FROM THE PIPE LINE TO MAKE INSPECTIONS.**

4. When lubricating valve components, use high grade silicone grease (Dow Corning® 111 Compound Lubricant or equal).
5. When reassembling, tighten parts to torque values indicated in the manufacturer's maintenance instructions (packed with valve).
6. After maintenance is completed, operate the valve a few times to be sure of proper operation. A metallic "click" signifies the solenoid is operating.
7. All service must be performed by qualified personnel. Upon completion of inspections or replacement of the valve, the entire system must be checked for proper operation. See appropriate system description and testing instructions for additional information.

---

The equipment presented in this bulletin is to be installed in accordance with the latest published Standards of the National Fire Protection Association, Factory Mutual Research Corporation, or other similar organizations and also with the provisions of governmental codes or ordinances whenever applicable. Products manufactured and distributed by Reliable have been protecting life and property for over 90 years, and are installed and serviced by the most highly qualified and reputable sprinkler contractors located throughout the United States, Canada and foreign countries.

Manufactured by

**Reliable**<sup>®</sup>

The Reliable Automatic Sprinkler Co., Inc.  
(800) 431-1588 Sales Offices  
(800) 848-6051 Sales Fax  
(914) 829-2042 Corporate Offices  
www.reliablesprinkler.com Internet Address



Revision lines indicate updated or new data.  
EG. Printed in U.S.A 08/11 P/N 9999970270