

Reliable®

Model A Deluge Valve 2½" (65mm)

Features

1. Differential diaphragm type – simple – lightweight – dependable.
2. Easily trimmed for actuation by:
 - Manual devices
 - Wet pilot sprinklers
 - Dry pilot actuators
 - Solenoid valves
3. Limited compression seat seal.
4. External hydraulic reset.
5. Three connection styles available:
 - ANSI pipe threads
 - Grooved ends
 - Metric pipe threads
6. Separately replaceable diaphragm and seat seal.

Listings & Approvals

1. Listed by Underwriters Laboratories, Inc. (UL)
2. Listed by Underwriters Laboratories of Canada (ULC)
3. Scientific Services Laboratory of Australia (SSL).
4. Approved by Factory Mutual (FM)
5. Loss Prevention Council (LPC, UK).
6. N.Y.C. BS & A No. 587-75-SA.

The Reliable Model A, 2½" (65mm) Deluge Valve is a hydraulically operated differential diaphragm type deluge valve used to control the water supply to deluge or preaction systems. Deluge systems use open sprinklers or nozzles as discharge outlets in the fire area while preaction systems use closed sprinklers or nozzles.

Both systems use separate detection devices to control the operation of the deluge valve. Two simple trim arrangements allow for actuation of the Reliable Model A Deluge Valve by manual, hydraulic, pneumatic or electric devices such as break glass stations, wet pilot or dry pilot sprinklers and thermal or smoke detectors.

A detailed description of various deluge and preaction systems is provided in Bulletins 503K, 707D, 713B and 715B.

General

The Model A, 2½" (65mm) Deluge Valve is a direct diaphragm actuated valve. There are no moving linkages or mechanisms to wear or jam or internally reset. The direct diaphragm operation allows the valve to be reset by external hydraulic means. The valve has been

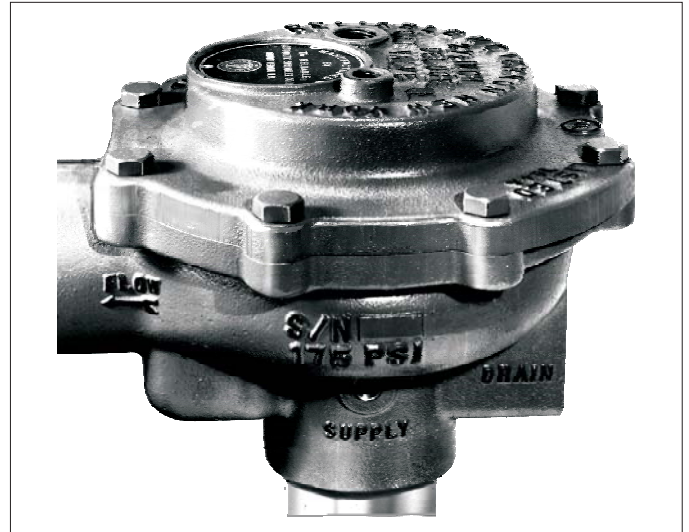

ruggedly designed to provide many years of trouble free operation.

The design features a limited compression piston (clapper) rubber seal installed in the valve body. This feature prevents localized compression set of the rubber seal. Compression set of the clapper seal in other valves requires exact clapper-to-seat realignment when resetting and may cause reseating leakage. The limited compression is accomplished by a metal piston stop in the rubber seal-to-valve body retainer ring. The seal retainer ring metal stop allows the piston to squeeze the seal only a predetermined fixed amount regardless of inlet supply pressure. The piston cannot continue to compress the seal as the supply pressure increases, causing higher piston closing forces.

The valve design also features a separately replaceable molded diaphragm which incorporates an "O" Ring end configuration on the inside and outside sealing diameters. The "O" Ring formed ends provide more positive retention, clamping and sealing of the diaphragm to piston and diaphragm to valve body.

The valve is externally hydraulically reset, eliminating the lengthy process of removing cover plates. After the actuation device is reclosed, or, in the case of wet pilot sprinklers, replaced, pressure is resupplied to the upper portion of the diaphragm and piston. This causes the piston to close, resetting the deluge valve.

The design of Reliable's 2½" (65mm) Deluge Valve provides for longer term trouble free positive operation without the need of internal linkage and clapper alignment for resetting.

Operation

Reliable's Model A, 2½" (65mm) Deluge Valve is a quick opening hydraulically operated, diaphragm actuated type valve. The Model A consists of three chambers, top (pressurized), outlet (normally dry) and inlet (pressurized). The three chambers are isolated from each other by the diaphragm and piston and the compression limited seat seal. In the closed position (Figure 1) supply pressure in the top chamber acts across the diaphragm and piston, holding the piston on the seat against inlet supply pressure. The diaphragm pressure area is greater than the seat pressure area, providing a force imbalance of about 3 to 1.

When a fire is detected, the top chamber is vented to atmosphere through the outlet port via opened actuation devices. The top chamber pressure cannot be replenished through the restricted inlet port as rapidly as it is vented from the outlet port, and the chamber pressure falls instantaneously. When the top chamber pressure reaches about one third the supply pressure, the upward force of the supply pressure acting on the piston face becomes greater than the downward force of the diaphragm and the piston moves up to the open position (Figure 1).

Once the piston has opened, water flows from the supply through the deluge valve into the piping system and alarm outlet to the alarm devices. The valve maintains the open position until the open releasing device is closed. **CAUTION – THE RELEASING DEVICE MUST BE MAINTAINED OPEN TO PREVENT CLOSING OF THE MODEL A DELUGE VALVE.**

Detection and Actuation

In general, the Reliable Model A, 2½" (65mm) Deluge Valve can be actuated by any listed or approved device which opens sufficiently to vent the top chamber in response to a fire. The actuation device is simply connected to the top chamber outlet port. When the actuation device operates and vents the top chamber, the deluge valve opens.

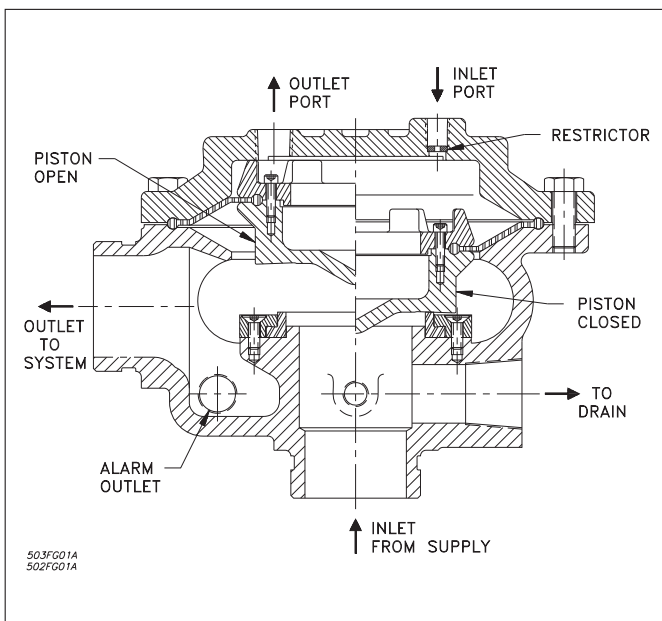

Figure 1—Model A Deluge Valve Open and Closed Positions

Typical releasing devices include hydraulic manual emergency stations, pilot line detectors, dry pilot actuators and solenoid valves. Wet pilot line detectors perform both deluge valve releasing and fire detection functions. Dry pilot line detectors are detectors that initiate dry pilot releasing devices.

The use of a solenoid valve for deluge valve releasing enables various types of electrical fire detection devices to be used. Typical detection devices include electrical emergency pull stations, thermal detectors and ionization or photoelectric smoke detectors. Electrical detection and releasing equipment used in Supertrol Electrical Systems is described in Bulletins 707 and 708.

Valve Description

1. Rated working pressure 175 psi (12,1 bar).
2. Factory hydrostatic test pressure 350 psi (24,1 bar).
3. End and trim connections – three valve connection styles are available:
 - a. 2½" American Standard taper pipe threads inlet and outlet per ANSI B 2.1:
 - Threaded openings per ANSI B 2.1.
 - Reliable's standard trim sets are compatible with American Standard taper pipe threads.
 - Color — Black.
 - b. 2½" (65mm) grooved inlet and outlet:
 - Reliable's standard trim sets are compatible with grooved valves.
 - Groove dimensions per ANSI/AWWA C606.
 - Color — Black.
 - Threaded openings per ANSI B2.1.

Groove Dimensions in Inches			
Outlet Diameter	Groove Diameter	Groove Width	Outlet Face to Groove
2 7/8	2.720	5/16	5/8

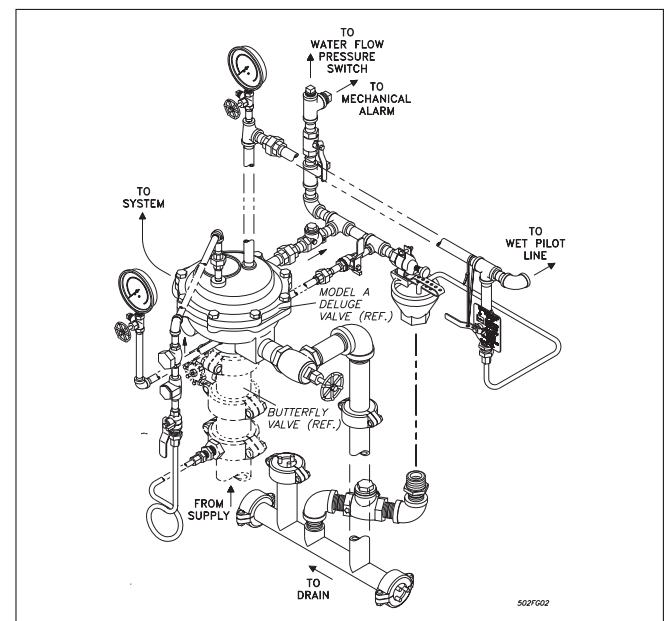

Figure 2—Model A Deluge Valve with Wet Pilot Trim and Optional Drain Manifold Trim

- c. 2½" (65mm) Metric pipe threads inlet and outlet per ISO 7/1
 - Threaded openings per ISO 7/1-Rp
 - Reliable's standard trim sets may be used with metric valves, providing trim is assembled carefully and extra thread sealant is applied to connections between valves and trim
 - Color — Red

4. Shipping weight — 49 lbs. (22 kg)
5. Friction loss — Expressed in equivalent length of Sch. 40 pipe, based on Hazen-Williams formula with C = 120. Equivalent Length = 17.1 ft.
6. Installation position: Vertical

Trim Description

The trim sets for the Reliable Model A Deluge Valves are arranged for rapid, easy and compact attachment and serve as connection points to Reliable alarm and other devices.

The Models A Deluge Valve trim sets are:

- a. Wet Pilot Trim
- b. Dry Pilot Trim
- c. Electric Actuation Trim

The Wet Pilot Trim (Fig. 2) is used when pilot line detectors or hydraulic manual emergency pull boxes are used for detection and releasing. This trim set provides 1¼" (32mm) main drain, alarm test, supply pressure gauge and top chamber supply connections. Also included in the trim are a top chamber pressure gauge, Model B Hydraulic Manual Emergency Station and a connection for releasing devices.

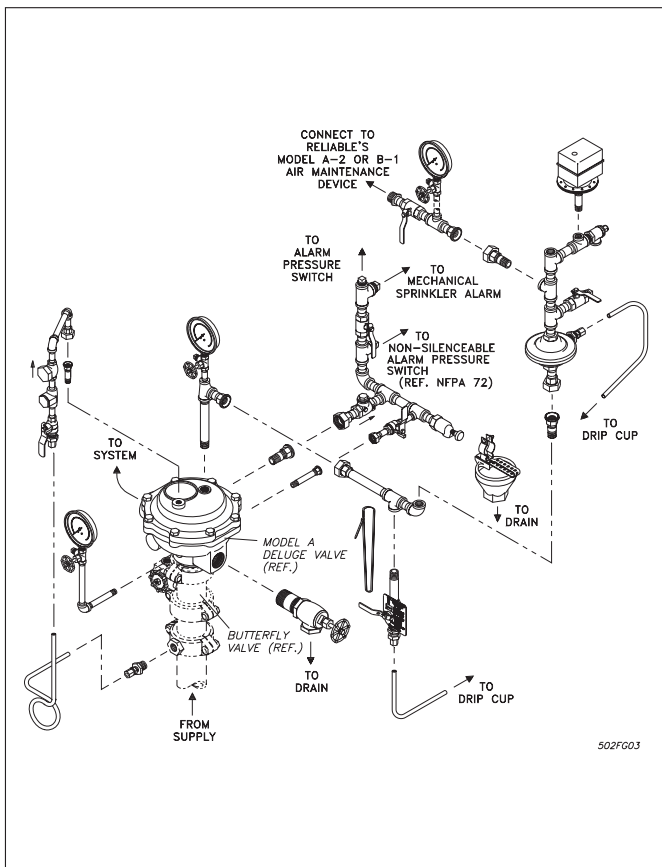

Figure 3—Model A Deluge Valve with Dry Pilot Line Trim, Preassembled

Table 1 specifies the maximum wet pilot line height for use with the Reliable Model A Deluge Valve. Refer to the appendix of Bulletin 707D for combination height and distance limitations. Use the data corresponding with the 2½" (65mm) deluge valve.

Table 1

Average Service Pressure at Valve psi (bar)	Maximum Height of Wet Pilot Line Above Valve ft. (Meter)
20 (1.38)	7.7 (2.3)
40 (2.76)	12.3 (3.8)
60 (4.14)	21.6 (6.6)
80 (5.52)	30.8 (9.4)
100 (6.89)	43.1 (13.1)
120 (8.27)	53.9 (16.4)
140 (9.65)	67.8 (20.7)
160 (11.03)	80.1 (24.4)
175 (12.06)	92.4 (28.2)

Note: 1 bar=100 kPa

The Dry Pilot Trim (Fig. 3) is used when pilot line detectors are used as the fire detection means. The Dry Pilot Trim set includes the dry pilot actuator, air and water pressure gauges, low air pressure warning switch, air pressure relief valve and connections for the air supply and pilot sprinkler lines. This trim set provides 1¼" (32mm) main drain, alarm test and top chamber connections. Also included are a top chamber pressure gauge and the Model B Hydraulic Manual Emergency Station. The dry pilot actuator is fully described in Bulletin 504.

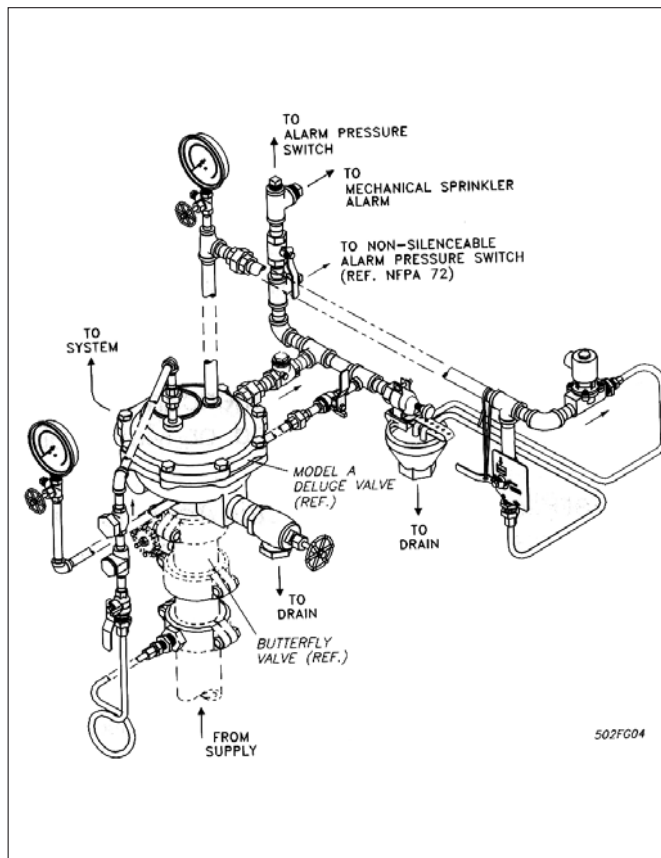

Figure 4—Model A Deluge Valve with Electric Actuation Trim

The Electric Actuation Trim (Fig. 4) is used when electric releasing are desired. This trim set includes a solenoid valve, 1¼" (32mm) main drain, alarm test, supply pressure gauge and top chamber supply connections. The top chamber pressure gauge and the Model B Hydraulic Manual Emergency Station are also included. Detailed description of electrical operation can be found in Bulletins 707D and 708A.

The Model B Hydraulic Manual Emergency Station is a standard item in all trim sets. However, the Model A Manual Emergency Station, described in Bulletin 506, is available as an option.

All valves are listed and approved by Underwriters Laboratories, Inc. Underwriters' Laboratories of Canada and Factory Mutual Research Corp. only when used with the valve manufacturer's trim sets.

Table 2 provides the recommended air pressure when the dry pilot trim set is used as the actuation means.

Table 2

Water Pressure psi (bar)	Air Pressure to be Pumped into Dry Pilot Line psi (bar)	
	Maximum	Not Less Than
20 (1.38)	10 (0.69)	20 (1.38)
50 (3.44)	15 (1.03)	25 (1.72)
75 (5.17)	20 (1.38)	30 (2.06)
100 (6.89)	25 (1.72)	35 (2.41)
125 (8.62)	30 (2.06)	40 (2.76)
150 (10.34)	35 (2.41)	45 (3.10)
175 (12.06)	40 (2.76)	50 (3.44)

Installation Dimensions

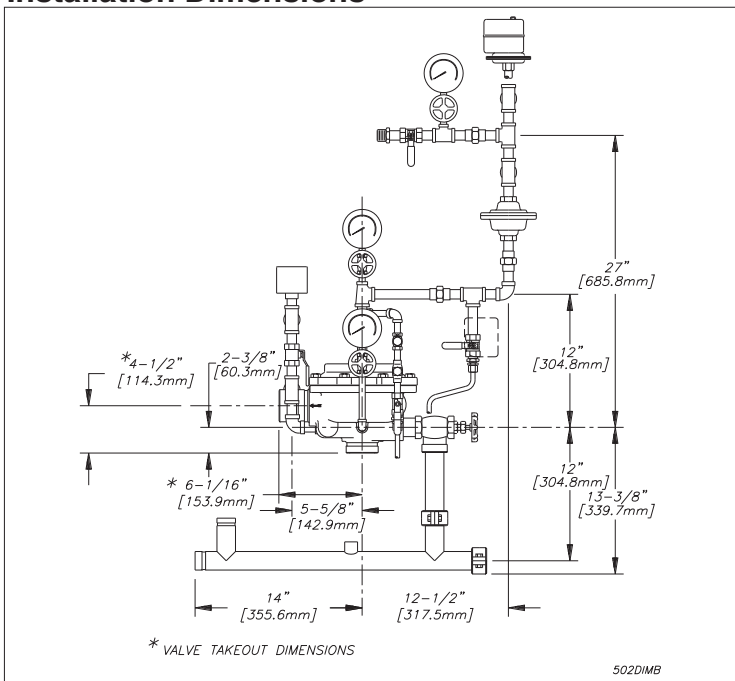

Ordering Information

Specify

- Valve Size — 2½" or 65mm. When size is specified in mm, a metric valve per Valve Description Section 3.c will be supplied.
- Inlet and outlet connection — American Standard taper pipe threads, grooved end or Metric pipe threads.
- Trim — Wet Pilot, Dry Pilot or Electric Actuation Trim. Each trim set is also available in pre-assembled kit form.
- Optional Drain Manifold — Recommended with all trim sets. Order separately. For use only with grooved deluge valves.
- Additional equipment — Air compressors, electric detection and actuation equipment and mechanical sprinkler alarms must be ordered separately. These devices are described in Bulletin 707D.

The equipment presented in this bulletin is to be installed in accordance with the latest pertinent Standards of the National Fire Protection Association, Factory Mutual Research Corporation, or other similar organization and also with the provisions of governmental codes or ordinance, whenever applicable.

Product manufactured and distributed by Reliable have been protecting life and property for 80 years, and are installed and service by the most highly qualified and reputable sprinkler contractors located throughout the United States, Canada and foreign countries

Manufactured by



The Reliable Automatic Sprinkler Co., Inc.

(800) 431-1588
 (800) 848-6051
 (914) 829-2042
<http://www.reliablesprinkler.com>

Sales Offices
 Sales Fax
 Corporate Offices
 Internet Address



Revision lines indicate updated or new data.
 EG. Printed in U.S.A. 10/06 P/N9999970054