



Reliable Riser – Residential

Reliable Riser - Residential

1" (25mm), 1½" (40mm), and 2" (50mm) sizes.
For use in NFPA 13D and 13R
Residential Systems

Features:

1. Stainless Steel body construction.
2. All brass trim.
3. Factory assembled.
4. Factory pressure tested at 200 psi. (13.8 bar).
5. Choice of trim:
 - Basic Trim (Fig.1).
 - Basic Trim with Pressure Relief Kit (Fig. 2).
 - Basic Trim with Test and Drain Valve (Fig. 3).
 - Basic Trim with Test and Drain Valve and Pressure Relief Kit (Fig. 4).
6. Choice of mounting options:
 - Supply / System lines support.
 - Support Bracket (to stud) (Figs. 5 & 6).
 - Recessed or Flush mount (to wood panel) (Fig. 7).
7. NPT (female x female) or tapered metric (female x female) connections.
8. Slim design allows for easy installation within 2" x 4" on 16" centers wood frame construction.
9. Dedicated UL Listed and ULC Listed Water Flow Detector assures optimum sensitivity. Water Flow Detector is factory installed with a metallic, weatherproof cover. Triggering flow rate is 4(15) GPM(LPM) to 10(38)GPM(LPM).

Approvals & Listings

1. Listed by Underwriters Laboratories Inc. and ULC Listed.
2. NYC MEA 258-93-E



Fig. 1 **Base Trim**



Fig. 2 **Base Trim with Pressure Relief Kit**



Fig. 3 **Base Trim with Test and Drain Valve**



Fig. 4 **Base Trim with Test and Drain Valve & Pressure Relief Kit**

Optional Trims - Technical Data:

Description	Basic Trim			Basic Trim with Pressure Relief Kit			Basic Trim with Test and Drain Valve			Basic Trim with Test and Drain Valve & Pressure Relief Kit			Take Out Dimension
	Dimensions		Weight*	Dimensions		Weight*	Dimensions		Weight*	Dimensions		Weight*	
	A inch (mm)	B inch (mm)	Lbs (kgs)	A inch (mm)	B inch (mm)	Lbs (kgs)	A inch (mm)	B inch (mm)	Lbs (kgs)	A inch (mm)	B inch (mm)	Lbs (kgs)	
1" (25mm)	11 (279)	8 $\frac{3}{4}$ (222)	7.3 (3.32)	13 $\frac{1}{2}$ (343)	11 (279)	8.7 (3.95)	11 (279)	14 $\frac{1}{4}$ (362)	9.0 (4.09)	15 (381)	14 $\frac{1}{4}$ (362)	10.6 (4.82)	8 $\frac{3}{4}$ (210)
1 $\frac{1}{2}$ " (40mm)	11 (279)	9 $\frac{1}{4}$ (235)	8.3 (3.77)	13 $\frac{1}{2}$ (343)	11 $\frac{1}{2}$ (292)	10.5 (4.77)	11 (279)	14 $\frac{3}{4}$ (375)	9.7 (4.41)	15 (381)	14 $\frac{3}{4}$ (375)	11.2 (5.09)	8 $\frac{3}{4}$ (210)
2" (50mm)	11 (279)	9 $\frac{3}{4}$ (248)	8.8 (4.00)	13 $\frac{1}{2}$ (343)	12 (305)	11.1 (5.05)	11 (279)	15 $\frac{1}{4}$ (387)	10.5 (4.77)	15 (381)	15 $\frac{1}{4}$ (387)	12.2 (5.55)	8 $\frac{3}{4}$ (210)

* Support Bracket Kit (optional) - 1 lb (0.45 kg)

All Reliable Risers have a 1" NPT drain port.

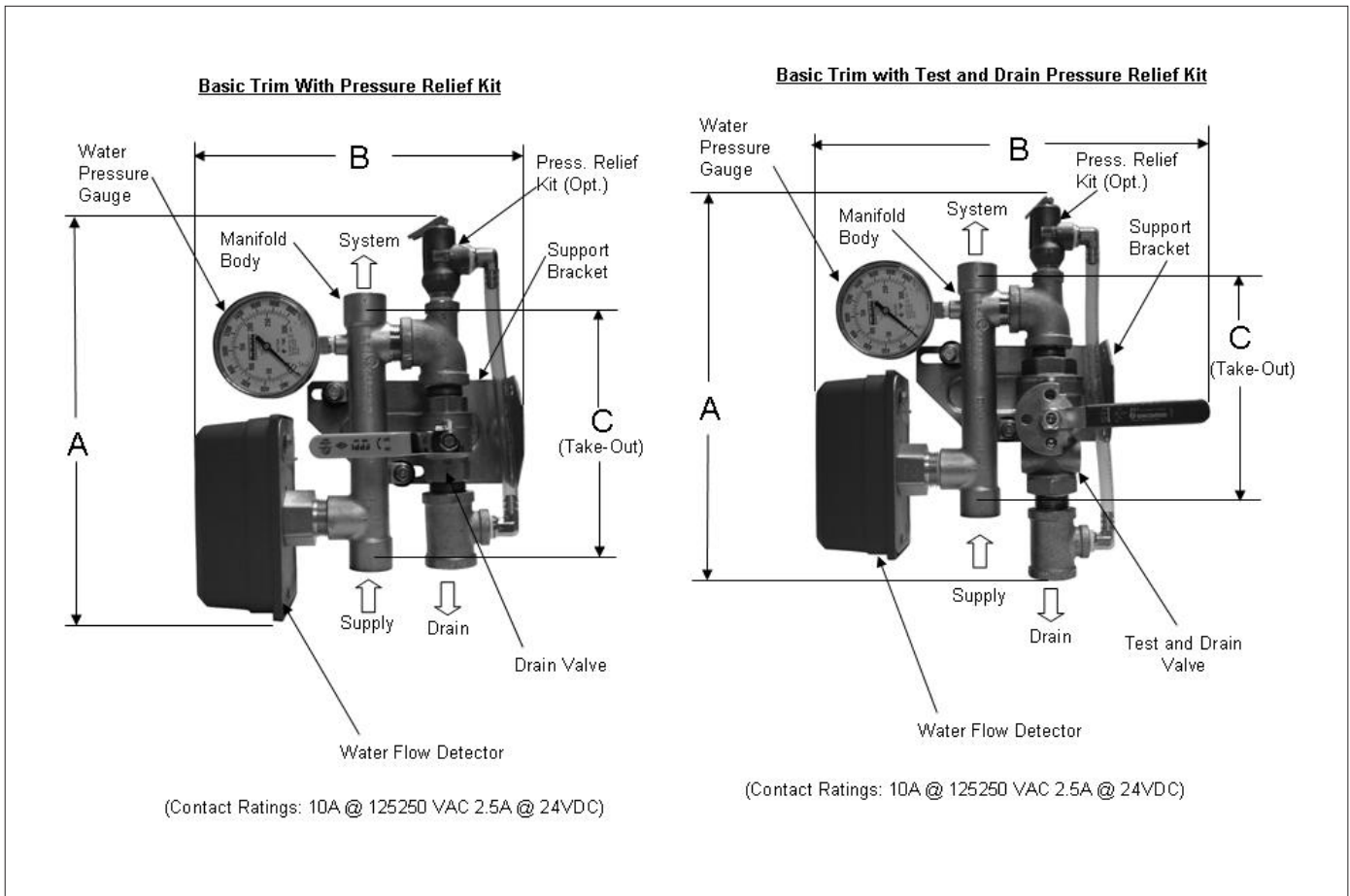

Fig. 5

Product Description:

The Reliable-Risers come factory assembled with all of the necessary accessories for a cost effective, yet complete riser solution.

Reliable-Risers are [UL Listed][ULC Listed] [NYC Approved MEA 258-93-E] for horizontal or vertical installations as a one-piece, factory assembled unit for use in NFPA 13D and 13R residential systems. The riser manifold assembly shall consist of a (choose one):

- 1" (25 mm) cast, non-welded stainless steel body with 1" female NPT or ISO7-Rc1-11 threaded end connections.

- 1- $\frac{1}{2}$ " (40 mm) cast, non-welded stainless steel body with 1- $\frac{1}{2}$ " female NPT or ISO7-Rc1.5-11 threaded end connections.
- 2" (50 mm) cast, non-welded, stainless steel body with 2" female NPT or ISO7-Rc2-11 threaded end connections.

All of these manifold sizes have cast-on lettering that clearly identifies the manifold's pipe size, flow direction, UL Listing/ ULC Listing, and the test and drain outlet. A built-in drain port is included to permit hydrostatic testing without draining the system. The assembly has a working pressure rating of 175

psi (12.1 bar). Cast-in mounting holes are provided for recessed or flush mounting to a wall. For stud mounting, a support bracket is available that is specifically designed for the cast mounting holes.

All of the trim variations include brass components, a cULus Listed 300 psi water pressure gauge, and a 250 psi UL Listed/ ULC Listed Waterflow Detector. This Waterflow Detector comes factory installed with a weatherproof (outside) cover.

Trim Descriptions

• **Basic Trim**

Residential riser manifold assembly trim shall include a cULus Listed pressure gauge, a drain valve, and dedicated waterflow detector containing two sets of SPDT (Form C) contacts, having an electrical rating of 10A @ 125/250 VAC/2.5 A @ 24 VDC. Triggering flow rate is 4(15) GPM(LPM) to 10(38) GPM(LPM).

• **Basic Trim with Pressure Relief Kit**

Residential riser manifold assembly trim shall include a cULus Listed pressure gauge, a drain valve, and dedicated waterflow detector containing two sets of SPDT (Form C) contacts, having an electrical rating of 10A @ 125/250 VAC/2.5 A @ 24 VDC. Triggering flow rate is 4(15) GPM(LPM) to 10(38) GPM(LPM). Pressure relief valve kit shall be provided to maintain system pressures below 175 psi (12.1 bar).

• **Basic Trim with Test and Drain Valve**

Residential riser manifold assembly trim shall include a cULus Listed pressure gauge, a Test and Drain valve, and a dedicated waterflow detector containing two sets of SPDT (Form C) contacts, having an electrical rating of 10A @ 125/250 VAC/2.5 A @ 24 VDC. Triggering flow rate is 4(15) GPM(LPM) to 10(38) GPM(LPM). The test orifice size for the Test and Drain assembly shall be**

****(Choose one)**

- 3/8" (10 mm)
- 7/16" (11 mm)
- 1/2" (15 mm)

• **Basic Trim with Test and Drain Valve & Pressure Relief Kit**

Residential riser manifold assembly trim shall include a cULus Listed pressure gauge, a Test and Drain valve, and a dedicated

waterflow detector containing two sets of SPDT (Form C) contacts, having an electrical rating of 10A @ 125/250 VAC/2.5 A @ 24 VDC. Triggering flow rate is 4(15) GPM(LPM) to 10(38) GPM(LPM). Pressure Relief Kit shall be provided to maintain system pressures below 175 psi (12,1 bar).

Installation:

1. Install the manifold with the flow arrow pointing towards SYSTEM side using threaded connections.
2. Connect a 1" NPT drain line. Ensure the drain Ball Valve is in the CLOSED position.
3. Place the sprinkler system in service.

Caution:

Automatic sprinkler systems having non-fire protection connection (permitting continual water flow) require dielectric fittings, according to NFPA 13 sect. 4-6, when dissimilar metal piping materials are joined.

Note:

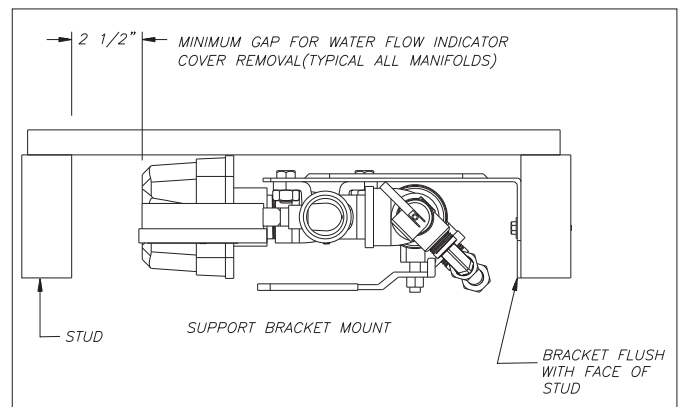

Fig.6

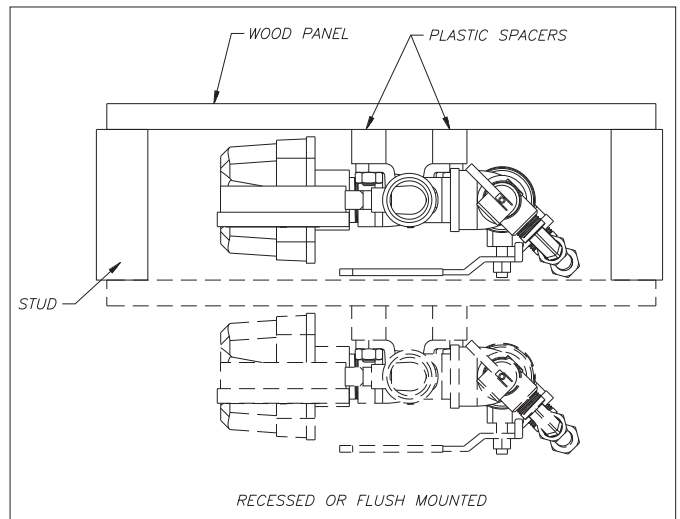

Fig.7

Ordering Information:

Residential Riser Part Number Code Key

1N
1M
1.5N
1.5M
2N
2M
1N = 1" (25mm) NPT Threaded Ends Assembly
1M = 1" (25mm) Metric Threaded Ends Assembly
1.5N = 1-1/2" (40mm) NPT Threaded Ends Assembly
1.5M = 1-1/2" (40mm) Metric Threaded Ends Assembly
2N = 2" (50mm) NPT Threaded Ends Assembly
2M = 2" (50mm) Metric Threaded Ends Assembly

B
T38
T716
T12
B = Basic Trim Assembly
T12 = Basic Trim Assembly with 1/2" (15mm) Orif. Test and Drain Valve

0
1
2
3
0 = Assembly without Pressure Relief Kit Water Detector - UL & FM Approved
1 = Assembly with Pressure Relief Kit Water Detector - UL & FM Approved
2 = Assembly without Pressure Relief Kit Water Flow Detector - ULC Approved
3 = Assembly with Pressure Relief Kit Water Flow Detector - ULC Approved

Example #1: 1.5N – B – 1

(1-1/2" (40mm) Residential Riser Assembly with NPT Female Inlet and Outlet Threads, Basic Trim with installed Pressure Relief Kit).

Example #2: 2M – T12 – 0

(2" (50mm) Residential Riser Assembly with Metric Female Inlet and Outlet Threads, Basic Trim with Test and Drain Valve having a 1/2" Diameter Test Orifice.)

Also, If Required:

Description	Part Number
Pressure Relief Kit (For Basic Trim)	98020076
Pressure Relief Kit (For Basic Trim with Test and Drain Valve)	6501203551
Support Bracket Kit	6899190001
Waterflow Detector (RFDTH)	96556910
Waterflow Detector ULC (RFDTHA)	96556914
Paddle Tree - Waterflow Detector	96556911

The equipment presented in this bulletin is to be installed in accordance with the latest pertinent Standards of the National Fire Protection Association, Factory Mutual Research Corporation, or other similar organizations and also with the provisions of governmental codes or ordinances whenever applicable.

Products manufactured and distributed by Reliable have been protecting life and property for over 80 years, and are installed and serviced by the most highly qualified and reputable sprinkler contractors located throughout the United States, Canada and foreign countries.

Manufactured by



The Reliable Automatic Sprinkler Co., Inc.

(800) 431-1588
 (800) 848-6051
 (914) 829-2042
 www.reliablesprinkler.com

Sales Offices
 Sales Fax
 Corporate Offices
 Internet Address



Revision lines indicate updated or new data
 E.G. Printed in USA 08/09 P/N9999970348