

Reliable®

Model E3 High Pressure Alarm Check Valve

Instructions for Installation, Operation, Care and Maintenance

4" (100mm), 6" (150mm) and
165mm and 8" (200mm)
Sizes With Model E3 Trim

Listed by Underwriters Laboratories, Inc. Approved
by Factory Mutual Research Corporation, and other
fire insurance and government agencies in the United
States and foreign countries.

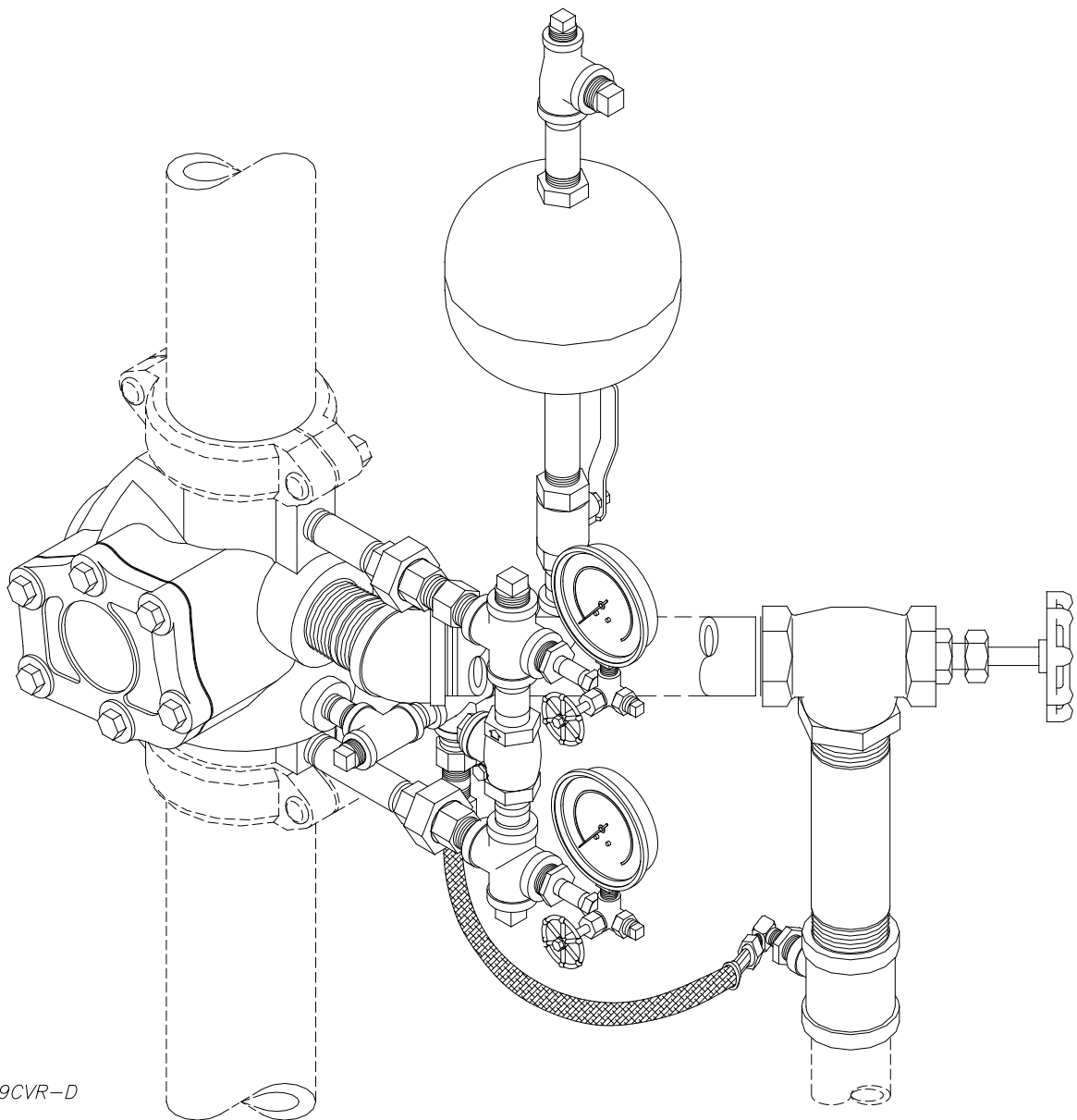

409CVR-D

General

The Reliable Model E3 High Pressure Alarm Valves are available in two easy to install closed drain trims, Standard and Optional (Variable pressure, open drain and pressure relief kits are available). The Optional trim provides a "Test" and "Drain" feature that allows the valve and in certain cases the system alarm devices, to be tested with flow through a calibrated 1/2" orifice. This method of test simulates a fire scenario where one head has opened. It also has the added benefit of exercising the clapper and flushing the alarm porting. (Note: for FM insured applications the placement of a test and drain valve in the trim does not replace the need for an inspector test connection at the outer reaches of the system. See "Test" section for details.) The Standard trim is a low cost alternative to the Optional trim and where as it does not provide the calibrated orifice like the Optional trim its method of testing the alarm devices is similar and provides the same benefits. Both trims are available in vertical or horizontal configurations. Variable pressure water supply requires the use of Model E3 trim and a Reliable E1 Retard Chamber. Constant pressure water supply requires the use of a Model E3 trim set only. Model E3 High Pressure Alarm Valves are shipped with the designated trim set, i.e. variable or constant pressure. All trim sets are closed drain.

The E3 trim is also approved for use in the vertical and horizontal position with the Reliable Model E Alarm Valve which is rated for 175 psi (12 bar) applications.

Valve Description

1. Rated working pressure 300 psi (20,7 bar).
2. Factory hydrostatic test pressure 600 psi (41,4 bar).
3. End and trim connections:
 - Groove dimensions per ANSI/AWWA C606.
 - Threaded openings per ANSI B 2.1. or ISO 7/1R
 - Reliable's standard trim sets are compatible with all 4" (100mm), 6" (150mm) and 8" (200mm) valve sizes.
4. Color – Black
 - Red (E3A *)
 - Blue (Metric)

Groove Dimensions in Inches (mm)					
Valve Size	Inlet and Outlet Dia.	Groove Dia.	Groove Width	Face To Groove Dim.	Valve Type
4 (100)	4.500 (114)	4.334 (110.1)	3/8 (9.5)	5/8 (16)	E3 & E3A*
6 (150)	6.625 (168)	6.455 (164.0)	3/8 (9.5)	5/8 (16)	E3
6 (165)	6.500 (165)	6.330 (160.8)	3/8 (9.5)	5/8 (16)	E3A
8 (200)	8.625 (219)	8.441 (214.0)	3/4 (11.11)	3/4 (19)	E3 & E3A*

*"A" Designates valves made for Australia.

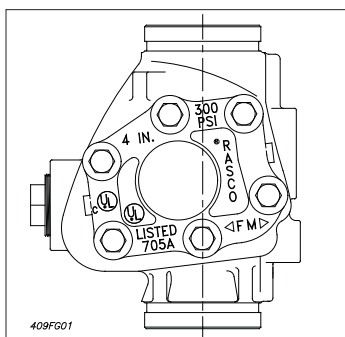

Figure 1

5. Face to Face Dimension:
 - For the 4" (100mm) valve – 11¾" (299mm).
 - For the 6" (150mm) valve – 13½" (343mm).
 - For the 8" (200mm) valve – 14½" (368mm).
6. Friction Loss – Expressed in equivalent length of pipe, based on Hazen-Williams formula with C=120 and a flowing velocity of 15 ft/s (4.6 m/s):

Equiv. Length

- For the 4" (100mm) valve 17' (5.18m)
- For the 6" (150mm) valve 27' (8.23m)
- For the 8" (200mm) valve 29' (8.84m)

Trim Description

The basic trims of the Reliable Model E3 High Pressure Alarm Valve (Figure 2) are arranged for rapid, easy and compact attachment. They serve as a connecting point to Reliable alarm and other devices. The trims also serve as a means for testing the operation of the alarm devices while exercising the alarm valve clapper. Two Model E3 High Pressure trim sets are available for use with the Model E3 High Pressure Alarm Valve. These trims come standard with 0 to 300 psi gauges for 175 psi applications. For 300 psi applications the 0 - 600 psi gauge kit must be ordered. Note: Due to changing Approval agency requirements, the gauges supplied with the 300 psi kit may not be listed at time of ordering.

• Variable Pressure with Closed Retard Drain

Model E1 Retard Chamber is required.

This trim set is used where water supply pressures vary. The retard chamber and the mechanical sprinkler alarm line are drained through a closed connection to the 2" (50mm) drain line. Only one drain connection is required.

Alarm valves are listed and approved by Underwriters Laboratories, Inc. and Factory Mutual Research Corporation only when used with the valve manufacturer's trim sets.

• Constant Pressure

Retard Chamber is not required.

This trim set is used where water supply pressure does not vary. Automatic draining is provided to drain the mechanical sprinkler alarm line. This drain connection is piped into the 2" (50mm) main drain line.

Assembly of Model E3 Trim

• Variable Pressure Vertical Installation (Figure 2)

The following description is the recommended sequence for installing the trim as illustrated in this bulletin.

1. After the alarm check valve has been installed in the riser, attach Segment "A" in the orientation shown and in a leak tight condition.
2. Insert Segment "B" leak tight. **Note:** Segment "B" is the larger of the two union connections.
3. Install Segment "C" leak tight and orientate as shown by wrenching on the 45 degree elbow.
4. Install Segment "D" leak tight.
5. Attach Segment "E" at the unions. Verify that the arrow on the check valve is pointing to system.
6. Install the gauges.
7. Install Segment "F" leak tight by wrenching on the 2" (50mm) tee. Orientate the tube fitting towards the back of the alarm valve. Connect Item 26 (alarm line drain port) to Item 27 in the drain line using the flex tubing provided (Item 11).

Note: the tubing should be free of kinks. **Note:** An open line drain segment is optional, to be purchased separately, as a replacement to seg. F.

8. Install 3/4" x 5" (20mm x 127mm) long galvanized nipple, Model E1 Retard Chamber and Segment "G" in the orientation shown and in a leak tight condition.
9. Connect appropriate water flow alarm devices.

• **Constant Pressure Vertical Installation (Figure 2)**

Trimmings for this installation follow the same sequence given in Steps 1 through 9 above. The only exception is step 8 where Segment "G" is installed directly into the 3/4" (20mm) shut-off valve in Segment "A".

Note: In all cases, carefully install the check valve in the position shown with the flow arrow pointing in the direction shown.

• **Horizontal Installation (Fig. 5, Fig. 6 Fig. 8)**

Follow a sequence similar to that given above for vertical installation, and refer to Figs. 5 & 6 for illustration.

Variable Pressure Equipment

The normal position of the alarm valve parts is shown in Fig. 9. Flow of water in the system piping resulting from the discharge through one or more fused automatic sprinklers causes the Clapper (4) to rise off the Grooved Seat (3) and permits water from the supply piping to enter the system.

The movement of Clapper (4) on Hinge Pin (8) uncovers the groove in Seat (3) and allows water to flow through the groove into the Alarm Line Outlet and to the Alarm Line, Fig 5.

Continual flow of water fills the retard chamber and flows to mechanical and/or electric alarms. (For details on mechanical and electric alarms, refer to their individual instruction sheets.) A small amount of water will simultaneously flow into the drain line.

When the water ceases to flow through the Alarm Valve, the Clapper (4) returns to its seat thus stopping the flow of water to the retard chamber. Drain Orifices (Item 9, Fig. 4 &6) allow the retard chamber and alarm line to empty through the drain line (Item 11, Fig. 4 &6).

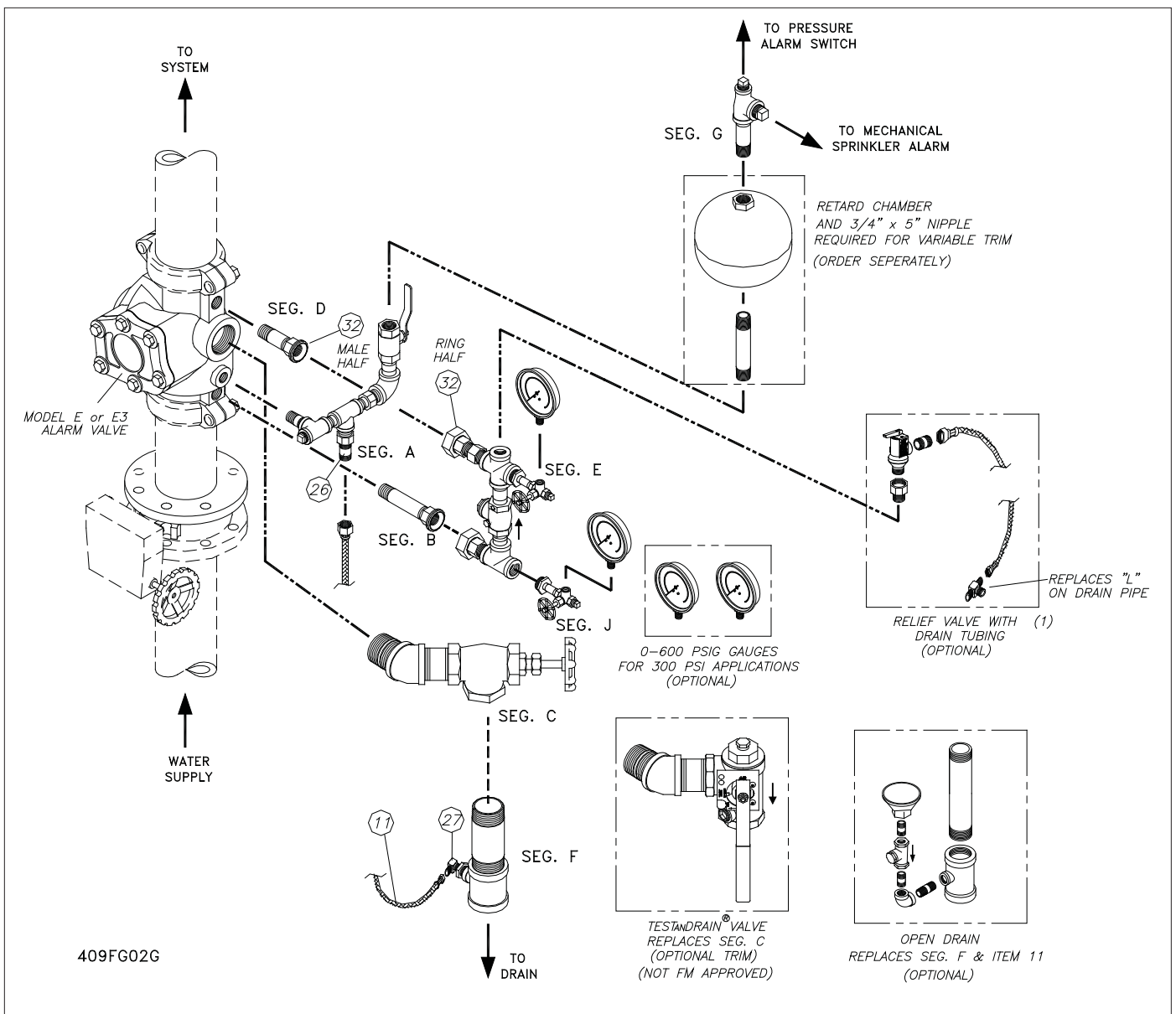

Figure 2 - Model E3 Alarm Valves with Variable Pressure Trim

Variable Pressure (Figures 3 & 5)

Item No.	Part No.		Description	Remarks	No. Req'd
1	6502141415	Vertical	Trim, Model E3 Closed Drain, Seg., 4" & 6" & 165mm		1
	6502141414	Vertical, Optional	Trim, Model E3 Closed Drain, Seg., 4" & 6" & 165mm		1
	6502141418	Horizontal	Trim, Model E3 Closed Drain, Seg., 4" & 6" & 165mm		1
	6502141413	Horizontal, Optional	Trim, Model E3 Closed Drain, Seg., 4" & 6" & 165mm		1
2	6502141436	Vertical	Trim, Model E3 Closed Drain, Seg., 8"		1
	6502141432	Vertical, Optional	Trim, Model E3 Closed Drain, Seg., 8"		1
	6502141438	Horizontal	Trim, Model E3 Closed Drain, Seg., 8"		1
	6502141434	Horizontal, Optional	Trim, Model E3 Closed Drain, Seg., 8"		1
3	6501200115		Retard Chamber		1

Constant Pressure (Figures 4 & 6)

Item No.	Part No.		Description	Remarks	No. Req'd
	6502141415	Vertical	Trim, Model E3 Closed Drain, Seg., 4" & 6" & 165mm		1
	6502141414	Vertical, Optional	Trim, Model E3 Closed Drain, Seg., 4" & 6" & 165mm		1
	650214118	Horizontal	Trim, Model E3 Closed Drain, Seg., 4" & 6" & 165mm		1
	6502141413	Horizontal, Optional	Trim, Model E3 Closed Drain, Seg., 4" & 6" & 165mm		1
	6502141436	Vertical	Trim, Model E3 Closed Drain, Seg., 8"		1
	6502141432	Vertical, Optional	Trim, Model E3 Closed Drain, Seg., 8"		1
	6502141438	Horizontal	Trim, Model E3 Closed Drain, Seg., 8"		1
	6502141434	Horizontal, Optional	Trim, Model E3 Closed Drain, Seg., 8"		1
	6502141414		Trim, Model E3 Closed Drain, Seg., 4" & 6" & 165mm	Items 1 - 36	
1 *	98248001		Gauge, Water Pressure (0 - 300 psi)		2
2	98840180		Valve, Hor. Check, 3/4"		1
3	98840108		Valve, Butterfly, 3/4"		1
4	98840131		Valve, TESTANDRAIN™, 2" Optional		1
	98840100		Valve, Angle, 2"		1
5	98840160		Valve, Gauge, 3-Way, 1/4"		2
6	98614401		Plug, 3/4"		2
7	98614403		Plug, 1/4"		2
8	98604406		Plug, 1/2"		2
9	98580002		Orifice, Drain, 3/16" Orif., 3/4" NPT x 1/2" NPT		2
10	98580006		Orifice, Retard, 3/8" Orif., 3/4" NPT	4" & 6" & 165mm	1
	98580007		Orifice, Retard, 7/16" Orif., 3/4" NPT	8"	1
11	96909925		Flex Line, Steel Braided 3/8" x 9" - Vertical		1
	96920925		Flex Line, Steel Braided 20" LNG - Horizontal		1
12	98761651		Tee, 1/2"		1
13	96606603		Tee, 1/2" x 1/2" x 3/4"		1
14	96606610		Tee, 3/4" x 1/2" x 3/4"		1
15	96606623		Tee, 2" x 2" x 1/2"		1
16	98543238		Nipple, 2" x Close		1
17	98543208		Nipple, 2" x 3" LG.		1
18	98543273		Nipple, 2" x 5 1/2" LG.		1
19	98543212		Nipple, 1/2" x Close		3
20	98543209		Nipple, 1/2" x 2" LG.		1
21	98543226		Nipple, 1/4" x 1 1/2" LG.		2
--	----		----		--
23	98543233		Nipple, 3/4" x 2 1/2" LG.		1
24	98543231		Nipple, 3/4" x 3" LG.		2
25	98543279		Nipple, 3/4" x Close		2
26	92056702	Horizontal	Connector, Male, 3/8" Tubing x 1/4" NPT	See Fig. 6	1
	92056703	Vertical	Elbow, Male, 3/8" Tubing x 1/4" NPT	See Fig. 4	1
27	6502141420	Optional	Open Drain Optional / Kit	See Fig. 2	
	28	98048025		Reducer, Bushing, 1/2" x 1/4"	
29	98048075		Reducer, Bushing, 3/4" x 1/4"		2
30	98174402		Elbow, 3/4"		1
31	98174411	Vertical	Elbow, 2" , 45°	See Fig. 4	1
	98174405	Horizontal	Elbow, 2"	See Fig. 6	
32	98815202		Union, 3/4"		2
33	98543282		Nipple 3/4" x 4" LG.		1
34	98543242		Nipple 3/4" x 5" LG.		2
35	96606601		Tee, 3/4"		1
36	98750005		Cross, 3/4"		1

* For Optional 0 - 600 psi Gauges Specify P/N 98248005

Virtually all sprinkler system piping contains confined air. If a water hammer or pressure surge occurs in the supply line, the increased pressure will compress the confined air and cause the alarm valve clapper to lift intermittently which may result in false alarms.

The Model E3 Alarm Valve minimizes false alarms under these conditions by two features:

1. The Bypass Line, Fig. 7, with Check Valve (B) allows surges to pass from the supply to the system side of the alarm valve clapper without lifting the clapper off its seat. Repeated surges build up an effective excess pressure in the system which steadies the clapper and prevents false alarms. Should a heavy surge force the clapper off its seat and allow water to flow into the alarm line, the Model E1 Retard Chamber comes into action.

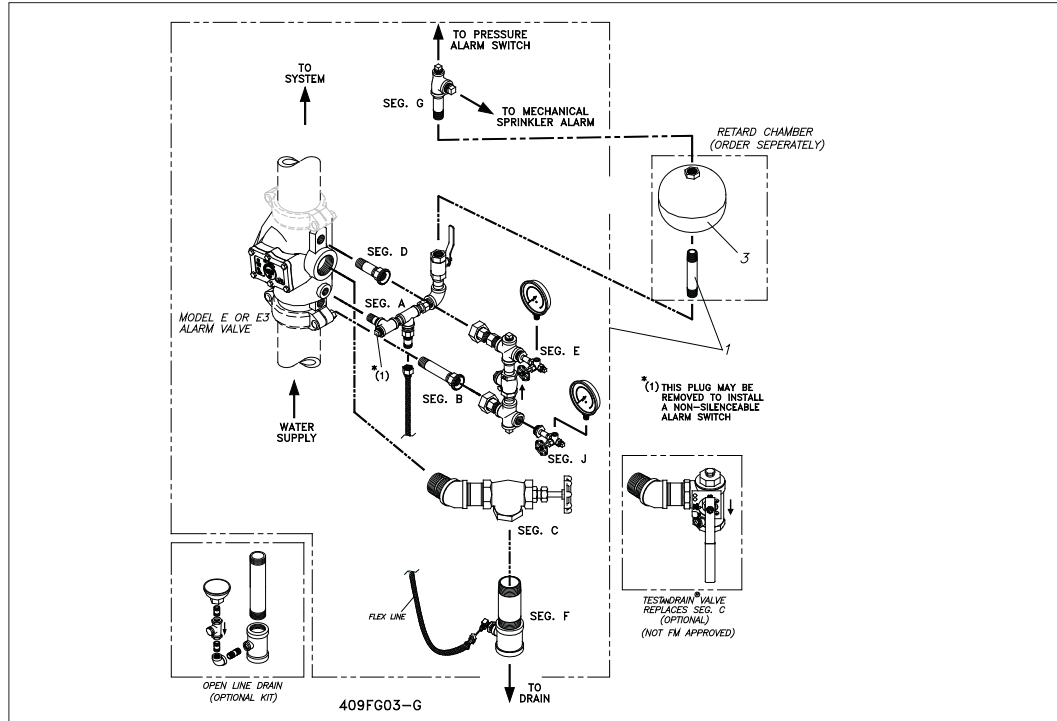

Fig. 3 Variable Pressure Vertical Installation

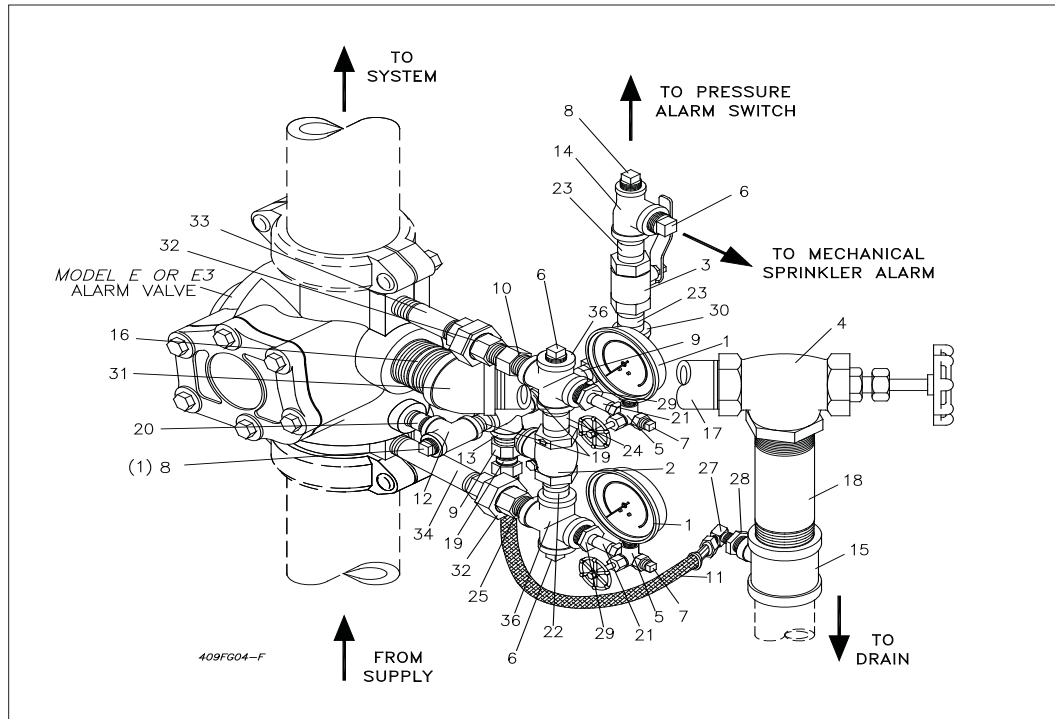

Fig. 4 Constant Pressure Vertical Installation

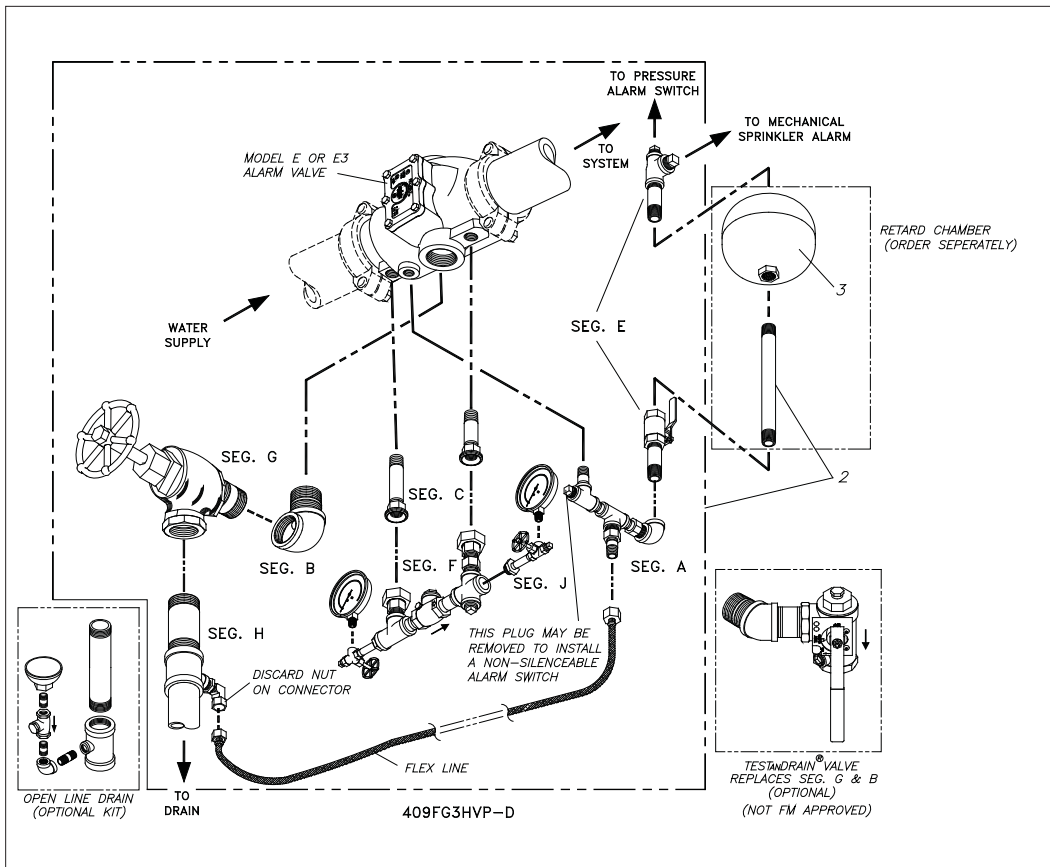

Fig. 5 Variable Pressure Horizontal Installation

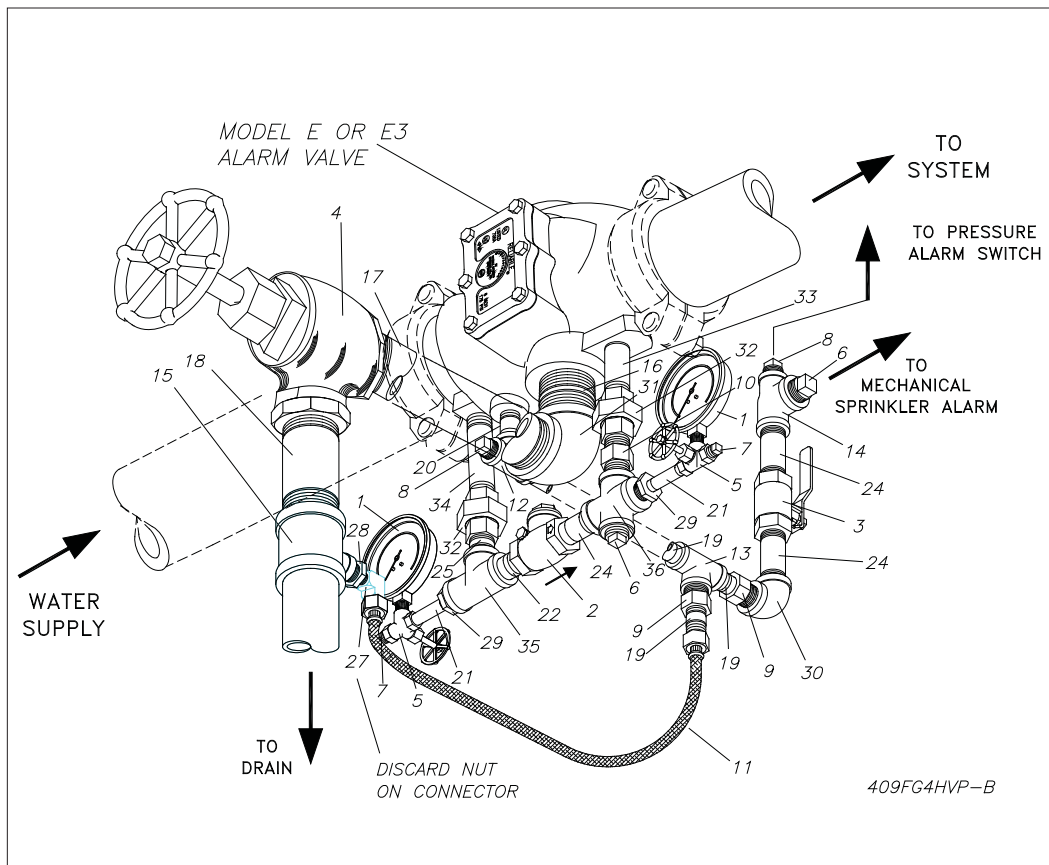

Fig. 6 Constant Pressure Horizontal Installation

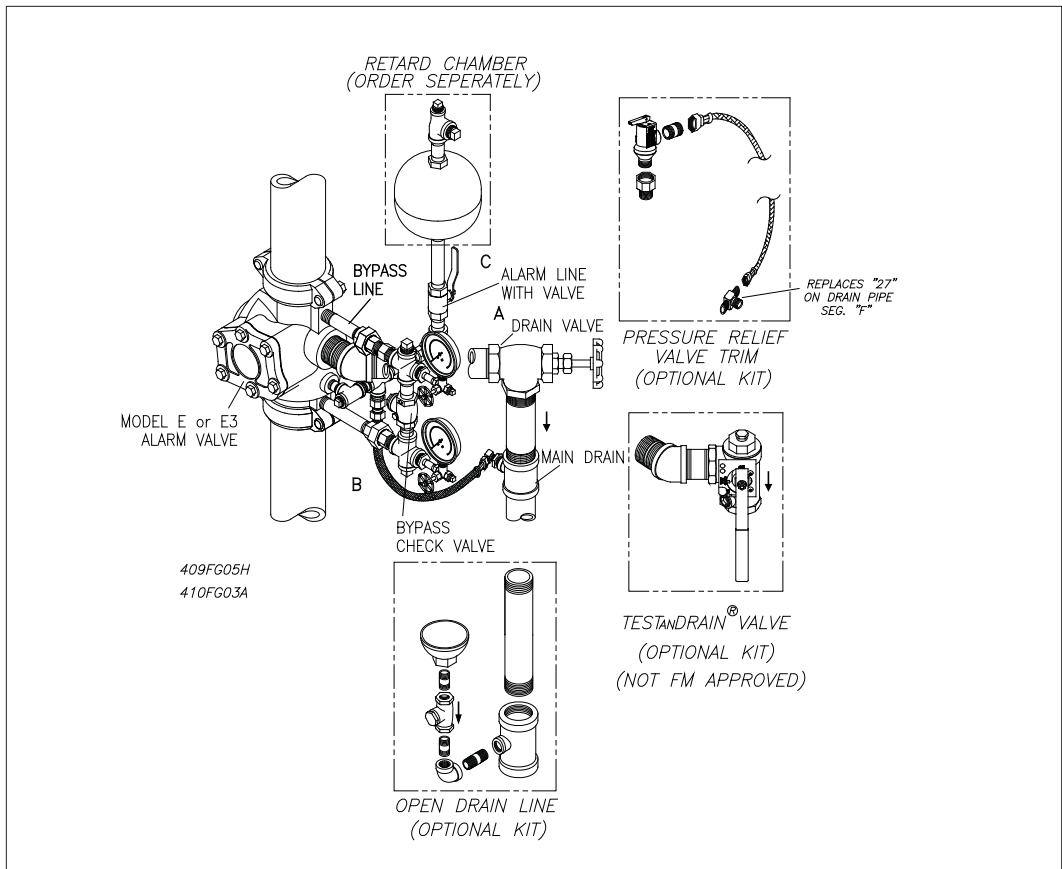

Fig. 7 - E3 Vertical Trim

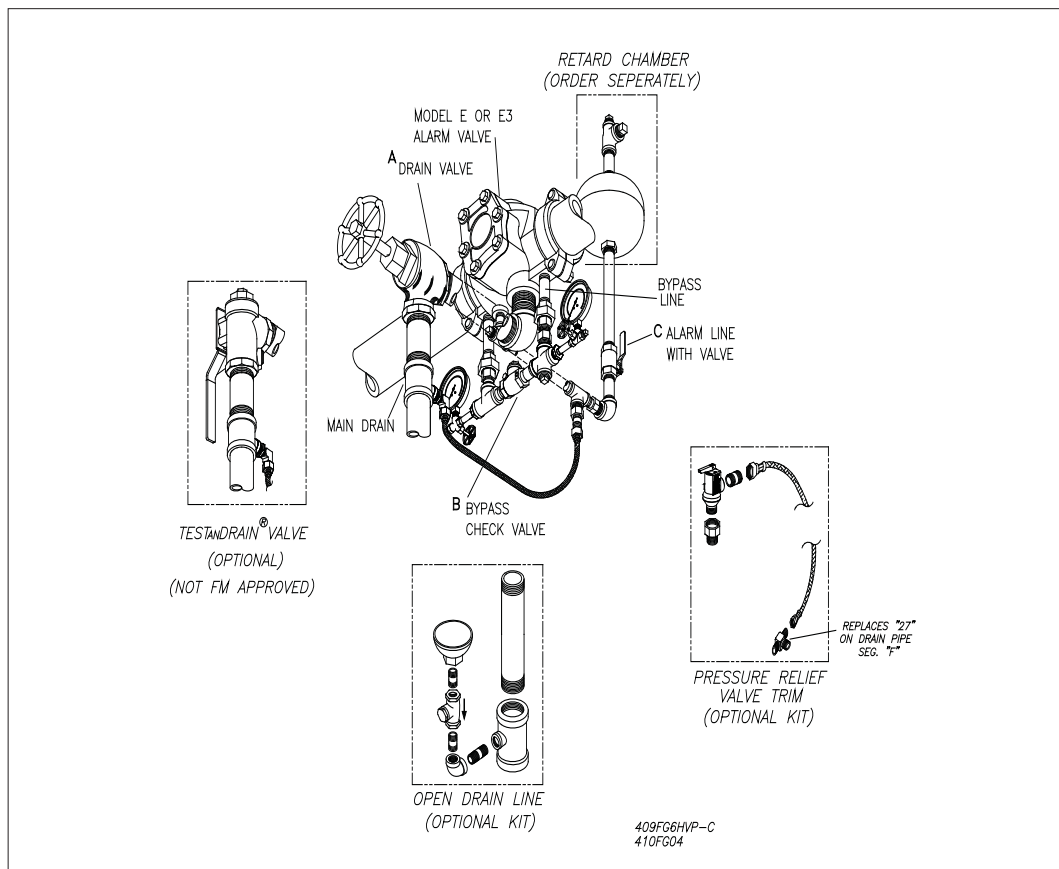

Fig. 8 - E3 Horizontal Trim

2. The retard chamber and the restriction and drain orifices allow intermittent flows to be drained before they can fill the chamber and pass on to operate the electric and mechanical alarms.

Constant Pressure Equipment

The operation of this equipment is the same as described for the variable pressure equipment, except that due to the water supply pressure being constant, the retard chamber is not required. The water, on passing through the groove in the seat of the alarm valve, flows directly to operate the electric and mechanical alarms.

Tests

To test the readiness of the entire wet pipe system, open the inspectors test connection which should cause the mechanical and the electric alarms to sound. This test connection is usually located on the end or top line of the system and its opening is the equivalent to the fusing of one automatic sprinkler.

To test the operation of the alarm equipment only, open Valve (A), Fig. 7, until alarm sounds. For the optional TestANDrain[®] installation kit open the valve to the "Test" position. Testing this way has the added benefit of exercising the clapper assembly. Should the mechanical sprinkler alarm (water motor) not operate, most likely the strainer is clogged. Remove the strainer cap and filter to clean. Be sure to replace the cleaned filter and tighten cap securely. Refer to Bulletin 613 for cleaning information.

To test supply piping for unobstructed flow, close Valve (C), Fig. 5, and open Valve (A) to the drain position. When the test is completed, close Drain Valve (A) securely and open Valve (C) which must be monitored with a suitable supervising device.

For FM insured applications the placement of a Test and Drain valve (E3 Trim Option) in the 2" (50mm) drain line does not replace the need for an inspector's test connection at the outer reaches of the sprinkler system. The drain valve shall not be used in lieu of the inspector's test connection for the testing of the entire wet piping system. The drain valve shall only be used to exercise the clapper and test valve associated alarm devices. For all other applications please refer to NFPA 13 or to the authority having local jurisdiction.

Maintenance

Reliable alarm valves and associated equipment shall periodically be given a thorough inspection and test. NFPA 25 provides minimum inspection, testing and maintenance requirements. Alarm valves shall be tested, operated, cleaned, inspected and parts replaced, as required, at least annually.

Usually, any trouble will be shown by one or more of the following symptoms:

A. Mechanical Sprinkler Alarm (Water Motor) Not Operating.

See **Tests** for corrective measures.

B. Steady Water Flow Into Drain Line

Steps in the following sequence should be taken to correct steady water flow into the drain line:

1. Open Valve (A), Fig. 7, to drain which should flush any loose matter off alarm valve seat. Close valve and observe if water flow ceases.
2. Close main control valve to determine if water flow is coming from above or below alarm valve clapper.

Note: Supply pressure gauge should read zero when main control valve is closed tight and water pressure between this valve and the alarm valve is relieved. If necessary, pressure can be relieved through the lower gauge valve when the 1/4" NPT plug is removed.

- a. If water flow is coming from below clapper, water will stop running to drain line.
- b. If water flow is coming from above clapper, water will continue to run to drain line.

Note: To minimize downtime, the following parts should be on hand before the valve is disassembled:

- 1) Seat installation Wrench:
4" – Part No. 6881240000
6" – Part No. 6881260000
- 2) Clapper Rubber Facing and Clamping Ring Assembly: Item 5, Figure 9.
- 3) Seat "O"-Rings: Items 9 and 10, Figure 9.
- c. In either case (a or b), drain system by opening Valve (A), Fig. 7, to drain. Remove Cover (2), Fig. 9, Shaft Pipe Plug (14), Hinge Pin (8) and Clapper Assembly (4).

Note: Hold down Spring (13) when removing Hinge Pin (8).

- d. Carefully inspect for the following:
 - 1) Damage to clapper rubber facing – Inspect surface for imbedded foreign matter. Replace facing if found damaged (be certain that clapper and clapper clamping ring surfaces are thoroughly cleaned before assembling with new facing.)
 - 2) Damage to seat surface – Clean seat thoroughly. Inspect for any nicks in seat or stones or other foreign matter lodged in seat groove. If seat or other parts of valve are found to be severely damaged, an authorized Reliable distributor should be contacted.
- e. To replace seat "O"-Rings:
 - 1) Using the seat wrench, unscrew the seat. Use care to avoid damage to the seat surface.
 - 2) Remove "O"-Rings, Items 9 and 10, Fig. 9. Thoroughly clean "O"-Ring grooves and sealing surfaces. Inspect for damage or foreign material.
 - 3) Apply a light coat of lubricant to new "O"-Rings and install in the proper grooves. Use care to avoid stretching, twisting or other damage to "O"-Rings.
 - 4) After checking that "O"-Rings are correctly installed, carefully reinstall seat and tighten securely with the seat wrench.
- f. To reassemble alarm valve:
 - 1) Replace clapper assembly (Fig. 6) on seat alarm valve – insert Hinge Pin (8) in valve and pass it through one bearing of Clapper (4) – Press and hold Spring (13) securely in position between clapper alarm bearings and push clapper alarm shaft through spring coils and bushings to far side of valve – Replace Shaft Pipe Plug (14).

Model E3 High Pressure Alarm Valve

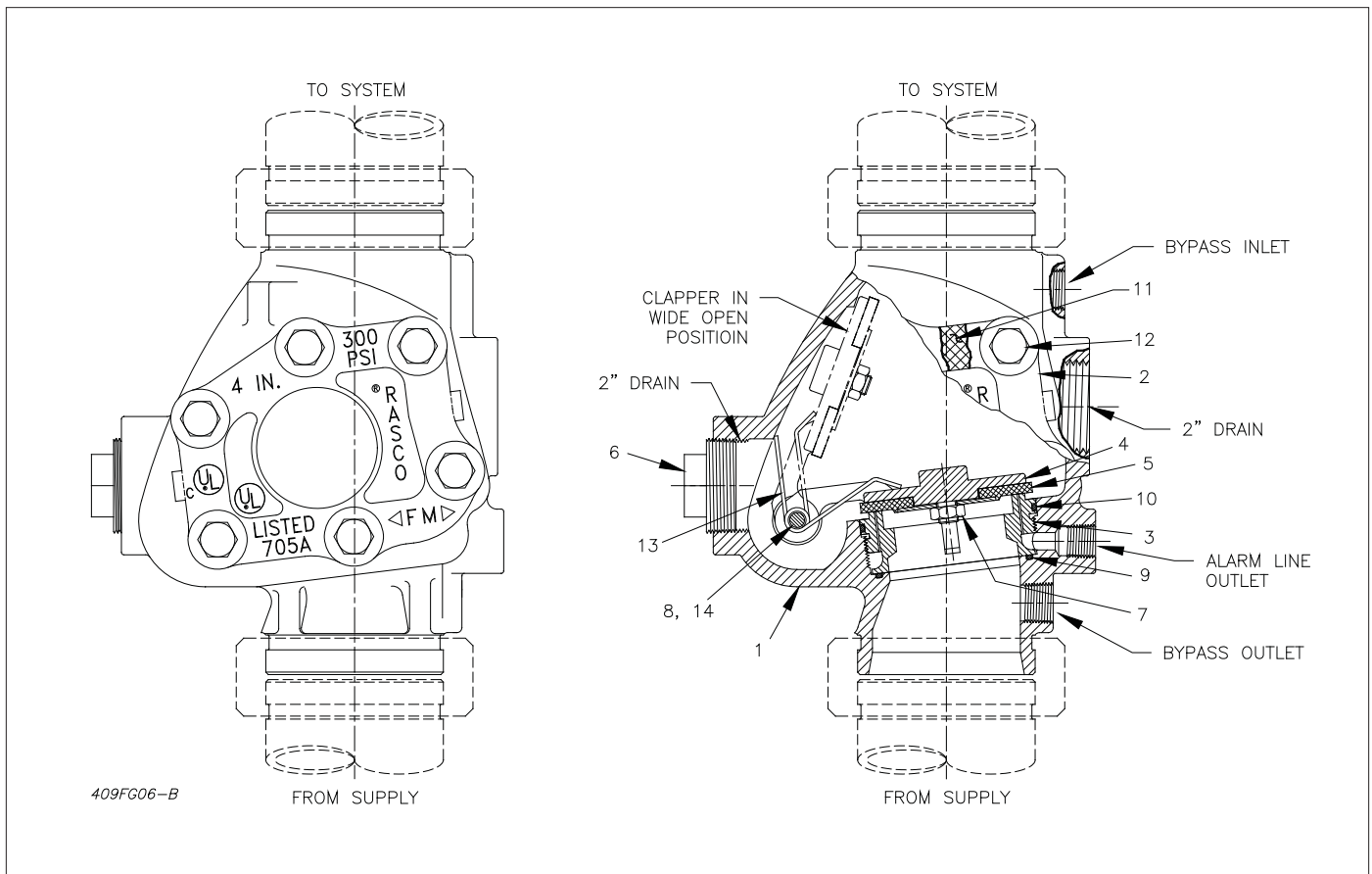

Figure 9

Model E3 Alarm Valve parts

**4" (100mm) - P/N 6102040519; 6" (150mm) - P/N 6102060519
6" (165mm) - P/N 6102065518; 8" (200mm) - P/N 6102080519**

Item No.	Part Name	Part Number				Quantity			
		4" (100mm)	6" (150mm)	6" (165mm)	8" (200mm)	4" (100mm)	6" (150mm)	6" (165mm)	8" (200mm)
1	Body, Grooved x Grooved	91006167	91006165	91006171	91006169	1	1	1	1
2	Cover	92116304	92116306	92116306	92116308	1	1	1	1
3	Seat	96016124	96016126	96016126	96016128	1	1	1	1
4	Clapper Bushing Assy.	71020424	71020626	71020626	71020828	1	1	1	4
5	Clapper Rubber Facing and Clamping Ring Assy.	93416104	93416106	93416106	93416108	1	1	1	
6	Drain Plug (Except Metric Valves)	95206104	95206104	95206104	95206104	1	1	1	
7	Clamping Ring Screws or Nut	94906124	95606126	95606126	95606126	1	4	4	1
8	Hinge Pin	95006124	95006126	95006126	95006128	1	1	1	1
9	Seat "O"-Ring	95436124	95436126	95436126	95436128	1	1	1	1
10	Seat "O"-Ring	95446124	95446126	95446126	95446128	1	1	1	1
11	Cover Gasket	93706124	93706126	93706126	93106128	1	1	1	1
12	Cover Bolts	91106124	91106126	91106126	91106126	6	6	6	6
13	Clapper Spring	96406124	96406124	96406124	96406124	1	1	1	1
14	Shaft Pipe Plug (not shown)	98604402	86044002	86044002	86044002	1	1	1	1
-	Retard Chamber Model E1	6303000522	6303000522	6303000522	6303000522	-	-	-	-

- 2) Lift toe of clapper – check for freedom of rotation and proper seating.
- 3) Replace Cover (2) being sure Cover Gasket (11) is in position and bolts and nuts are securely tightened.
- 4) Close Drain Valve (A), Fig. 7. Slowly open main control valve. Be sure Valve (C) and the main control valve are properly supervised in the OPEN position.

C. False Alarms

False alarms are generally caused by pressure surges in the water supply and can occur if the system loses its effective excess pressure (see "Operation"). Similar readings on the system and supply pressure gauges are a visual indication that the excess pressure condition has been lost. One or more of the following will contribute to this loss of pressure – Leaking system drain valves, leaking at the Alarm Valve Seat (3), Fig. 6, leaking between the Clapper (4) and the Facing (5), or leaking at the Bypass Check Valve (B), Fig. 7.

Corrective Steps:

1. Check system drain valves for tightness.
2. In order to find and correct a leak at the alarm valve seat, proceed as outlined in B.1. through 2.
3. To correct a leak between the clapper and the clapper facing, proceed as outlined in B.2.c. and B.2.d.1.
4. In order to find and correct a leak through the bypass check valve, proceed as follows:
 - a. Close the main control valve and relieve pressure between main control valve and clapper of the alarm valve through the ¼" NPT lower gauge valve. Close this valve before removing the ¼" NPT plug, and open after the plug is removed to relieve pressure. If water continues to flow from this valve, the bypass Check Valve (B) should be cleaned, repaired or replaced.
 - b. If Bypass Check Valve (B) is leaking, repair after opening Valve (A) to drain and draining the system completely.
 - c. Following all repairs, close Valves (A) and then slowly open the main control valve, and supervise it appropriately.
5. If the retard and mechanical sprinkler alarm line does not drain completely, false alarms may result. In this case, check both drain orifices (Item 9, Fig. 4. & 6) to ensure they are not plugged.

D. Intermittent Alarms

Intermittent alarms are the result of excessive confined air trapped in the sprinkler system piping. To correct this problem, fill the system slowly while venting air at all system openings. When the system is fully pressurized, vent air at all system high points including sprinkler connections if necessary.

Contact the installing contractor or Reliable if any difficulties are experienced. Should replacement parts be needed, use only genuine Reliable made parts. When ordering, specify part number, name, size, model and serial number of the unit.

Model E3 Vertical & Horizontal Trim Illustrations
Installation Measurement in Inches (mm)

Valve	A	B	C	D	E	F	G	H	I	J	K	L	M
4 (100)	7 (178)	10½ (267)	16½ (419)	6 (152)	16¾ (426)	15 (381)	3½ (89)	5¾ (146)	12 (305)	4½ (114)	6½ (165)	10 (254)	8¼ (210)
6 (150) (165)	7 (194)	11½ (292)	17½ (445)	7 (178)	15¼ (387)	16½ (419)	4¼ (108)	7 (178)	12 (305)	4½ (114)	6½ (165)	10 (254)	6¾ (172)
8 (200)	7 (194)	11½ (292)	17½ (445)	7 (178)	15¼ (387)	16½ (419)	4¼ (108)	7 (178)	12 (305)	4½ (114)	6½ (165)	10 (254)	6¾ (172)

Vertical Variable Trim - Top View

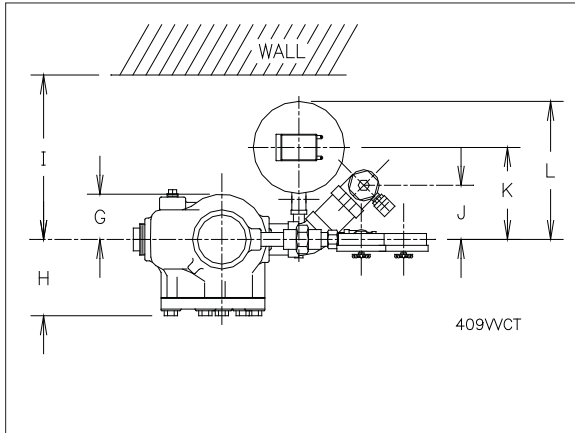

Horizontal Variable Trim - Top View

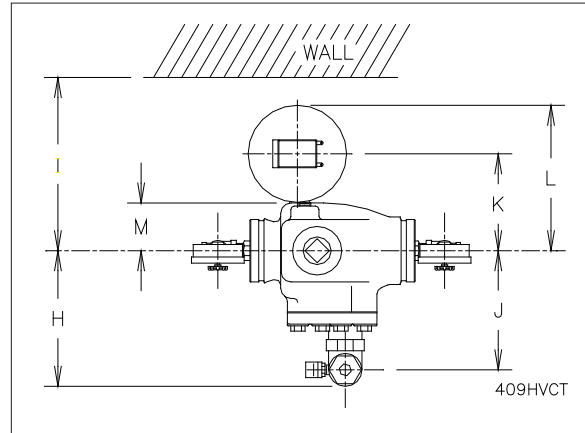

Vertical Variable Trim - Front Elevation

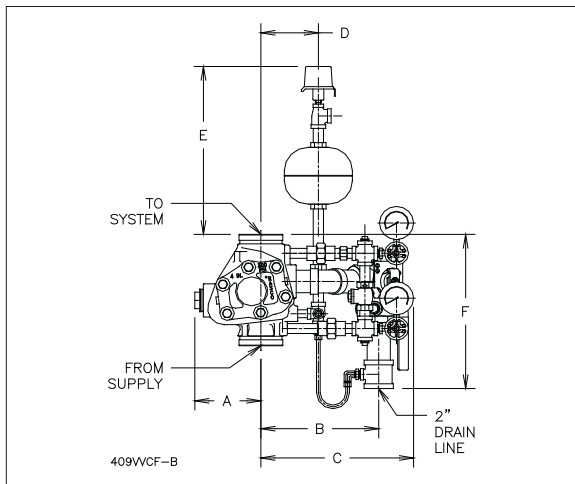

Horizontal Variable Trim - Front Elevation

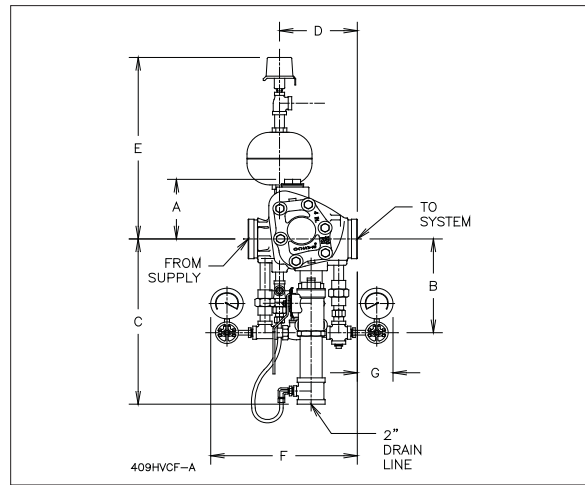

Vertical Constant Trim - Front Elevation

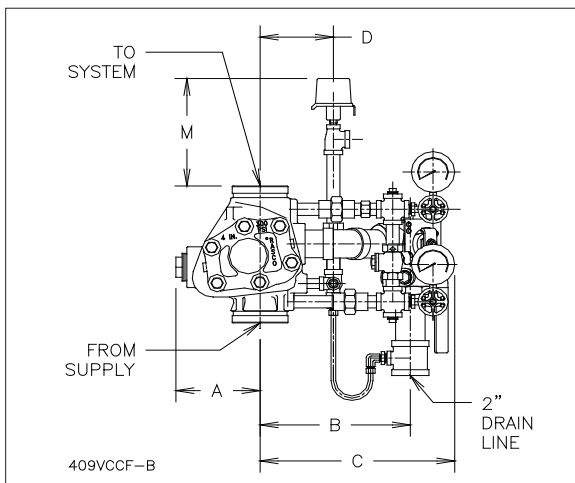

Horizontal Constant Trim - Front Elevation

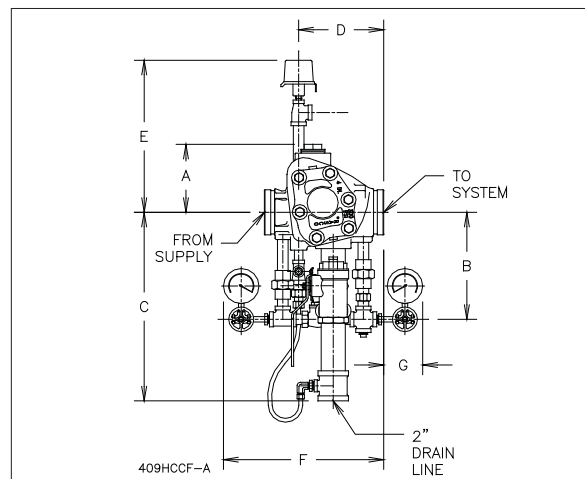

Reliable...For Complete Protection

Reliable offers a wide selection of sprinkler components. Following are some of the many precision-made Reliable products that guard life and property from fire around the clock.

- Automatic sprinklers
- Flush automatic sprinklers
- Recessed automatic sprinklers
- Concealed automatic sprinklers
- Adjustable automatic sprinklers
- Dry automatic sprinklers
- Intermediate level sprinklers
- Open sprinklers
- Spray nozzles
- Alarm valves
- Retarding chambers
- Dry pipe valves
- Accelerators for dry pipe valves
- Mechanical sprinkler alarms
- Electrical sprinkler alarm switches
- Water flow detectors
- Deluge valves
- Detector check valves
- Check valves
- Electrical system
- Sprinkler emergency cabinets
- Sprinkler wrenches
- Sprinkler escutcheons and guards
- Inspectors test connections
- Sight drains
- Ball drips and drum drips
- Control valve seals
- Air maintenance devices
- Air compressors
- Pressure gauges/identification signs
- Fire department connection

The equipment presented in this bulletin is to be installed in accordance with the latest published Standards of the National Fire Protection Association, Factory Mutual Research Corporation, or other similar organizations and also with the provisions of governmental codes or ordinances whenever applicable. Products manufactured and distributed by Reliable have been protecting life and property for over 90 years, and are installed and serviced by the most highly qualified and reputable sprinkler contractors located throughout the United States, Canada and foreign countries.

Manufactured by

Reliable[®]

The Reliable Automatic Sprinkler Co., Inc.
(800) 431-1588 Sales Offices
(800) 848-6051 Sales Fax
(914) 829-2042 Corporate Offices
www.reliablesprinkler.com Internet Address



Revision lines indicate updated or new data.

EG. Printed in U.S.A 08/11 P/N 9999970178