

# Reliable®

## Model DDX-LP Dry Pipe Valve System 8" (200mm)

### Instructions for Installation, Operation, Care and Maintenance

- 8 to 26 PSI (0,6 to 1,8 bar)
- Pneumatic Pressure
- Externally Resettable Clapper
- One Main Drain
- No Priming Water Required

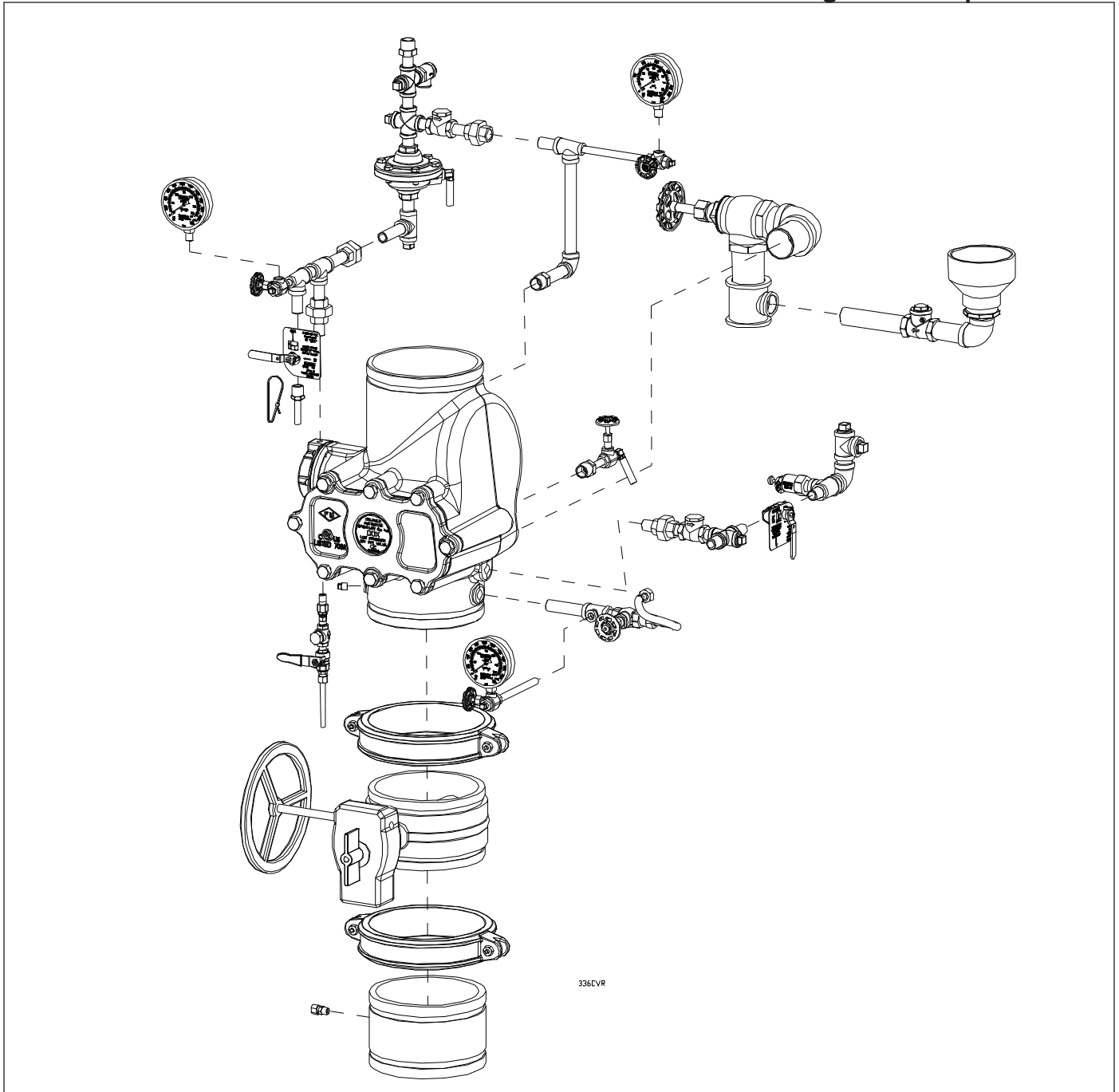

## General

The Reliable Model DDX-LP Dry Pipe Valve is a hydraulically operated, differential latching clapper-type valve (see Fig 1.) designed for use as a primary control valve in a low pressure dry pipe valve system. The trim set used with the Model DDX-LP Dry Pipe Valve contains the Reliable Model LP Dry Valve Actuator releasing device. This Actuator allows the system's air or nitrogen pressure requirement to be considerably less than the available water supply pressure (see Table A). The following benefits are a direct result of lower air pressure:

1. In refrigerated area systems, lower air pressure decreases the possibility of ice plugs, which could impede or prevent the flow of water to sprinkler heads in the event of fire.
2. Lower air pressure (volume) will enable smaller capacity, lower cost dehydration equipment when it is required.
3. Lower air or nitrogen pressure can reduce water delivery time when the system actuates, and in some cases, may eliminate the need for an accelerator.
4. Low pressure requirements make the use of dry nitrogen gas, instead of air, practical even on larger systems. Resulting benefits include a lower-than-air dew point, which minimizes ice plugging of system lines, and enhances "user friendliness" during installation and operation.
5. System maintenance is simplified since priming water is not required and the Dry Pipe Valve can be reset externally without cover removal. This is accomplished by pushing in and turning the external reset knob at the rear of the Dry Pipe Valve (see Fig.1). This feature provides a significant system-restoration time advantage.

The Model DDX-LP Dry Pipe Valve's trim set (see Fig. 2) provides all of the necessary equipment for connections to the pushrod chamber's inlet and outlet ports, the 2" (50mm) main drain, alarm devices, air supply, water supply, and required pressure gauges. This trim set is available in individual parts, in time-saving, segmentally assembled kit forms, or fully assembled to the Model DDX-LP Dry Pipe Valve (with or without a control valve).

All the sizes of the Model DDX-LP Dry Pipe Valve trim sets may be equipped with the optional Reliable Model B1 Accelerator, trim kit P/N 6516000003, (see Figs. 2 & 3). This device acts as an exhauster which will hasten the operation of the Model LDX Dry Valve Actuator and minimize the water delivery time for the entire system.

## Listings & Approvals

Reliable Model DDX-LP Dry Pipe Valves, complete with trim that includes a Model LP Dry Valve Actuator, and only when used as the valve manufacturer's complete system are:

1. Listed by Underwriters Laboratories, Inc. and UL certified for Canada (cULus).
2. Certified by Factory Mutual Approvals (FM).

## System Operation

The Reliable Model DDX-LP Dry Pipe Valve is shown in both closed and open positions in Fig. 1. In the closed position, the supply pressure acts on the underside of the clapper and also on the pushrod through the pushrod chamber's inlet restriction. The resultant force due to the supply pressure acting on the push rod is multiplied by the mechanical advantage of the lever and is more than sufficient to hold the clapper closed against normal supply pressure surges.

When a sprinkler operates, there will be a loss of air or nitrogen pressure in the sprinkler system's piping which will cause the Model LP Dry Valve Actuator to open. The opening of this device allows a releasing discharge of water from the pushrod chamber's outlet connection. Since the pressure cannot be replenished through the inlet restriction as rapidly as it is vented, the pushrod chamber pressure falls instantaneously. When the push rod chamber pressure approaches approximately one-third of the supply pressure, the upward force of the supply pressure acting beneath the clapper overcomes the lever-applied force thereby opening the clapper.

Once the clapper has opened, the lever acts as a latch, preventing the clapper from returning to the closed position. Water from the supply flows through the Dry Pipe Valve into the system piping. Water also flows through the Dry Pipe Valve's alarm outlet to the alarm devices.

After system shutdown, resetting the Model DDX-LP Dry Pipe Valve is quite simple. Doing so only requires pushing in and turning the reset knob at the rear of the valve (see Fig. 1). The external reset feature of the Model DDX-LP Dry Pipe Valve provides a means for simple, economical system testing, which is one essential facet of a good maintenance program. The external reset feature does not, however, eliminate another important facet of good maintenance, namely, periodic cleaning and inspection of the internal valve parts.

In the event that water builds up inside the valve due to condensate from the air supply system or water left inside from valve system testing, a drain is available for venting. After closing the main supply valve, a small valve over the drain cup can be opened slightly until the water inside the valve body and the main pipe column has drained. See the section titled "Draining Excess/Condensate Water From System" in this bulletin for the detailed procedure.

The Model B Hydraulic Manual Emergency Station (see Fig. 4) is also included in the Model DDX-LP Dry Pipe Valve trim set. It consists of an aluminum nameplate mechanically attached to a ball valve. The valve handle in its OFF position is guarded against accidental turning to the ON position (and system discharge) by a nylon cable tie provided with each trim kit. The cable tie is inserted, as shown in Fig. 4, after the system has been restored for operation. The nylon cable tie is designed to allow, in case of an emergency, forceful turning of the valve handle to the ON position. As an alternative to the Model B Hydraulic Manual Emergency Station, the Model A Hydraulic Manual Emergency Pull Box (see Reliable Bulletin 506) is

also available and can be provided as an option.

Whenever ambient temperature conditions are high, the water temperature in the Model DDX-LP Dry Pipe Valve's pushrod chamber could possibly increase, thereby increasing the pressure in the chamber to values exceeding the rated pressure of the system. In an indoor installation where standard room temperatures are exceeded, a pressure relief kit may be needed. Pressure relief kit, P/N 6503050001, can be installed into the pushrod chamber's releasing line to limit the pressure to 175 psi (12,1 bar).

### Hydrostatic Testing of DDX Valves and DDX Systems

As required by NFPA 13, fire sprinkler systems with working pressures up to and including 150 psi are to be hydrostatically tested at a water pressure of 200 psi and maintain that pressure without loss for two hours. Fire sprinkler systems with working pressures above 150 psi are required to be hydrostatically tested at 50 psi above the system working pressure and maintain that pressure without loss for two hours. In addition to the hydrostatic tests described above, dry pipe and double interlock preaction systems require an additional low pressure air test.

In some cases, hydrostatic testing (in accordance with the NFPA 13 requirements noted above) will result in pressures that exceed the working pressure of the valve and trim kit for the two-hour test period. The valve and applicable trim kit have been tested, approved and listed under these conditions and as such, hydrostatic testing in accordance with NFPA 13 is acceptable. In addition, the clapper can remain in the closed position and the trim kit need not be isolated, as each has been designed to withstand hydrostatic testing as required by NFPA 13.

Hydrostatically testing the valve and trim to pressures higher than their rating is limited to the hydrostatic test as referenced by NFPA 13. It does not address the occurrence(s) of a "water hammer" effect, which can indeed damage the valve. A "water hammer" in the water supply piping of the valve can create pressures in excess of the rated pressure and should be avoided by all necessary means. This condition may be created from improper fire pump settings, underground construction work, or an improper venting of trapped air in the water supply piping.

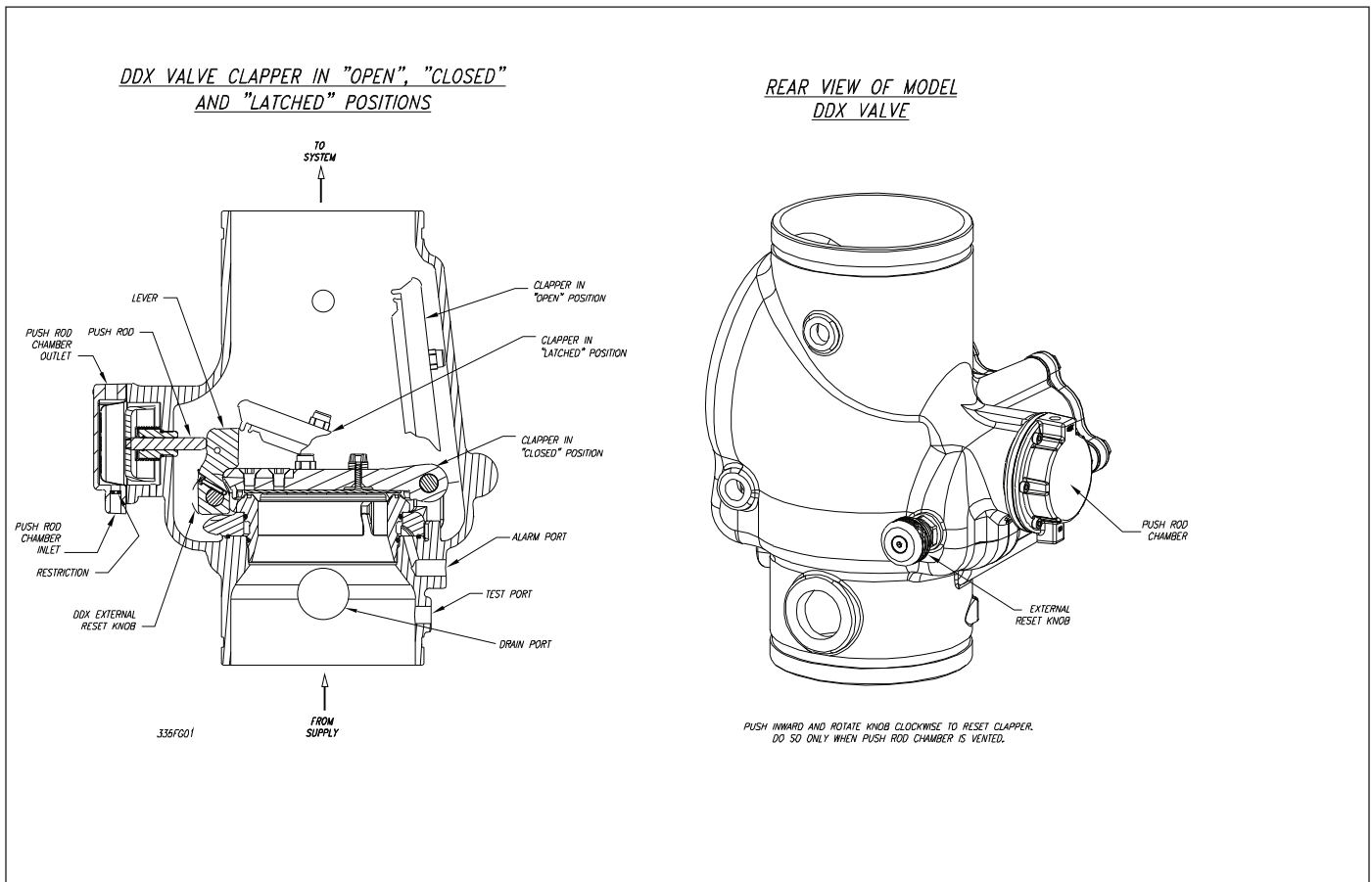

Fig. 1



**Model DDX-LP Dry Pipe Valve System Parts List (Refer to Fig. 2)**

Item No.	Part Number	Description	No. Req'd
1	6215053200	8" UL/FM Butterfly Valve	1
2	6103080001	Assembly, Duluge Dry Valve	1
3	78653000	Assembly, Manual Emergency Station	1
4	78653004	Assembly, Valve Caution Station, 1/2"	1
5	98048015	Bushing, Reducer, 2" Spigot x 1" NPTF, PVC	1
6	98048022	Bushing, Reducer, 3/4" x 1/2", Galv.	2
7	98048025	Bushing, Reducer, 3/4" x 1/4", Galv.	1
8	98840147	Check Valve, 1/4" NPT, Poppet Type Inline	1
9	92056810	Connector, 3/8" I.D. Tube x 1/2" NPT	1
10	92056702	Connector, 3/8" Tubing x 1/4" NPT	2
11	92056704	Connector, Elbow, 3/8" I.D. Tube x 1/2" NPT	1
12	92056705	Connector, Elbow, 3/8" I.D. Tube x 1/4" NPT	1
13	7G05323200	Coupling, Rigid, 8"	2
14	98050004	Drain Cup, PVC	1
15	98174403	Ell, 1", Mall Iron, Galv.	1
16	98174401	Ell, 1/2", Mall Iron, Galv.	1
17	98174405	Ell, 2", Mall Iron, Galv.	1
18	98174402	Ell, 3/4", Mall Iron, Galv.	1
19	96920912	Flex Line, 12"	1
20	98248000	Gauge, Air Pressure (0-80 PSI)	1
21	98248001	Gauge, Water Pressure (0-300 PSI)	2
22	98840172	Globe Valve, 1/4"	1
23	98840181	Horiz. Swing Check Valve, 1/2" NPT	2
24	91004288	Manifold, Supply, 8"	1
25	71030010	Model LP Pilot Line Actuator	1
26	94616916	Nameplate, Dry Pipe Valve	1
27	98543222	Nipple, Steel, Galv., 1" x 3-1/2"	1
28	98543266	Nipple, Steel, Galv., 1" x 6"	1
29	98543213	Nipple, Steel, Galv., 1" x Close	1
30	98543223	Nipple, Steel, Galv., 1/2" x 1-1/2"	13
31	98543216	Nipple, Steel, Galv., 1/2" x 3-1/2"	2
32	98543209	Nipple, Steel, Galv., 1/2" x 2"	7
33	98543230	Nipple, Steel, Galv., 1/2" x 3"	2
34	98543237	Nipple, Steel, Galv., 1/2" x 8"	1
35	98543226	Nipple, Steel, Galv., 1/4" x 1-1/2"	1
36	98543225	Nipple, Steel, Galv., 1/4" x 2-1/2"	1

Item No.	Part Number	Description	No. Req'd
37	98543217	Nipple, Steel, Galv., 1/4" x 6"	2
38	98543262	Nipple, Steel, Galv., 2" x 3-1/2"	2
39	-----	-----	--
40	98543238	Nipple, Steel, Galv., 2" x Close	1
41	98543279	Nipple, Steel, Galv., 3/4" x Close	2
42	99080002	Pad-adhesive	1
43	98750003	Pipe Cross, 1/2", Galv.	3
44	98604406	Plug, Iron, Sq. Hd., 1/2"	4
45	98614403	Plug, Iron, Sq. Hd., 1/4"	4
46	98614401	Plug, Iron, Sq. Hd., 3/4"	2
47	98727607	Strainer, 1/4"	1
48	98840145	Swing Check Valve, 1" NPT	1
49	96606627	Tee, Glvn., 2" x 2" x 1"	1
50	96606607	Tee, Glvn., 1/2" x 1/2" x 1/4"	1
51	98761649	Tee, Glvn., 1/2" x 1/4" x 1/2"	2
52	98761651	Tee, Glvn., 1/2"	2
53	96606612	Tee, Glvn., 3/4" x 1/2" x 1/2"	1
54	96606601	Tee, Glvn., 3/4"	1
55	89141112	Tie, Retaining	9
56	98815204	Union, "O" Ring Seal, Galv., 1/2"	1
57	98815200	Union, 1/2", Iron, G.J., Galv.	3
58	98840160	Valve, 3-way, 1/4"	3
59	98840100	Valve, Angle, 2"	1
60	78653100	Valve, Ball Drip, 1/2"	1
61	98840117	Valve, Ball, 1/4" NPTF x 1/4" NPTM	1
62	98840187	Valve, Check, 1/4" NPTF x 1/4" NPTM	1
63	98840171	Valve, Globe, 1/2"	1
64	98840190	Valve, Relief, 1/2", 40 PSI	1
65	96686722	Tubing, Copper, 3/8" O.D. X 2 Ft.	1
66	96686754	Tubing, PVC, 3/8" I.D. X 6 Ft.	1

## RELIABLE MODEL B1 ACCELERATOR KIT (P/N 651600003)

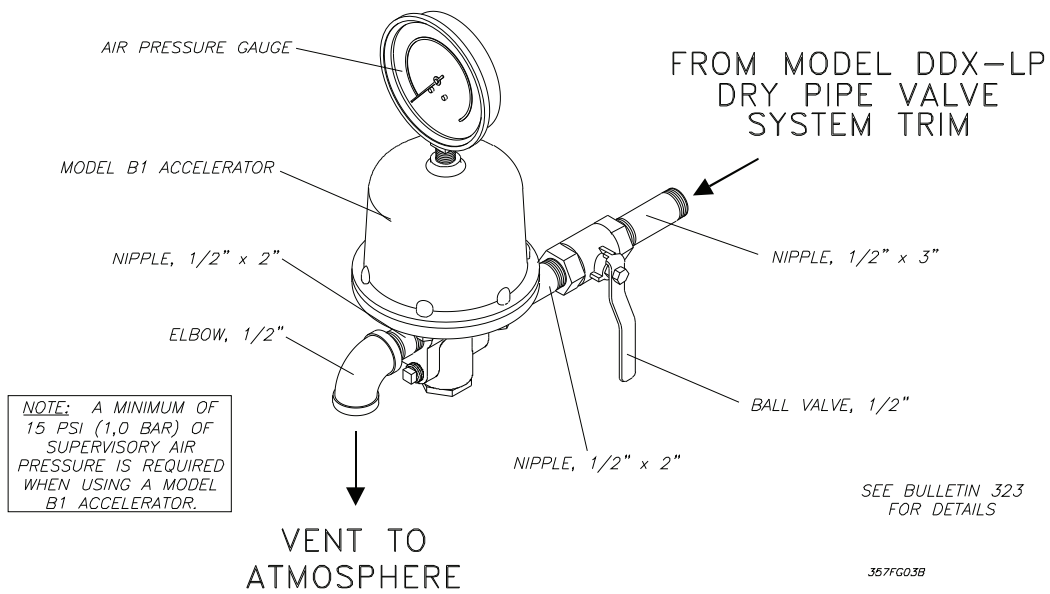

Fig. 3

## MODEL B HYDRAULIC MANUAL EMERGENCY STATION

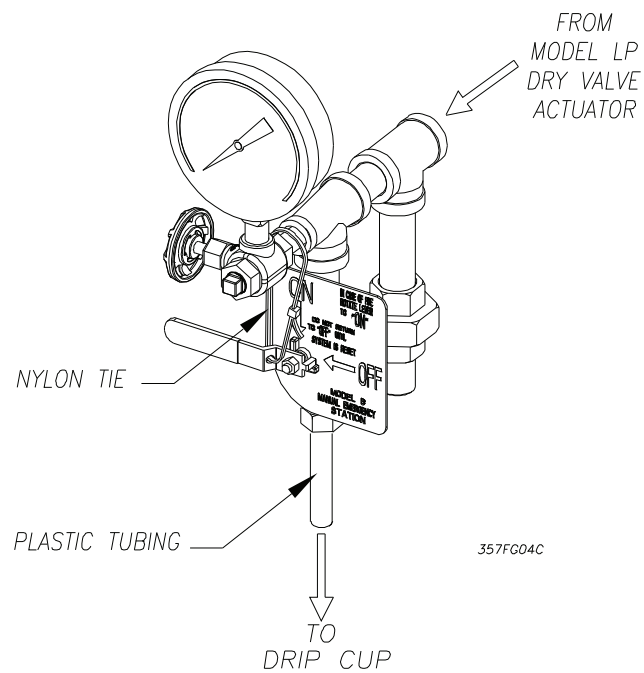

Fig. 4

## **Pressurizing Line Connection**

The water supply for the push-rod chamber must be provided by connection of its inlet pressurizing line to the water supply piping. Pressurizing lines for multiple Model DDX-LP Dry Pipe Valve push-rod chambers must never be manifolded together, having only a single tap on the water supply piping.

Each Model DDX-LP Dry Pipe Valve must have its own push-rod chamber pressurizing line connection. This connection must be made on the supply side of the main water supply control valve. This can be accomplished by:

- a. Using a tapped connection directly below or next to the main water supply control valve using a welded outlet or the appropriate mechanical fittings. A grooved-end outlet coupling is one way to achieve this; or
- b. Using a water supply control valve that has an available threaded (NPT) supply-side tap design to allow for a direct water supply connection to the Model DDX-LP Dry Pipe Valve's push-rod chamber.

**Caution:** Reliable's DDX valve is designed with an inlet restriction built into the pushrod chamber. It is important not to introduce additional restrictions into the direct water supply connection or the discharge from the pushrod chamber by installing additional valves or improperly installing the copper lines used in the trim of the valve.

## **Model DDX-LP Dry Pipe Valve System**

### **Engineering Specifications**

#### **General Description**

Dry pipe sprinkler system shall be a [cULus Listed] [FM Approved] low-pressure dry pipe valve system capable of providing a 17:1 water-to-air force differential. Dry pipe valve shall consist of a lightweight, ductile-iron construction with "screw in" stainless steel seat, and clapper assembly utilizing an intermediate chamber design. Clapper facing shall be pressure-actuated, providing a limited compression seat for the sealing force between the clapper rubber facing and the valve seat. Push-rod chamber shall be of a piston/push-rod design with diaphragm seal and have a ¼" vent hole for air/water leakage indication. Valve end connections shall be grooved outlets per ANSI/AWWA C606. Pneumatic actuation trim shall consist of all galvanized and brass trim, including associated pressure gauges, main drain valve, emergency release valve, and a low-pressure pneumatic actuator valve. The pneumatic actuator shall be cULus Listed/FM Approved for use with the dry pipe valve system. Dry pipe valve system air pressure shall only require between 8 and 26 psi (0,6 to 1,8 bar) for proper setting of the pneumatic actuator in accordance with the manufacturer's instructions. Dry pipe valve shall be of the straight-through design to minimize friction loss, and be capable of being reset without having to remove the valve cover plate through the use of an external reset knob. Dry pipe valve shall actuate through the operation of the pneumatic actuator valve as a result of the loss of system air pressure caused by sprinkler activation. The low-pressure, pneumatic actuator shall be of cast

iron construction utilizing a diaphragm and compression spring design to separate the push-rod chamber water pressure from the system piping's pneumatic supervisory pressure. The low-pressure actuator shall only require between 8 and 26 psi (0,6 to 1,8 bar) supervisory pressure for proper setting in accordance with the manufacturer's instructions. Low-pressure actuator shall be Reliable Model LP Dry Valve Actuator.

Dry pipe valve system shall have a rated working pressure of 250 psi (17,2 bar). Low-pressure dry pipe valve system shall be Reliable [8" (200mm)] Bulletin 336.

## **Pneumatic Pressure Supply Options**

### **Owner's Air supply**

Dry pipe valve system air pressure shall only require between 8 and 26 psi (0,6 to 1,8 bar) for proper setting of the pneumatic actuator in accordance with the manufacturer's instructions. Air supply shall be provided by an owner supplied air system in conjunction with a [cULus Listed] [FM Approved] automatic pressure maintenance device, capable of maintaining a constant system pressure regardless of pressure fluctuations in the compressed air source. The pressure maintenance device shall consist of galvanized trim and brass parts, including a strainer and a field adjustable air pressure regulator, and have a working pressure rating of 175 psi (12,1 bar). The pressure regulator shall have an adjustable outlet pressure range of 5 to 50 psi (0,34 to 3,4 bar). Pressure maintenance device shall be Reliable Model A-2.

### **Compressed Air Supply**

Air supply shall be provided by an automatic tank-mounted air compressor sized for the capacity (volume) of the dry pipe system piping, and be capable of restoring normal air pressure in the system within 30 minutes.

Dry pipe valve system air pressure shall only require between 8 and 26 psi (0,6 to 1,8 bar) for proper setting of the pneumatic actuator in accordance with the manufacturer's instructions. Air supply shall be equipped with an automatic pressure maintenance device capable of maintaining a constant system pressure regardless of pressure fluctuations in the compressed air (or nitrogen) source. The pressure maintenance device shall consist of galvanized trim and brass parts, including a strainer and a field adjustable air pressure regulator, and have a working pressure rating of 175 psi (12,1 bar). The pressure regulator shall have an adjustable outlet pressure range of 5 to 50 psi (0,34 to 3,4 bar). Pressure maintenance device shall be Reliable Model A-2.

### **Nitrogen**

Nitrogen cylinders provided by an approved source shall provide the nitrogen supply. The nitrogen cylinder pressure shall be regulated and supervised through the use of a nitrogen regulating device and low-pressure trim kit. This device shall consist of a brass, single stage pressure regulator, equipped with high pressure inlet and low pressure outlet gauges, and ¼" copper connection tubing with galvanized ¾" x ¼" reducer bushing.

Optional:

Low-pressure trim kit shall be included to monitor the regulated nitrogen supply pressure to provide a low-pressure supervisory alarm. This kit shall include a low-pressure switch with associated galvanized connection trim. Assembly shall be a Reliable Nitrogen Regulating Device. This device is to be used in conjunction with the Reliable Model A-2 pressure maintenance device.

### **Optional System Accessories**

#### **System Control Valve**

Preaction system control valve shall be a slow close, [cULus Listed] [FM Approved] indicating butterfly type valve with a pre-wired supervisory tamper switch assembly. The valve shall be rated for a working pressure of [300 psi (20,7 bar)]. System control valve shall be an [8" (200 mm)] Nibco GD-4765-8N Butterfly Valve.

#### **Accelerator**

For system capacities greater than 500 gallons, an accelerator with associated galvanized trim kit shall be provided to exhaust air pressure from the pneumatic actuator trim piping in order to hasten operation of the dry pipe valve system. Minimum normal air pressure shall be 15 psi (1,0 bar) to ensure proper accelerator operation. Accelerator shall be [cULus Listed] [FM Approved] for use with the specific dry pipe valve system. Accelerator shall be capable of adjusting for small fluctuations in system air pressure without causing operation. The accelerator shall contain an integral Accelo-Check (anti-flooding) assembly to prevent entry of water and debris into critical internal areas during operation. Accelerator body and dome to be of cast aluminum and epoxy coated inside and out. Diaphragm construction to consist of Dupont Fairprene BN 5049 with stainless steel filter assembly. Trim kit shall consist of all galvanized and brass parts, including an isolating ball valve. Accelerator and trim kit shall be Reliable Model B1 Accelerator Trim Kit.

#### **Waterflow Alarm Pressure Switch**

Alarm pressure switch shall be provided to indicate water flow and provide a water flow alarm. Pressure switch shall be [cULus Listed] [FM Approved] and of the bellows activated type enclosed in a weatherproof, 4x, NEMA 4-rated enclosure incorporating tamper-resistant screws. There shall be two sets of SPDT (Form C) contacts rated at 10.0 A @ 125/250 VAC and 2.5 A @ 6/12/24 VDC. The pressure switch shall have a maximum service pressure rating of 250 psi (17,2bar) and shall be factory adjusted to operate at a pressure of 4 to 8 psi (0,27 to 0,55 bar) with adjustment up to 20 psi (1,3 bar). Switch shall be provided with a 1/2" NPT male pressure connection. Waterflow alarm pressure switch shall be System Sensor EPS10-2.

#### **High / Low Air Pressure Switch**

A pressure supervisory alarm switch to monitor the reliability of the compressed air supply shall provide both a high and low-pressure supervisory alarm. Pressure switch shall be [cULus Listed] [FM Approved] and of the bellows-activated type enclosed in a weatherproof, 4x, NEMA 4-

rated enclosure incorporating tamper-resistant screws. There shall be two sets of SPDT (Form C) contacts rated at 10.0 A @ 125/250 VAC and 2.5 A @ 6/12/24 VDC. The pressure switch shall have a maximum service pressure rating of 250 psi (17,2 bar) and an adjustable range of 10 to 100 psi (0,7 to 6,9 bar), factory set to respond at 50 psi (3,5 bar) rising pressure and 30 psi (2,1 bar) at decreasing pressure. Switch shall be provided with a 1/2" NPT male pressure connection. High/Low pressure switch shall be System Sensor EPS40-2.

### **Technical Data**

Reliable Model DDX-LP Dry Pipe Valves, with associated trim, size 8" (200mm) is rated for use at a minimum water supply pressure of 20 psi (1,4 bar) and a maximum water supply pressure of 250 psi (17,2 bar). Water supplied to the inlet of the valve and to the pushrod chamber must be maintained between 40°F (4°C) and 140°F (60°C).

The following list of technical bulletins pertains to valves and devices that may be used in this Dry Pipe Valve system:

Deluge/Dry Pipe Valve	Reliable 514/515
Mechanical Sprinkler Alarm	Reliable 612/613
Pressure Maintenance Device	Reliable 250/251
Nitrogen Regulating Device	Reliable 253
Model B1 Accelerator Trim Kit	Reliable 323
Hydraulic Emergency Station (Model A)	Reliable 506
Low Air Pressure Alarm Switch	System Sensor A05-0177
Waterflow Pressure Alarm Switch	System Sensor A05-0176

### **Model DDX-LP Dry Pipe Valve Description**

1. Rated working pressure:  
Valve & System - 250 psi (17.2 bar).
2. Factory tested to a hydrostatic pressure of 500 psi (34,5 bar). (Valve only)
3. End and trim connections:
  - ANSI/AWWA C606 grooved inlet and outlet

<b>Groove Dimension</b>			
Outlet Diameter	Groove Diameter	Groove Width	Outlet Face to Groove
8.625" (219mm)	8.441" (214mm)	7/16" (11mm)	3/4" (19mm)

- Threaded openings Per ANSI B 2.1
  - Valve Exterior's Color: Black
4. Face to face dimensions:
    - 19 3/8" (492 mm)
  5. Shipping weight:
    - 148 lbs (67.3 kg)
  6. Friction loss (Expressed in equivalent length of Schedule 40 pipe, based on Hazen & Williams formula with C=120 and a flow velocity of 15ft/sec (4.6 m/ sec)):
    - 53.5 ft (16.31 m)
  7. Installation position: Vertical

## System Air / Nitrogen Pressure Requirements

The system trim includes gauges to read the pneumatic and water pressures of Model LP Dry Valve Actuator. Table A specifies the air or nitrogen pressure level to be applied to the Actuator. Optional Reliable Model A-2 Pressure Maintenance Device (see Reliable Bulletins 250 & 251) automatically provides a safeguard against pressure leaks in the sprinkler piping, and properly restricts the flow of makeup air.

When the optional Model B1 Accelerator is used, a Model A-2 Pressure Maintenance Device and a tank-mounted air compressor are required (see Fig. 8). Also, when a Model B1 Accelerator is used, to expedite water-delivery time, the pneumatic pressure must be not less than 15 psi (1,0 bar).

Whenever multiple dry systems are installed at the same location, each dry system is to have its own Model A-2 Pressure Maintenance Device installed for individual maintenance of air pressure (Refer to the 2007 Edition of NFPA 13, section 7.2.6.5.3).

**Table A**

Water Pressure psi (bar)	Pneumatic Pressure to be Pumped into Sprinkler System psi (bar)	
	Maximum	Not Les Than
20 (1.4)	8 (0.6)	10 (0.7)
30 (2.1)	10 (0.7)	14 (1.0)
50 (3.4)	12 (0.8)	16 (1.1)
75 (5.2)	13 (0.9)	17 (1.2)
100 (6.9)	15 (1.0)	19 (1.4)
125 (8.6)	16 (1.1)	20 (1.4)
150 (10.3)	17 (1.2)	21 (1.4)
175 (12.1)	18 (1.2)	22 (1.5)
200 (13.8)	19 (1.3)	23 (1.6)
225 (15.5)	21 (1.4)	25 (1.7)
250 (17.2)	22 (1.5)	26 (1.8)

**Note:** During system set-up, a higher pneumatic pressure may be required in order to properly set the Model LP Dry Valve Actuator. The dew point of the air supply must be maintained below the lowest ambient temperature to which the dry pipe system will be exposed. Otherwise, accumulation of water (condensate) on the air side of the Actuator can lower the air pressure at which the Actuator opens, and possibly prevent proper system operation. Also, introduction of moisture into the system piping exposed to freezing temperatures can create ice blockage, which could prevent proper system operation. As a minimum, the supply of air should be taken from the area of lowest temperature within the protected area. The air supply system must be carefully designed to prevent plugging by frost deposits. Special requirements, such as those in FME&R's "Installation Guidelines for Refrigerated Storage" may need to be incorporated.

Nitrogen used in refrigerated area systems minimizes a possibility of ice build-up and blockage inside the system piping that could inhibit proper system operation. The dew point of nitrogen compressed to 20 psig (1,4bar) pressure is -46°F (-43.3°C), and -52°F (-46.7°C) when compressed

to 10 psig (0,7 bar). High-pressure nitrogen cylinders can typically be rented from a local source, with rental fees varying by supplier and cylinder sizes. Typical cylinders are described in Table B. The calculated nitrogen supply in lbs (kg) to pressurize various system capacities to 10 psi (0,7 bar) at different freezer temperatures is shown in Table C.

**Table B**

Cylinder Size	"Q"	"S"	"K"	"T"
Nitrogen Weight lbs (kg)	5.50 (2.49)	10.28 (4.66)	16.51 (7.49)	22.01 (9.98)
Nitrogen Volume ft <sup>3</sup> (m <sup>3</sup> )	76 (2.2)	142 (4.0)	228 (6.5)	304 (8.6)
Pressurized at psi (bar)*	2200 (151.7)	2200 (151.7)	2200 (151.7)	2460 (169.6)

**Note:** Initial pressure and thus nitrogen weight and volume can vary slightly. Check with your local supplier

**Table C**

System Capacity Gal. (L)	Freezer Temperature, °F (°C)					Approx Fill Time (min*)
	20 (-6.7)	0 (-18)	-20 (-29)	-40 (-40)	60 (-51)	
250 (946)	1.90 (0.86)	1.90 (0.86)	2.00 (0.91)	2.10 (0.95)	2.20 (1.00)	1
500 (1893)	3.64 (1.65)	2.80 (1.27)	4.00 (1.81)	4.20 (1.91)	4.40 (2.00)	2
750 (2839)	5.50 (2.49)	5.70 (2.59)	6.00 (2.72)	6.30 (2.86)	6.60 (2.99)	3
1000 (3785)	7.30 (3.31)	7.60 (3.45)	8.00 (3.63)	8.33 (3.78)	8.80 (3.99)	4

**Note:** To obtain required nitrogen supply (lbs.) for 15 psi (1,0 bar) or 22 psi (1,5 bar), multiply the tabulated values by a factor of 1.5 or 2.2 respectively

(1 bar = 100 kPa)

\* When filled with the Reliable Model A-2 Pressure Maintenance Device having the bypass valve open

## Maintenance

Reliable Model DDX-LP Dry Pipe Valve and associated equipment shall periodically be given a thorough inspection and test. NFPA 25, Inspection, Testing and Maintenance of Water Based Fire Protection Systems, provides minimum maintenance requirements. System components shall be tested, operated, cleaned, and inspected at least annually, and parts replaced as required. Particular attention should be given to the rubber components in the Model B1 Accelerator, Model LP Dry Valve Actuator, and the Model DDX-LP Dry Pipe Valve.

MODEL DDX VALVE 8"(200MM)

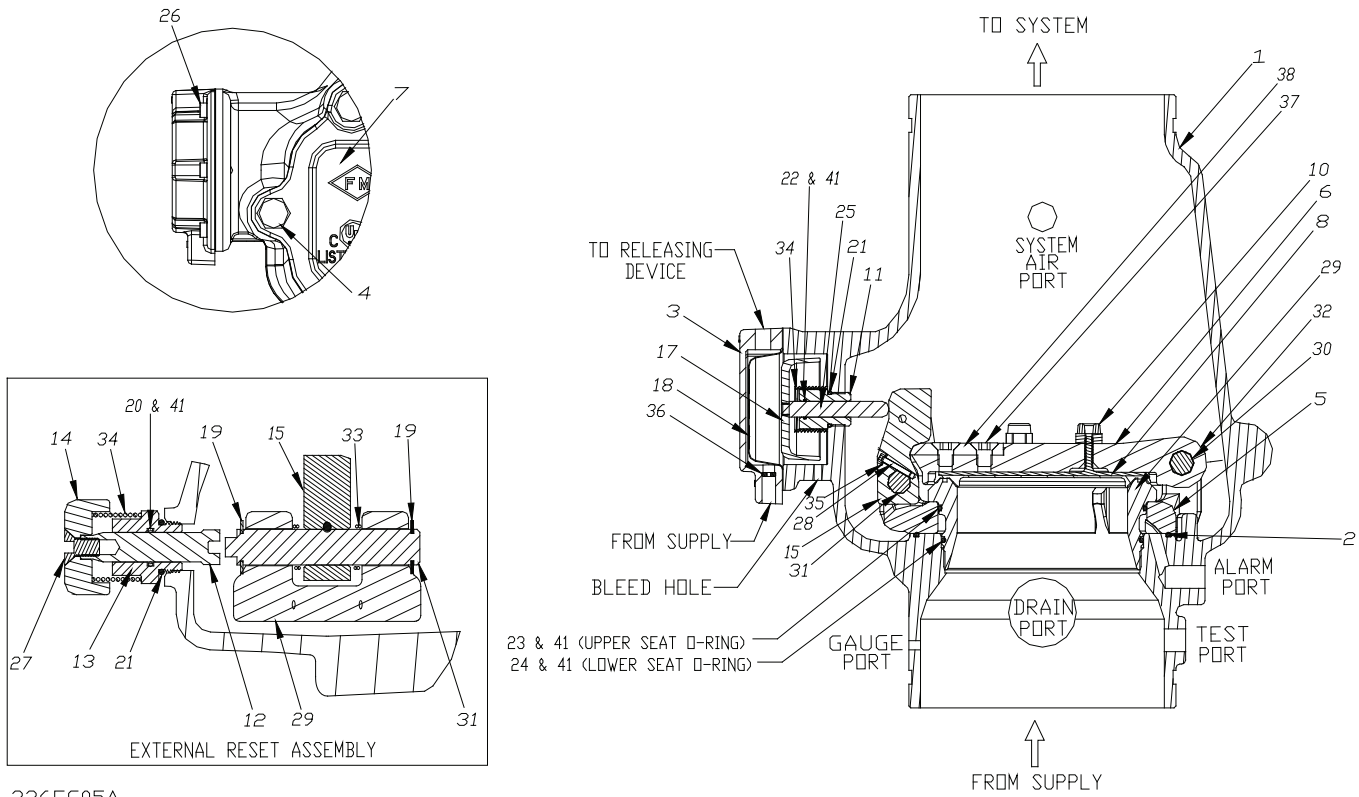

Fig. 5

Item No.	Part Number	Part Description	No. Req'd
1	91006028	Body	1
2	95406414	O-Ring, (266)	1
3	92126006	Cover, Pushrod	1
4	95606110	Screw, Hex Cap, 5/8-11 x 2", ZN PLTD, Grade A	8
5	91306018	Mounting Ring	1
6	91916008	Clapper	1
7	92116068	Cover, Access	1
8	93416008	Seal Assembly	1
9	93706008	Gasket, Access Cover (Not Shown)	1
10	93722000	Bumpstop Assembly	3
11	93916006	Pushrod Guide	1
12	93916066	Shaft, Reset	1
13	94106066	Housing, Reset	1
14	94356006	Knob, Reset	1
15	94506008	Lever	1
16	95006410	Striker, Lever/Clapper	1
17	95106006	Piston	1
18	95276006	Diaphragm	1
19	95316408	Clip, Retaining, 3/4" Shaft, SS	4
20	95406007	O-Ring, (114)	1
21	95406024	O-Ring, (912)	2
22	95406407	O-Ring, (014)	1

Item No.	Part Number	Part Description	No. Req'd
23	95406413	O-Ring, (260)	1
24	95406412	O-Ring, (259)	1
25	95506006	Pushrod	1
26	95606114	Screw, Socket Head, 1/4-20 x 5/8"	6
27	95606127	Screw, Socket Cap, Flat Head, 3/8-16 x 3/4"	1
28	95606130	Screw, Socket Head, #10-23 x 1", SS	1
29	96016008	Seat	1
30	96206008	Pin, Hinge	1
31	96216008	Pin, Lever	1
32	96310008	Spacer, Clapper	2
33	96406008	Spring, Lever	1
34	96406906	Spring, DDX	2
35	96906111	Washer, Spring Lock, #10, SS	1
36	94206406	Inlet Orifice	1
37	95606135	Screw, Socket Cap, Flat Head, 1/2-13 x 3/4", SS	2
38	94616921	Label, Caution, Knob (Not Shown)	1
39	91556922	Ball Chain, 1/8" (Not Shown) (Length in Inches)	6
40	91556923	Clamping Link, Ball Chain, (Not Shown)	1
41	85000050	O-ring Grease, DuPont™ Krytox® GPL-201	A/R

## Resetting the Model DDX-LP

### Dry Pipe Valve System

Refer to Figs. 2, 5, and 6.

1. Close the main valve controlling water supply (Fig. 6) to the Dry Pipe Valve and close off the air/nitrogen supply to the sprinkler system.
2. Close the pushrod chamber supply valve; valve A (Fig. 6).
3. Open the main drain valve, valve B (Fig. 6), and drain system.
4. Open all drain valves and vents at low points throughout the system, closing them when flow of water has stopped. **Note:** The above steps accomplish the relieving of pressure in the pushrod chamber of the Dry Pipe Valve.
5. With valve F (Fig. 6) open, push in the plunger of ball drip valve, valve G (Fig. 6), to force the ball from its seat, and drain any water in the alarm line.
6. With the Model B Manual Emergency Station, Valve D (Fig.6), open, push in and rotate the Model DDX-LP's reset knob (#14, Fig. 5) clockwise until you hear a distinct clicking noise, indicating that the clapper has closed. **Note:** The reset knob can be rotated only while the pushrod chamber is vented to atmospheric conditions (0 psig).
7. Inspect and replace any portion of the sprinkler system subjected to fire conditions.
8. Open valve A (Fig. 6) and allow water to fill the Dry Pipe Valve's pushrod chamber.
9. Bleed all air from the actuation piping by allowing a steady stream of water to flow through the Model B Manual Emergency Station, valve D (Fig. 6). After all trapped air is released; close valve D. Water should still be coming out of the Model LP Dry Valve Actuator (Fig. 6).
10. Close valve F (Fig. 6). Rapidly apply compressed air or nitrogen into the Model LP Dry Valve Actuator and the system until the pressure conforms to Table A levels, as indicated on the air pressure gauge (Fig. 6). **Note:** It may be necessary to temporarily close the main drain valve B (Fig. 6) in order to build sufficient air pressure to "set up" the Model LP Actuator. Once the Model LP Actuator is "set up", the main drain valve B (Fig. 6) should be reopened and the remaining procedure followed. The Model LP Dry Valve Actuator will close during this pressurizing process and the water will stop flowing into the drip cup. At this point, the pressure gauge which indicates push-rod chamber pressure (Fig. 6) will equalize to the available water supply pressure. **Note:** It may be necessary to isolate the system pressure gauge (Fig. 6) in the supply line to the Model LP Dry Valve Actuator during system set-up by closing the 1/4" 3-way valve (#59, Fig. 2). During set-up, pressure fluctuations can occur that are potentially damaging to the gauge. Once the Model LP Dry Valve Actuator is re-set accordingly, the air pressure gauge's 3-way valve (#59, Fig.2) may be re-opened.

11. If it is being used, reset the Model B1 Accelerator per Reliable Bulletin 323. **Note:** The Model B1 Accelerator requires a minimum of 15 psi (1.0 bar) for proper operation.
12. Open Valve F (Fig. 6). Open slightly the main valve controlling water supply (Fig. 6) to the Model DDX-LP Dry Pipe Valve, closing main drain valve B (Fig. 6) when water flows. Observe if water leaks through the ball drip valve, valve G (Fig. 6), into the drip cup, H (Fig. 6). If no leak occurs, the Dry Pipe Valve's clapper is sealed. Open slowly, and verify that the main valve controlling water supply is fully open and properly monitored.
13. Verify that valve A (Fig. 6) and valve F (Fig. 6) are open.
14. Secure the handle of the Model B Manual Emergency Station, valve D (Fig. 6), in the OFF position with a nylon tie (#55, Fig. 2).

### Inspection and Testing

Refer to Figs. 2, 5, and 6.

1. **Water supply**—be sure the valves controlling water supply to the Dry Pipe Valve are open fully and properly monitored.
2. **Alarm line**—be sure that valve F (Fig. 6) is opened and remains in this position.
3. **Other trimming valves** — check that valve A (Fig. 6) is open as well as all of the pressure gauge's 1/4" 3-way valves. Valves D, E, and J (Fig. 6) should be closed.
4. **Ball drip valve G (Fig. 6)**—make sure valve F (Fig. 6) is open. Push in on the plunger to be sure the ball check is off its seat. If no water appears, the Dry Pipe Valve's water seat is tight. Inspect the bleed hole (see Fig. 5) on the underside of the push rod chamber for leakage.
5. **System pneumatic pressure** — check air pressure gauge (Fig. 6) and water supply pressure gauge (Fig. 6) for conformance to Table A.
6. **Model LP Dry Valve Actuator (Fig. 6)** — Verify that the outlet is not leaking water. Check the air pressure gauge (Fig.6) for proper pressure setting. Verify that the tubing line from the Actuator is not pinched or crushed, which could prevent proper operation of the Dry Pipe Valve.
7. **Testing alarms** — make sure valve F (Fig. 6) is open. Open valve J (Fig. 6) permitting water from the supply to flow to the electric sprinkler alarm switch and to the mechanical sprinkler alarm (water motor). After testing, close this valve securely. Push in on the plunger of ball drip valve G (Fig. 6) until all of the water has drained from the alarm line.
8. **Operational test** — Open the Model B Manual Emergency Station, valve D (Fig. 6). Note: An operational test will cause the Dry Pipe Valve to open and flow water into the sprinkler system.
9. Secure Model B Manual Emergency Station, valve D (Fig. 6), in the OFF position with a nylon tie (#55, Fig. 2) after the Dry Pipe Valve is reset

## Testing Model DDX-LP Dry Pipe Valve Without Flowing Water

Refer to Fig. 6

1. Close the main valve controlling water supply to the Dry Pipe Valve.
2. Verify that valve A is open, allowing water to enter the push rod chamber.
3. Close off the air/nitrogen supply to the sprinkler system.
4. Decrease pneumatic pressure in the system by opening the ¼" globe valve, valve E, until the Model LP Dry Valve Actuator operates. This will be indicated by a sudden drop of water pressure on the Dry Pipe Valve's gauges. The operation of the Actuator will vent the push-rod chamber of the Dry Pipe Valve and cause the Valve's clapper to open.
5. To reset the system, close the ¼" globe valve, valve E, and proceed according to the directions listed in the "Resetting Model DDX-LP Dry Pipe Valve System" section of this bulletin.

## Draining Excess/Condensate Water From System

Refer to Fig. 6

1. Close the main valve controlling water supply to Dry Pipe Valve. Also close valve A and open main drain valve, valve B.
2. Open condensate drain valve E until all water has drained. Close valve E when the flow of water (if any) has stopped. Note: Be sure not to keep valve E open for an extended period of time because that will cause enough system air to bleed off thereby actuating the Model LP Dry Valve Actuator (see Table A for pneumatic pressure values required to maintain the Model LP Dry Valve Actuator closed for a given supply pressure). If the Actuator does happen to actuate, proceed according to the directions listed in the "Resetting Model DDX-LP Dry Pipe Valve System" section of this bulletin.
3. Close the main drain valve, valve B. If system contains pressurized air or nitrogen, allow pneumatic pressure to come back up to specification according to Table A. Open valve A first, and then open the main valve controlling water supply to the Dry Pipe Valve.

## Maintenance Procedures – Model DDX-LP Dry Pipe Valve

Refer to Figs. 2, 5, & 6.

### 1. Mechanical sprinkler alarm (water motor—not shown) not operating:

This is most likely caused by a clogged screen in the strainer of the water motor. Proceed as follows: Remove plug from the strainer. Remove and clean the screen. Replace the screen and the plug, and then tighten securely (Ref. Bulletin 613).

### 2. Leakage out of the ball drip valve G (Fig. 6).

#### a. Water leakage due to a water column above the Dry Pipe Valve's clapper:

This condition can be caused by leakage past the system side of the Model DDX-LP Dry Pipe Valve's seal assembly (#8, Fig. 5). Be sure that this surface is free of any type of debris. To eliminate leakage due to a water column, refer to the section in this bulletin marked "Draining Excess/Condensate Water From System". If the problem continues proceed to the following section.

#### b. Leakage, air or water from the ball drip valve, E (Fig. 6):

If system air is leaking out the ball drip valve, the problem is either damage to the air side of the Model DDX Dry Pipe Valve's seal assembly (#8, Fig. 5), seat (#29, Fig. 5), mounting ring O-ring (#2, Fig. 5), or the upper seat O-ring (#23, Fig. 5). If supply water is leaking out the ball drip valve, the problem could be caused by damage to the Model DDX Dry Pipe Valve's seal assembly (#8, Fig. 5), seat (#29, Fig. 5), or lower seat O-ring (#24, Fig. 5). The following section provides instructions to correct both conditions:

- A. Shut down the valve controlling the water supply to the Dry Pipe Valve and open the 2" main drain valve B (Fig. 6). Open the water column drain valve E (Fig. 6). Close the push rod chamber supply valve A (Fig. 6) and open the Model B Manual Emergency Station D (Fig. 6).
- B. Remove the Dry Pipe Valve's front (handhold) cover (#7, Fig. 5) and inspect the seat (#29, Fig. 5), clapper (#6, Fig. 5), and seal assembly (#8, Fig. 5) for damage.

If inspection indicates damage to the assembly (#8, Fig. 5), replace as follows:

Remove the bumpstop nuts (#10, Fig. 5) and remove the seal assembly (#8, Fig. 5). Install a new seal assembly (#8, Fig. 5) and thread the bumpstop nuts (#10, Fig. 5) onto the threaded studs of the seal assembly (#8, Fig. 5) and tighten finger tight plus ¼ to ½ turn.

If inspection indicates damage to the clapper (#6, Fig. 5) only, then the clapper sub-assembly can be removed as follows:

At the rear of the valve, disconnect the water column drain trim section starting with the elbow connector (#12, Fig. 2). Then remove the ¼" globe valve (#22, Fig. 2), followed by the ¾" x ¼" reducing bushing (#7, Fig. 2). Remove the retaining ring (water column drain line side) from the clapper hinge pin (#30, Fig. 5) and push this pin through the handhold cover and remove the clapper subassembly. Replace the seal assembly as described previously. Inspect the clapper (#6, Fig. 5) visually before reinstalling. Reinstall in the reverse order making sure the clapper spac-

ers are in their proper position. If the seat (#29, Fig. 5) is damaged or it is suspected that the leakage is through the lower O-ring (#24, Fig. 5), the seat-clapper subassembly is easily removed as a unit as follows:

Using Reliable P/N 6881608000 Seat Wrench, remove the seat by unscrewing. This will loosen the seat-clapper-mounting ring subassembly. Reach into the valve and grasp the seat and remove it from the valve. Then remove the clapper-mounting ring subassembly from the valve. Visually examine all components of the seat-clapper-mounting ring sub-assembly replacing any component that appears damaged. New O-rings (#23 #24 & #2, Fig. 5) should always be used for reassembly.

#### **Reassembly:**

Clean the bore of the valve body. Lubricate the bore with O-ring grease. Lubricate and install the O-rings (#23 & #24, Fig. 5) onto the seat & O-ring (#2, Fig. 5) into the body (#1, Fig. 5). Insert the clapper-mounting ring sub-assembly into the handhold opening of the Dry Pipe Valve. Align the mounting ring so that the Lever (#15, Fig. 5) is near the pushrod (#25, Fig. 5) and the mounting ring (#5, Fig. 5) "ears" are between the tabs of the valve body (#1, Fig. 5). Insert the seat (#29, Fig.5) into the body and through the clapper-mounting ring subassembly. Start to tread the seat (#29, Fig. 5) into the body by hand, then tighten until the seat (#29, Fig. 5) with seat wrench 6881608000 until it bottoms out on the mounting ring (#5, Fig. 5). Verify that the seat-clapper-mounting ring subassembly is in the fully down position between the tabs of the body, and check to see that the lever (#15, Fig. 5) lines up with the push rod (#25, Fig. 5). Loosen and reassemble if necessary. Reassemble the handhold cover (#7, Fig. 5) and set up the Model DDX Dry Pipe Valve as per the section "Resetting Model DDX Dry Pipe Valve Systems."

### **3. Leakage out of the push rod chamber vent hole:**

A small bleed hole is located on the underside of the push rod chamber (see Fig. 5). If there is air or water leakage coming out of this hole, do the following:

- a. Shut down the valve controlling water supply to the Dry Pipe Valve. Relieve the inlet pressure by opening the 2" drain valve B (Fig. 6). Close the valve A (Fig. 6) that supplies water to the pushrod chamber, and open the Model B Manual Emergency Station, valve D (Fig. 6).
- b. Remove the trim at the unions nearest to the pushrod chamber cover (#3, Fig. 5).
- c. Take the push rod chamber cover (#3, Fig. 5) off by removing the six retaining screws (#26, Fig. 5).

#### **CONDITION ONE (Water coming out of the bleed hole):**

Water coming out of the bleed hole is caused by a leaking diaphragm (#18, Fig. 5). Visually inspect the pushrod chamber cover (#3, Fig. 5) and piston (#17, Fig. 5) to determine what could have damaged the diaphragm and correct. Install a new diaphragm. **NOTE: The diaphragm has two different surfaces. It is not bi-directional. It will fail if installed backwards!** Roll the diaphragm so that the smooth surface (the pressure side) conforms to the inside of the push rod chamber cover and reassemble the six retaining screws (#26, Fig. 5) with an installation torque of 15 foot-pounds. Set up the Model DDX-LP Dry Pipe Valve as per the section "Resetting Model DDX-LP Dry Pipe Valve Systems."

#### **CONDITION TWO (System Air coming out of the bleed hole):**

System air coming out of the bleed hole is caused by a defective O-ring assembled to the push rod guide (#11, Fig. 5). Remove the piston-push rod subassembly, pushrod spring (#34, Fig. 5), and pushrod guide (#11, Fig. 5). Verify by hand turning, that the push rod cannot be unscrewed from the piston. Replace all O-rings and the push rod guide (#21 & #22, Fig. 5). The correct installation torque for the push rod guide is 35 inch-pounds.

**CAUTION: Do not over tighten the pushrod guide.** Reassemble the components that were initially removed. Reinstall the diaphragm (#18, Fig. 5) if it appears to be in good shape, otherwise, replace it also. **NOTE: The diaphragm has two different surfaces. It is not bi-directional. It will fail if installed backwards!** Roll the diaphragm so that the smooth surface (the pressure side) conforms to the inside of the push rod chamber cover and reassemble the six retaining screws (#26, Fig. 5) with an installation torque of 15 foot-pounds. Set up the Model DDX-LP Dry Pipe Valve as per the section "Resetting Model DDX-LP Dry Pipe Valve Systems."



## MODEL LP DRY PILOT LINE ACTUATOR

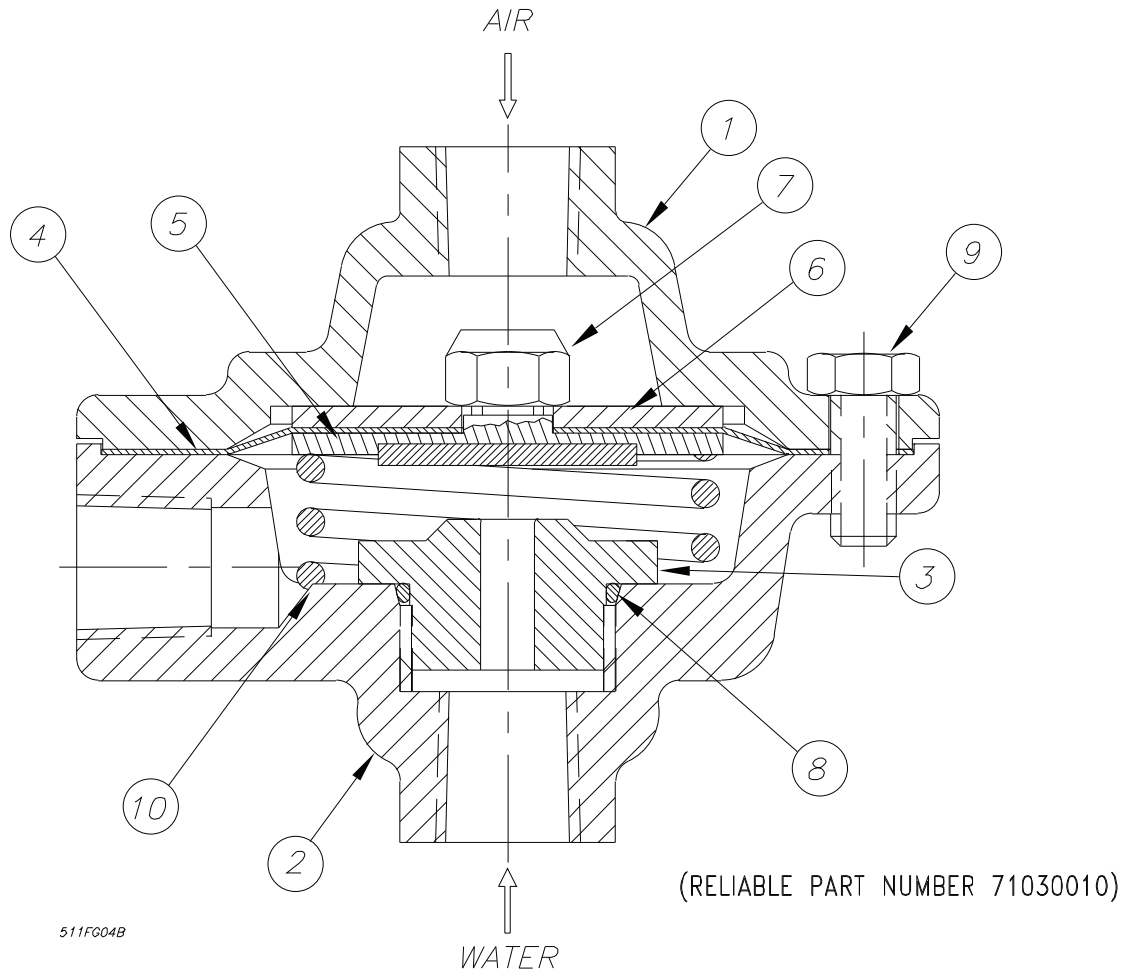

Fig. 7

### Model LP Dry Pilot Line Actuator Parts list P/N 71030010

Item No.	Part No.	Description	Qty. Required
1	94106936	Lower Housing	1
2	94106935	Upper Housing	1
3	96006905	Seat	1
4	92206311	Diaphragm	1
5	95106911	Facing Plate Assembly	1
6	96906311	Diaphragm Washer	1
7	94906406	Facing Plate Nut	1
8	95406901	Seat O-Ring	1
9	95606305	Bolt	6
10	96406902	Compression Spring	1

### Maintenance – Model LP Dry Valve Actuator

Refer to Figs. 6 and 7

If water constantly flows through the Model LP Dry Valve Actuator and into the drain, there is a leak in the seal of the Actuator's seat.

1. Close the main valve controlling water supply (Fig. 6) to the Dry Pipe Valve and close off the air/nitrogen supply to the sprinkler system. Close valve A (Fig. 6).
2. Drop pressure in the system by opening the ¼" globe valve, valve E (Fig. 6.), and remove the Actuator from the system.
3. Remove all six bolts (#9, Fig. 7) holding the Actuator together. Clean or replace the facing plate assembly (#5, Fig. 7) and seat (#3, Fig. 7).
4. Reassemble the Actuator, using a torque of 8 ft-lbs on the facing plate nut (#7, Fig. 7) and 12 ft-lbs on the six bolts (#9, Fig. 7). Use a cross-tightening pattern. Reinstall the Actuator. Set up the Model DDX-LP Dry Pipe Valve as per the section "Resetting Model DDX-LP Dry Pipe Valve System."

## Ordering Information

Specify:

- **Valve Model & Size** — 8" (200 mm) Model DDX Deluge Valve (P/N 6103080001)
- **Trim** — The trim set is available in individual parts, in time-saving segmentally assembled kit forms, or fully assembled to the Model DDX-LP Dry Pipe Valve (with or without a control valve).

Trim Configurations	Trim Part Numbers
Fully Assembled to DDX Valve w/ Control Valve	6505080220
Fully Assembled to DDX Valve w/o Control Valve	6505080221
Segmentally Assembled (DDX Valve Sold Separately)	6505041023
Individual Parts (DDX Valve Sold Separately)	6505041022

Note: For metric installations, a 2" NPT x R2. ISO 7/1 x Close Nipple (Reliable P/N 98543401) is sold separately as an adapter for the single drain outlet of the trims.

### Additional equipment

Component Part	Mfgr.	Description	Technical Bulletin
Water Supply Control Valve	Select	OS&Y, 8" (200 mm)	-
		Butterfly, 8" (200 mm)	-
Tamper Switch (Optional) for OS&Y Valve	B	Model OS&Y2	System Sensor A05-0196
Tamper Switch (Optional) for Butterfly Valve		Model P1BV2	System Sensor A05-0197
Deluge/Dry Valve	A	Model DDX-LP 8" (200 mm)	Reliable 514/515
Dry Pipe Valve System	A	Refer to Parts in this Bulletin	Reliable 335/336
Waterflow Alarm Pressure Switch	B	Model EPS10-2 (DPDT UL, FM)	System Sensor A05-0176
		Model EPSA10-2 (DPDT ULC)	
Low Air Alarm Pressure Switch	B	Model EPS40-2 (DPDT UL, FM)	System Sensor A05-0177
		Model EPSA40-2 (DPDT ULC)	
Mechanical Alarm (Optional)	A	Model C	Reliable 612/613
Manual Emergency Station	A	Model A Hydraulic (Pilot Line) Type	Reliable 506
Sprinklers	A	Closed Type	Reliable 110, 117, 131, 136, etc.
Air Compressor	C	Tank Mounted	Gast H-10-0801
Pressure Maintenance Device	A	Model A-2	Reliable 250/251
Accelerator Kit*	A	Model B1	Reliable 323
Nitrogen Regulating Device	A	Regulator with Optional Low Air Pressure Switch	Reliable 253

\*If the optional Model B1 Accelerator is used, a tank-mounted air compressor and an A-2 pressure maintenance device must be provided. Additionally the use of a tank-mounted air compressor helps to eliminate on/off compressor cycling that may occur as a result of small leakage in the air line between the pressure maintenance device and the 1/2" check valve, as well as due to ambient temperature changes in the system piping.

## System Equipment Manufacturers

(A) The Reliable Automatic Sprinkler Co., Inc.

(B) System Sensor

(C) Gast Manufacturing Corp.

# MODEL DDX-LP DRY PIPE VALVE SYSTEM COMPONENTS

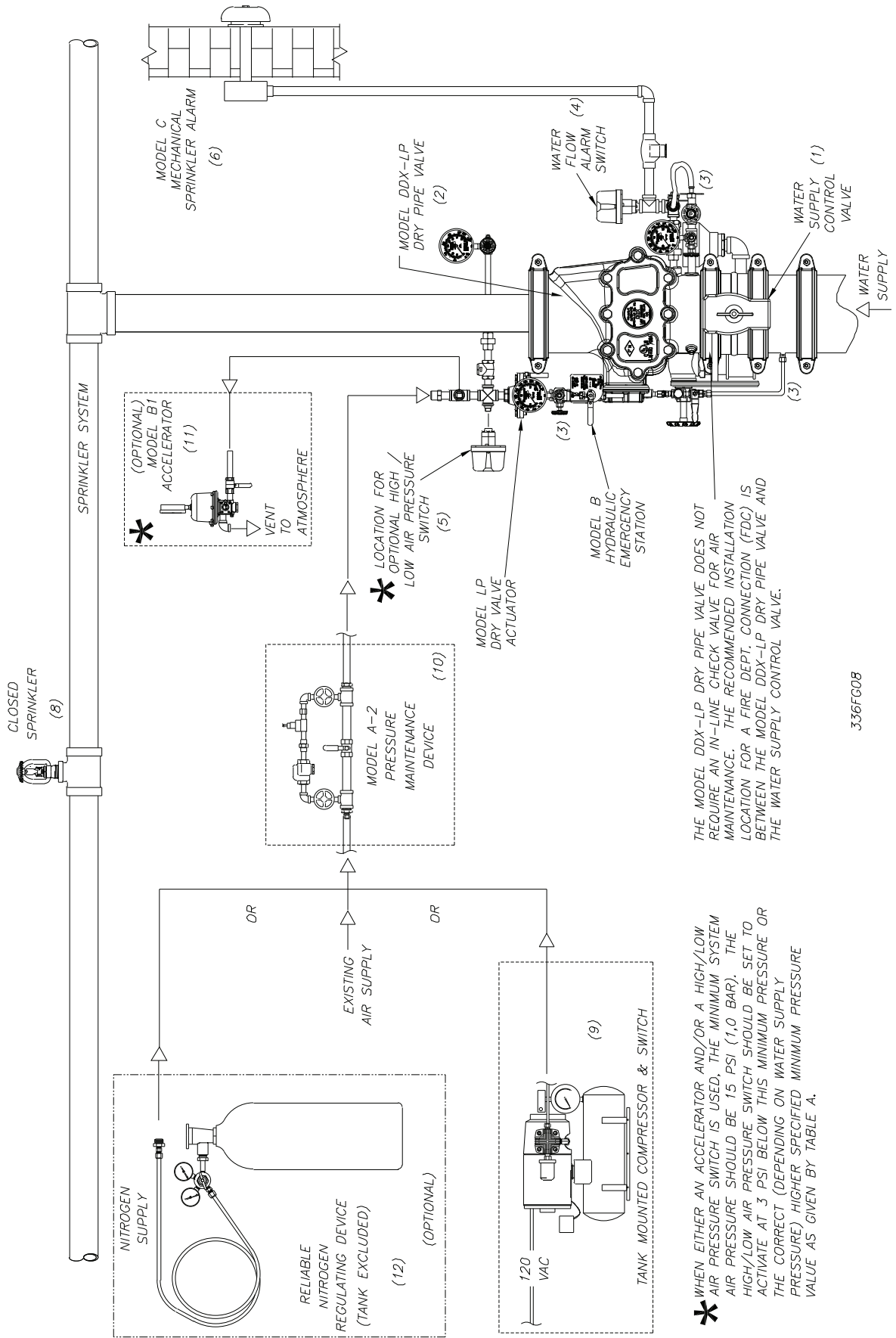

THE MODEL DDX-LP DRY PIPE VALVE DOES NOT REQUIRE AN IN-LINE CHECK VALVE FOR AIR MAINTENANCE. THE RECOMMENDED INSTALLATION LOCATION FOR A FIRE DEPT. CONNECTION (FDC) IS BETWEEN THE MODEL DDX-LP DRY PIPE VALVE AND THE WATER SUPPLY CONTROL VALVE.

\* WHEN EITHER AN ACCELERATOR AND/OR A HIGH/LOW AIR PRESSURE SWITCH IS USED, THE MINIMUM SYSTEM AIR PRESSURE SHOULD BE 15 PSI (1.0 BAR). THE HIGH/LOW AIR PRESSURE SWITCH SHOULD BE SET TO ACTIVATE AT 3 PSI BELOW THIS MINIMUM PRESSURE OR THE CORRECT (DEPENDS ON WATER SUPPLY PRESSURE) HIGHER SPECIFIED MINIMUM PRESSURE VALUE AS GIVEN BY TABLE A.

336FG08

Fig. 8

