

Reliable®

Model JL112 & J112 - Upright

ECLH - Extended Coverage Light Hazard

ECOH - Extended Coverage Ordinary Hazard

ECO - Extended Coverage Ordinary Hazard

- Quick Response

Model JL112 & J112 ECLH/ECOH Upright
(SIN R7326 – Link and RA7326 – Bulb)

- **Quick Response for Light Hazard**
(16' x 16' (4.9m x 4.9m), 18' x 18' (5.5m x 5.5m) and 20' x 20' (6.1m x 6.1m) spacing)
- **Quick Response for Ordinary Hazard**
(12' x 12' (3.7m x 3.7m) and 14' x 14' (4.3m x 4.3m) spacing)
- **Standard Response for Ordinary Hazard**
(16' x 16' (4.9m x 4.9m), 18' x 18' (5.5m x 5.5m) and 20' x 20' (6.1m x 6.1m) spacing)

Features

1. Extended Coverage Ordinary Hazard and Light Hazard protection to 400 ft² (37.2 m²) per sprinkler.
2. Nominal K = 11.2 (160).
3. Available in brass, chrome and polyester coated finishes.
4. For applications as per NFPA 13.

Approvals Organizations

1. Underwriters Laboratories, Inc. (UL)
2. Underwriters Laboratories of Canada (cULus)
3. NYC MEA 258-93-E

UL Listing Category

Sprinklers, Automatic and Open Extended Coverage Sprinklers-Ordinary Hazard Occupancy UL Guide Number – VNIIV.

The Reliable Model JL112 and J112 sprinkler are Extended Coverage Sprinklers for use in Ordinary Hazard 1 and 2 occupancies with a coverage area of up to 400 square feet (37.2m²) per sprinkler.

For all light hazard applications it is a Quick Response sprinkler. For ordinary hazard applications, it is a Standard Response sprinkler when the spacing is 16' x 16' (4.9m x 4.9m) and larger. When the spacing is 12' x 12' (3.7m x 3.7m) or 14' x 14' (4.3m x 4.3m), the sprinkler is Quick Response for ordinary hazard applications.

The use of ECLH/ECOH sprinklers can provide lower installation costs by requiring fewer sprinklers, less piping and reduced labor.

ECLH/ECOH sprinklers are to be installed according to the design criteria shown in this bulletin, NFPA 13, and all other local codes and ordinances. Flows and pressures as shown on pages 2 and 3 of this bulletin, must be used for the appropriate spacing and for the designated hazard classifications.

This ECLH/ECOH sprinkler is available in various finishes, which includes a white polyester corrosion resistant finish.

SIN RA7326 is Corrosion Resistant with White Polyester Coating.



**Model JL112 Upright
(R7326) - Link**



**Model J112 Upright
(RA7326) - Bulb**

Design Criteria

Reliable Model JL112 & J112 ECLH/ECOH sprinklers shall only be used in systems designed and installed in accordance with NFPA 13 and all other local codes and ordinances. The following design criteria also apply:

- Minimum sprinkler spacing is 8 ft (2.44m).
- Sprinklers have a minimum flow requirement for each spacing as shown in the Flow Requirements Table on the reverse side.
- Sprinklers are only to be used in systems hydraulically designed per NFPA 13.
- Deflector to commodity clearance shall be a minimum of 18 in (457mm).
- ECOH sprinklers shall be installed in unobstructed constructions as defined in NFPA 13. For open web truss construction web thickness is not to exceed 1 inch (25.4mm).
- ECOH sprinklers which are installed above the bottom of a horizontal obstruction, shall have their deflectors located as shown in the Obstruction Table on page 3.
- Sprinklers can be installed under a sloping ceiling not exceeding 2 inches (50.8mm) of rise in 12 inches (305mm).
- Maximum working pressure is 175 psi (12.07bar) at the sprinkler.

Sprinkler Model Specifications

Sprinkler Model	Type	Temperature Rating		Max. Ceiling Temp.		Maximum Sprinkler Spacing ft (m)	Maximum Coverage Area ft ² (m ²)	THD Size	Approvals
		°F	°C	°F	°C				
JL112 ECLH/ECOH- R7326	Link/Upright	165	74	100	38	20 (6.1)	400 (37.2)	¾" NPT (19mm)	1,2
JL112 ECLH/ECOH- R7326	Link/Upright	212	100	150	66				
J112 ECLH/ECOH- RA7326	Bulb/Upright	155	68	100	38	20 (6.1)	400 (37.2)		
J112 ECLH/ECOH- RA7326	Bulb/Upright	200	93	150	66				

Flow Requirements - Light Hazard - Quick Response

Spacing ft (m)	Coverage Area ft ² (m ²)	Flow gpm (lpm)	Pressure psi (bar)	"K" Factor	
				US	Metric
16 x 16 (4.9 x 4.9)	256 (23.8)	30 (113.6)	7.2 (0.5)	11.2	160.0
18 x 18 (5.5 x 5.5)	324 (30.1)	33 (124.9)	8.7 (0.6)		
20 x 20 (6.1 x 6.1)	400 (37.2)	40 (151.4)	12.8 (0.9)		

Flow Requirements - Ordinary Hazard - Standard Response

Spacing ft (m)	Coverage Area ft ² (m ²)	Ordinary Hazard 1		Ordinary Hazard 2		"K" Factor	
		0.15 gpm/ft ² (6.1 L/min/m ²) Density		0.20 gpm/ft ² (8.1 L/min/m ²) Density			
		Flow gpm (Lpm)	Pressure psi (bar)	Flow gpm (lpm)	Pressure psi (bar)	US	Metric
16 x 16 (4.9 x 4.9)	256 (23.8)	39 (147.6)	12.1 (0.8)	51 (193.0)	20.7 (1.4)	11.2	160.0
18 x 18 (5.5 x 5.5)	324 (30.1)	49 (185.5)	19.1 (1.3)	65 (246.0)	33.7 (2.3)		
20 x 20 (6.1 x 6.1)	400 (37.2)	60 (227.1)	28.7 (2.0)	80 (302.8)	51.0 (3.5)		

Flow Requirements - Ordinary Hazard - Quick Response

Spacing ft (m)	Coverage Area ft ² (m ²)	Ordinary Hazard 1		Ordinary Hazard 2		"K" Factor	
		0.15 gpm/ft ² (6.1 L/min/m ²) Density		0.20 gpm/ft ² (8.1 L/min/m ²) Density			
		Flow gpm (Lpm)	Pressure psi (bar)	Flow gpm (Lpm)	Pressure psi (bar)	US	Metric
14 x 14 (4.3 x 4.3)	196 (18.2)	30 (113.6)	7.2 (0.5)	39 (147.6)	12.1 (0.8)	11.2	160.0
12 x 12 (3.7 x 3.7)	144 (13.4)						

J1 Wrench



Model J1 Sprinkler Wrench

Use Model J1 Wrench for JL112 & J112
ECLH/ECOH Upright Sprinkler Removal and
Installation

Finishes

Sprinkler Finishes
Sprinkler
Bronze Chrome White Polyester Coated

Ordering Information

1. Sprinkler Model
2. Temperature Rating
3. Finish

Corrosion Resistant		
J112 ECLH/ECOH	Bulb	
	°F	°C
	155	68
200	93	

Minimum Flow Requirements For Earlier Editions of NFPA 13 - FOR REFERENCE ONLY

Spacing ft (m)	Coverage Area ft ² (m ²)	NFPA13 - 1991 Requirements				NFPA13 - 1989 Requirements						"K" Factor	
		Ordinary Hazard 1		Ordinary Hazard 2		Ordinary Hazard 1		Ordinary Hazard 2		Ordinary Hazard 3		US	Metric
		0.15 gpm/ft ² (6.1 L/min/m ²) Density		0.20 gpm/ft ² (8.1 L/min/m ²) Density		0.16 gpm/ft ² (6.5 L/min/m ²) Density		0.19 gpm/ft ² (7.7 L/min/m ²) Density		0.21 gpm/ft ² (8.6 L/min/m ²) Density			
		Flow gpm (Lpm)	Pressure psi (bar)	Flow gpm (Lpm)	Pressure psi (bar)	Flow gpm (Lpm)	Pressure psi (bar)	Flow gpm (Lpm)	Pressure psi (bar)	Flow gpm (Lpm)	Pressure psi (bar)	Flow gpm (Lpm)	Pressure psi (bar)
14 x 14 (4.3 x 4.3) and less	196 (18.2)	30.2 (114.3)	7.0 (0.48)	39.2 (148.3)	11.9 (0.82)	31.4 (118.8)	7.6 (0.52)	37.3 (141.2)	10.7 (0.74)	41.2 (155.9)	13.0 (0.90)	11.4	164.4
16 x 16 (4.9 x 4.9)	256 (23.8)	38.4 (145.3)	11.4 (0.79)	51.2 (193.8)	20.2 (1.39)	41.0 (155.2)	12.9 (0.89)	48.7 (184.3)	18.2 (1.26)	53.8 (203.6)	22.3 (1.54)		
18 x 18 (5.5 x 5.5)	324 (30.1)	48.6 (184.0)	18.2 (1.24)	64.8 (258.9)	32.3 (2.23)	51.9 (196.4)	20.7 (1.43)	61.6 (233.2)	29.2 (2.01)	68.0 (257.4)	35.7 (2.46)		
20 x 20 (6.1 x 6.1)	400 (37.2)	60.0 (227.1)	27.7 (1.91)	80.0 (302.8)	49.3 (3.40)	64.0 (242.2)	31.5 (2.17)	76.0 (287.7)	44.5 (3.07)	84.0 (317.9)	54.3 (3.75)		

Installation Requirements for Under Concrete Tees - cULus

- The stems of the concrete tee construction must be spaced at less than 7.5 feet (2.3m) on center but more than 3 feet (0.9m) on center. The depth of the concrete tees must not exceed 30 inches (762mm). The maximum permitted concrete tee length is 32 feet (9.8m); however, where the concrete tee length exceeds 32 feet (9.8m), non-combustible baffles, equal in height to the depth of the tees, can be installed so that the longitudinal space between the tees does not exceed 32 feet (9.8m) in length.
- The sprinkler deflectors are to be located in a horizontal plane at or above 1 inch (25.4mm) below the bottom of the concrete tee stems.
- When the sprinkler deflectors are located higher than a horizontal plane 1 inch (25.4mm) beneath the bottom of the concrete tee stems, the obstruction to sprinkler discharge criteria requirements of NFPA 13 for extended coverage upright sprinkler applies.

Location of Deflector to Horizontal Obstruction

Distance from Sprinkler to Side of Obstruction	Maximum Allowable Distance Deflector Above Bottom of Obstruction
Less than 1'.....	0"
(Less than 0.305m.....)	0mm)
1' to less than 1' - 6".....	0"
(0.305m to less than 0.305m - 152.4mm.....)	0mm)
1' - 6" to less than 2'.....	1"
(0.305m - 152.4mm to less than 0.61m.....)	25.4mm)
2' to less than 2' - 6".....	1"
(0.61m to less than 0.61m - 152.4mm.....)	25.4mm)
2' - 6" to less than 3'.....	1"
(0.61m - 152.4mm to less than 0.915m.....)	25.4mm)
3' to less than 3' - 6".....	3"
(0.915m to less than 0.915m - 152.4mm.....)	76.2mm)
3' - 6" to less than 4'.....	4"
(0.915m - 152.4mm to less than 1.22m.....)	101.6mm)
4' to less than 4' - 6".....	5"
(1.22m to less than 1.22m - 152.4mm.....)	127mm)
4' - 6" to less than 5'.....	7"
(1.22m - 152.4mm to less than 1.525m.....)	177.8mm)
5' to less than 5' - 6".....	7"
(1.525m to less than 1.525m - 152.4mm.....)	177.8mm)
5' - 6" to less than 6'.....	7"
(1.525m - 152.4mm to less than 1.83m.....)	177.8mm)
6' to less than 6' - 6".....	9"
(1.83m to less than 1.83m - 152.4mm.....)	228.6mm)
6' - 6" to less than 7'.....	11"
(1.83m - 152.4mm to less than 2.135m.....)	279.4mm)
7' and greater.....	14"
(2.135m and greater.....)	355.6mm)

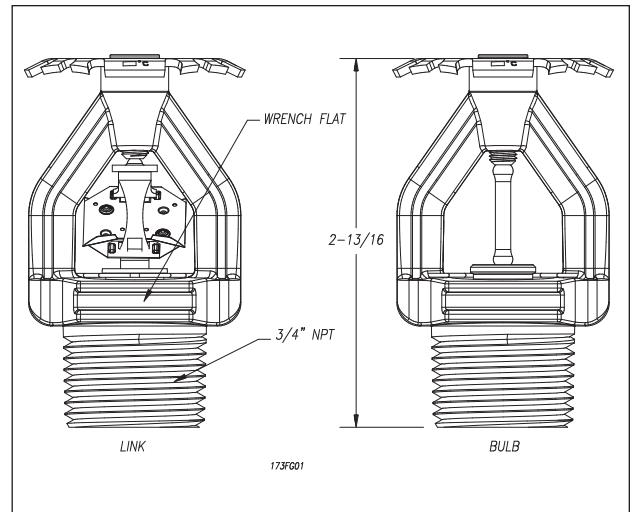

Fig. 1

Solder Link			Bulb			
Classification	°F	°C	Classification	°F	°C	Bulb Color
Ordinary	165	74	Ordinary	155	68	Red
*Intermediate	212	100	Intermediate	200	93	Green

*Ordinary Hazard only

The equipment presented in this bulletin is to be installed in accordance with the latest published Standards of the National Fire Protection Association, Factory Mutual Research Corporation, or other similar organizations and also with the provisions of governmental codes or ordinances whenever applicable. Products manufactured and distributed by Reliable have been protecting life and property for over 90 years, and are installed and serviced by the most highly qualified and reputable sprinkler contractors located throughout the United States, Canada and foreign countries.

Manufactured by



The Reliable Automatic Sprinkler Co., Inc.
 (800) 431-1588 Sales Offices
 (800) 848-6051 Sales Fax
 (914) 829-2042 Corporate Offices
 www.reliablesprinkler.com Internet Address



Revision lines indicate updated or new data.

EG. Printed in U.S.A. 10/11 P/N 9999970311