

# Reliable®

## Model GFR VELO—ECO<sup>H</sup> Extended Coverage Ordinary Hazard Pendent and Recessed Pendent Sprinklers

### Model GFR VELO-ECO<sup>H</sup> Pendent & Recessed Pendent (SIN R6043)

#### Features

1. Provides Extended Coverage Ordinary Hazard protection to 400 ft<sup>2</sup> (37.2m<sup>2</sup>) per sprinkler.
2. Very extra large orifice of nominal K =14 (200) permits low pressures.
3. Available in pendent or recessed pendent styles.
4. Recessed pendent version provides 3/4" (19mm) adjustment to flush pendent position.
5. 212°F (100°C) or 165°F (74°C) temperature rating.
6. Available in brass, chrome, black plated and polyester coated finishes.
7. Can be used for all editions of NFPA 13.

#### Approval Organizations

1. Underwriters Laboratories, Inc. (UL)
2. Underwriters Laboratories of Canada (ULC)
3. NYC MEA 258-93-E

#### UL Listing Category

Sprinklers, Automatic and Open  
Extended Coverage Sprinklers—  
Ordinary Hazard Occupancy

#### UL Guide Number

VNIV

#### Description

The Reliable VELO—ECO<sup>H</sup> Extended Coverage Sprinkler has a very extra large orifice with a nominal K=14 (200). It can provide Ordinary Hazard protection to 400 ft<sup>2</sup> (37.2m<sup>2</sup>) at lower pressures than an XLO which has a nominal K=11.2 (160). VELO sprinklers are standard response and are available in a pendent or an attractive recessed pendent type which provides up to 3/4" (19mm) of escutcheon adjustment. Various finishes are available.

Reliable VELO—ECO<sup>H</sup> sprinklers provide protection in Ordinary Hazard Group 1 and 2 Occupancies to 400 ft<sup>2</sup> (37.2 m<sup>2</sup>) per sprinkler when the system is designed to NFPA 13 hydraulic density requirements.



Model GFR VELO—ECO<sup>H</sup>  
Pendent

ECO<sup>H</sup> pendent and recessed pendent sprinklers are to be installed according to the design criteria shown in this bulletin. The use of ECO<sup>H</sup> sprinklers can provide lower system installation costs by requiring fewer sprinklers, less piping and reduced labor.

Model GFR VELO sprinklers use a levered fusible alloy solder link.

#### Design Criteria

Reliable Model GFR VELO—ECO<sup>H</sup> sprinklers shall only be used in systems designed and installed in accordance with NFPA 13 and all other local codes and ordinances. The following design criteria also apply:

- Minimum sprinkler spacing is 13 ft. (4.0m).
- Sprinklers have a minimum flow requirement for each spacing as shown in the "Flow Requirements" Table on the reverse side.
- ECO<sup>H</sup> sprinklers are only to be used in systems hydraulically designed per NFPA 13 and for a minimum area of 1500 ft<sup>2</sup> (139m<sup>2</sup>) or 5 sprinklers, whichever is greater.
- Deflector to commodity clearance shall be a minimum of 18" (457mm).
- ECO<sup>H</sup> sprinklers shall be installed in unobstructed constructions as defined in NFPA 13. For open web truss construction web thickness is not to exceed 1" (25mm).
- ECO<sup>H</sup> sprinklers, which are installed above the bottom of a horizontal obstruction, shall have their deflectors located as shown in the "Obstruction Table" on the reverse side.
- Sprinklers can be installed under a sloping ceiling not exceeding 2 inches (50mm) of rise in 1 ft. (0.3m).
- Maximum working pressure is 175 psi (12 bar) at the sprinkler.

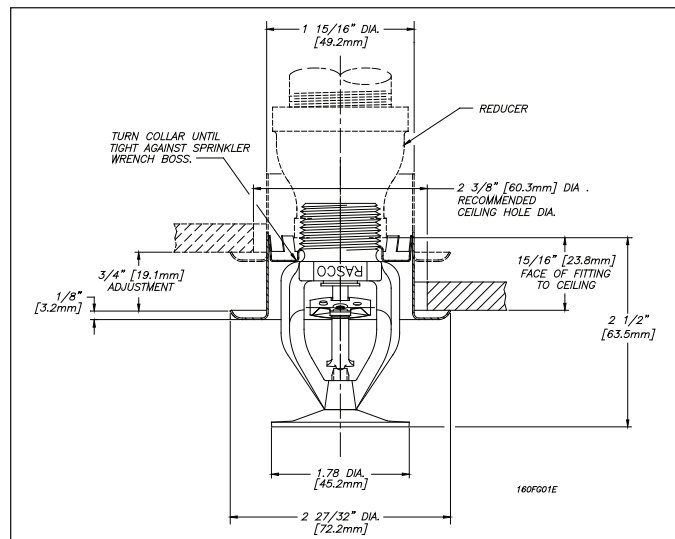

## Sprinkler Model Specifications

Sprinkler Model	Type	Temperature Rating		Maximum Ceiling Temp.		Maximum Sprinkler Spacing	Maximum Coverage Area	Thread Size	Approvals	Sprinkler Identification Number (SIN)
		°F	°C	°F	°C					
GFR VELO-ECOH <sup>(1)</sup>	PEND & REC <sup>(2)</sup>	165	74	100	38	20' (6.0m)	400 ft <sup>2</sup> (37.2m <sup>2</sup> )	¾" NPT (R¾)	1,2,3	R6043
GFR VELO-ECOH <sup>(1)</sup>	PEND & REC <sup>(2)</sup>	212	100	150	66					

<sup>(1)</sup> Listed as standard response.

<sup>(2)</sup> Use only Model F1 recessed escutcheon, ¾" NPT (R¾) size.

## Minimum Flow Requirements

Spacing		Coverage Area		NFPA 13-1991 & Later				NFPA 13-1989 and Earlier				Nominal K Factor			
				Ordinary Hazard 1		Ordinary Hazard 2		Ordinary Hazard 1		Ordinary Hazard 2				Ordinary Hazard 3	
				0.15 gpm/ft <sup>2</sup> (6.1 L/min/m <sup>2</sup> ) Density		0.20 gpm/ft <sup>2</sup> (8.1 L/min/m <sup>2</sup> ) Density		0.16 gpm/ft <sup>2</sup> (6.5 L/min/m <sup>2</sup> ) Density		0.19 gpm/ft <sup>2</sup> (7.7 L/min/m <sup>2</sup> ) Density				0.21 gpm/ft <sup>2</sup> (8.5 L/min/m <sup>2</sup> ) Density	
		Flow gpm (L/min)	Pressure psi (bar)	Flow gpm (L/min)	Pressure psi (bar)	Flow gpm (L/min)	Pressure psi (bar)	Flow gpm (L/min)	Pressure psi (bar)	Flow gpm (L/min)	Pressure psi (bar)	US	Metric		
18' x 18' (5.5m x 5.5m) and less		324 ft <sup>2</sup> (30.1m <sup>2</sup> )	48.6 (184)	12.1 (0,8)	64.8 (245.3)	21.4 (1,5)	51.8 (196.1)	13.7 (1,0)	61.6 (233.2)	19.4 (1,4)	68.0 (257.4)			23.6 (1,7)	14
20' x 20' (6.0m x 6.0m)		400 ft <sup>2</sup> (37.2m <sup>2</sup> )	60.0 (227)	18.4 (1,3)	80.0 (302)	32.7 (2,3)	64.0 (242)	20.9 (1,5)	76.0 (287)	29.5 (2,1)	84.0 (318)	36.0 (2,5)			

## Location of Deflector to Obstruction

Distance from Sprinkler to Side of Obstruction	Maximum Allowable Distance Deflector Above Bottom of Obstruction (in.)
Less than 1'-0"	0
1' to less than 1'-6"	0
1'-6" to less than 2'-0"	1
2'-0" to less than 2'-6"	1
2'-6" to less than 3'-0"	1
3'-0" to less than 3'-6"	3
3'-6" to less than 4'-0"	3
4'-0" to less than 4'-6"	5
4'-6" to less than 5'-0"	7
5'-0" to less than 5'-6"	7
5'-6" to less than 6'-0"	7
6'-0" to less than 6'-6"	9
6'-6" to less than 7'-0"	11
7'-0" and greater	14

For SI units, 1 in. = 25.4 mm; 1 ft. = .3048 m

## Ordering Information

1. Sprinkler Model
2. Temperature Rating
3. Sprinkler Finish
4. Escutcheon and finish (where applicable)

## Finishes<sup>(1)</sup>

Standard Finishes	
Sprinkler	Escutcheon
Bronze	Brass
Chrome	Chrome
White Polyester Coated <sup>(2)</sup>	White Painted

<sup>(1)</sup> Other colors and finishes are available upon request. Consult Factory for details.

<sup>(2)</sup> Frame and deflector are polyester coated; operating parts are chrome plated.

### Model H Sprinkler Wrench

Use Model H Wrench for VELO-ECOH Pendent Sprinkler Removal and Installation



### Model XLO Sprinkler Wrench

Use Model XLO Wrench for VELO-ECOH Recessed Sprinkler Removal and Installation



The equipment presented in this bulletin is to be installed in accordance with the latest published Standards of the National Fire Protection Association, Factory Mutual Research Corporation, or other similar organizations and also with the provisions of governmental codes or ordinances whenever applicable. Products manufactured and distributed by Reliable have been protecting life and property for over 90 years, and are installed and serviced by the most highly qualified and reputable sprinkler contractors located throughout the United States, Canada and foreign countries.

Manufactured by

# Reliable®

### The Reliable Automatic Sprinkler Co., Inc.

(800) 431-1588

(800) 848-6051

(914) 829-2042

www.reliablesprinkler.com

Sales Offices

Sales Fax

Corporate Offices

Internet Address



Recycled Paper

Revision lines indicate updated or new data.

EG. Printed in U.S.A 03/11

P/N 9999970033