

Reliable®

Model F1FR – 300 Quick Response Extended Coverage Sprinklers 300 psi (20,7 bar) Rated

Model F1FR – 300 QREC 300 psi (20,7 bar) Rated Sprinkler Types

- Extended Coverage Pendant (QREC)
- Extended Coverage Horizontal Sidewall (QREC-9)
- Extended Coverage Recessed Pendant (QREC)
- Extended Coverage Recessed Horizontal Sidewall (QREC-9)

Product Description

Reliable Models F1FR-300 QREC and F1FR-300 QREC-9 pendant and horizontal sidewall sprinklers are high pressure rated automatic sprinklers which can handle a maximum service pressure of 300 psi (20,7 bar).

These Models are quick response sprinklers which utilize a 3.0mm frangible glass bulb. These sprinklers have demonstrated response times in laboratory tests which are five times faster than standard response sprinklers. This quick response enables Model F1FR-300 QREC and QREC-9 sprinklers to apply water to a fire much faster than standard sprinklers of the same temperature rating.

The glass bulb contains an accurately controlled amount of special fluid hermetically sealed inside a precisely manufactured glass capsule. This glass bulb is specially constructed to provide fast thermal response. Other sprinkler parts are made of brass, copper or beryllium nickel.

At normal temperatures, the glass bulb contains fluid in both the liquid and vapor phases. The vapor phase can be seen as a small bubble. As heat is applied, the liquid expands, forcing the bubble smaller and smaller as the liquid pressure increases. Continued heating forces the liquid to push out against the bulb, causing the glass to shatter, operating the waterway and allowing the deflector to distribute the discharging water.

The temperature rating of the sprinkler is identified by the color of the glass bulb.



QREC Pendant

Recessed
QREC PendantQREC-9 Horizontal
SidewallRecessed QREC-9
Horizontal Sidewall

Application

The most common applications for Model F1FR-300 QREC and QREC-9 Sprinklers will be in fire protection systems for high rise buildings where a quick response rating is required and the pressure entering the sprinkler system is in excess of 175 psi (12 bar). The use of these sprinklers will provide the opportunity to reduce or eliminate the need for pressure reducing valves.

Model F1FR-300 Quick Response Extended Coverage Pendent Sprinkler

Deflector: QREC

Installation Wrench: Model D Sprinkler Wrench

Approval Type: Quick Response Extended Coverage – Light Hazard Occupancy

Installation Data:

Nominal Orifice Size	Thread Size	“K” Factor		Sprinkler Length	Approval Organizations	Temperature Rating	Sprinkler Identification Number (SIN)
		US	Metric				
½” (15mm)	½” NPT (R½)	5.62	81.0	2.2” (56.1mm)	1, 2	135°F (57°C) 155°F (68°C)	R5945
⅞” (20mm)	¾” NPT (R¾)	8.0	115.3	2.4” (61mm)	1, 2	135°F (57°C) 155°F (68°C)	R5942



QREC Pendent

Model F1FR-300 Quick Response Extended Coverage Recessed Pendent Sprinkler

Deflector: QREC

Installation Wrench: Model GFR1 Sprinkler Wrench

Approval Type: Quick Response Extended Coverage – Light Hazard Occupancy

Installation Data:

Nominal Orifice Size	Thread Size	“K” Factor		Sprinkler Length	Approval ⁽²⁾ Organizations	Temperature Rating	Sprinkler Identification Number (SIN)
		US	Metric				
½” (15mm)	½” NPT (R½)	5.62	81.0	2.2” (56mm)	1, 2	135°F (57°C) 155°F (68°C)	R5945
⅞” (20mm)	¾” NPT (R¾)	8.0	115.3	2.4” (61mm)	1, 2	135°F (57°C) 155°F (68°C)	R5942

Coverage Area							
Flow Rate		Pressure				Max. Coverage Area Width x Length	
gpm	L/min	K = 8.0 (115.3)		K = 5.62 (81.0)		ft. x ft.	m x m
		psi	bar	psi	bar		
26	98.4	10.6	0.7	21.6	1.5	16 x 16	4.9 x 4.9
33	124.9	17.0	1.2	34.7	2.4	18 x 18	5.5 x 5.5
40	151.5	25.0	1.7	51.0	3.5	20 x 20 ⁽¹⁾	6.0 x 6.0 ⁽¹⁾

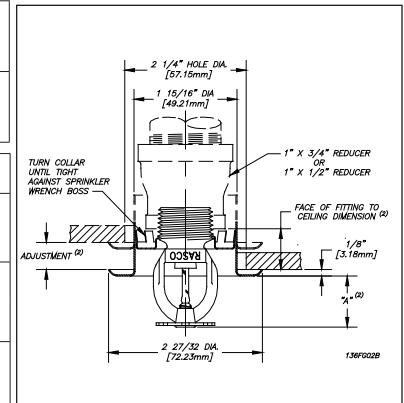

⁽¹⁾135°F only.

⁽²⁾Refer to escutcheon data table for approvals and dimensions.

Model F1FR-300 Quick Response Extended Coverage Horizontal Sidewall Sprinkler

Deflector: QREC-9

Installation Wrench: Model D Sprinkler Wrench

Approval Type: Quick Response Extended Coverage – Light Hazard Occupancy

Installation Data:

Nominal Orifice Size	Thread Size	“K” Factor		Sprinkler Length	Approval Organizations	Temperature Rating	Sprinkler Identification Number (SIN)
		US	Metric				
⅞” (20mm)	¾” NPT (R¾)	8.0	115.3	2.95” (75mm)	1, 2	135°F (57°C) 155°F (68°C)	R5962

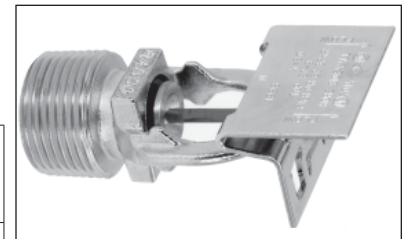

QREC-9 Horizontal Sidewall

Model F1FR-300 Quick Response Extended Coverage Recessed Horizontal Sidewall Sprinkler

Deflector: QREC-9

Installation Wrench: Model GFR1 Sprinkler Wrench

Approval Type: Quick Response Extended Coverage – Light Hazard Occupancy

Installation Data:

Nominal Orifice Size	Thread Size	"K" Factor		Sprinkler Length	Approval ⁽²⁾ Organizations	Sprinkler Identification Number (SIN)
		US	Metric			
17/32" (20mm)	3/4" NPT (R3/4)	8.0	115.3	2.95" (75mm)	1, 2	R5962

⁽²⁾Refer to Escutcheon Data Table for approvals and dimensions.

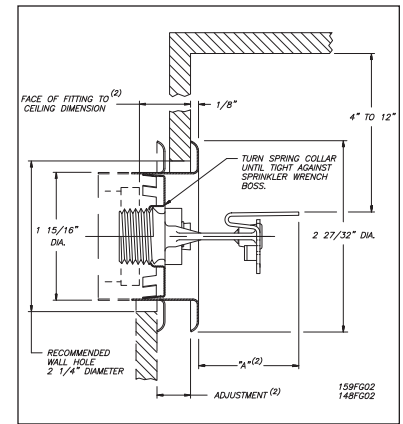

Installation Data:

COVERAGE AREA				
Flow Rate gpm (L/min)	Pressure psi (bar)	Maximum Coverage Area Width x Length ft. x ft. (m x m)	Temperature Rating ⁽¹⁾	Deflector to Ceiling Dimension Min. - Max. Inches (mm)
UL	UL			
26 (98.4)	10.6 (0,7)	16 x 16 (4.9 x 4.9)	135°F (57°C)	6 - 12 (153 - 305)
29 (109.8)	13.1 (0,9)	16 x 16 (4.9 x 4.9)	155°F (68°C)	4 - 12 (102 - 305)
29 (109.8)	13.1 (0,9)	16 x 18 (4.9 x 5.5)	175°F (78°C)	4 - 12 (102 - 305)
32 (121.1)	16.0 (1,1)	16 x 20 (4.9 x 6.0)		4 - 12 (102 - 305)
36 (136.3)	20.2 (1,4)	16 x 22 (4.9 x 6.7)		4 - 12 (102 - 305)
39 (147.6)	23.8 (1,6)	16 x 24 (4.9 x 7.3)		4 - 12 (102 - 305)
33 (124.9)	17.0 (1,2)	18 x 18 (5.5 x 5.5)	135°F (57°C)	4 - 12 (102 - 305)
39 (147.6)	23.8 (1,6)	14 x 26 (4.3 x 7.9)	135°F (57°C)	4 - 6 (102 - 153)
40 (151.4)	25.0 (1,7)	18 x 22 (5.5 x 6.7)	135°F (57°C)	4 - 12 (102 - 305)
46 (174.1)	33.1 (2,25)	14 x 26 (4.3 x 7.9)	135°F (57°C)	6 - 12 (153 - 305)
33 (124.9)	17.0 (1,2)	18 x 18 (5.5 x 5.5)	155°F (68°C)	4 - 12 (102 - 305)
40 (151.4)	25.0 (1,7)	18 x 22 (5.5 x 6.7)	155°F (68°C)	4 - 12 (102 - 305)
46 (174.1)	33.1 (2,25)	14 x 26 (4.3 x 7.9)	155°F (68°C)	6 - 12 (153 - 305)

Installation

Quick response sprinklers are intended for installation as specified in NFPA 13. Quick response sprinklers and standard response sprinklers should not be intermixed.

The Model F1FR-300 QREC and QREC-9 Recessed Sprinklers are to be installed as illustrated. The Model F1 or F2 escutcheons illustrated are the only recessed escutcheons to be used with these sprinklers. The use of any other recessed escutcheon will void all approvals and negate all warranties.

When installing Model F1FR-300 QREC Pendent and QREC-9 Horizontal Sidewall Sprinklers, use the Model D Sprinkler Wrench. When installing F1FR-300 QREC Recessed Pendent and F1FR-300 QREC-9 Recessed Horizontal Sidewall Sprinkler, use the Model GFR1 Sprinkler Wrench. Any other type of wrench may damage these sprinklers.

Glass bulb sprinklers have orange bulb protectors to minimize bulb damage during shipping, handling and installation. REMOVE THIS PROTECTION AT THE TIME THE SPRINKLER SYSTEM IS PLACED IN SERVICE FOR FIRE PROTECTION. Removal of the protectors before this time

may leave the bulb vulnerable to damage. RASCO wrenches are designed to install sprinklers when covers are in place. REMOVE PROTECTORS BY UNDOING THE CLASP BY HAND. DO NOT USE TOOLS TO REMOVE THE PROTECTORS.

Maintenance

Model F1FR-300 Extended Coverage Sprinklers should be inspected quarterly and the sprinkler system maintained in accordance with NFPA 25. Do not clean sprinklers with soap and water, ammonia or any other cleaning fluids. Remove dust by using a soft brush or gentle vacuuming. Remove any sprinkler that has been painted (other than factory applied) or damaged in any way. A stock of spare sprinklers should be maintained to allow quick replacement of damaged or operated sprinklers. Prior to installation, sprinklers should be maintained in the original cartons and packaging until used to minimize the potential for damage to sprinklers that would cause improper operation or non-operation.

Approval Organizations

1. Underwriters Laboratories Inc.
2. UL Certified for Canada
3. NYC MEA 258-93-E

ULI Listing Category

Sprinklers, Automatic & Open
Quick Response Sprinklers

ULI Guide Number

VNIV

Sprinkler Types

- Pendent (QREC)
- Horizontal Sidewall (QREC-9)
- Recessed Pendent (QREC)
- Recessed Horizontal Sidewall (QREC-9)

Temperature Ratings

Classification	Sprinkler Temperature		Maximum Ambient Temp.		Bulb Color
	°F	°C	°F	°C	
Ordinary	135	57	100	38	Orange
Ordinary	155	68	100	38	Red
Intermediate	175	79	150	66	Yellow

Escutcheon Data

Sprinkler Type	Escutcheon Model	Approvals	Adjustment	"A" Dimension	Face of Fitting to Ceiling or Wall Dimensions
F1FR-300 QREC Pend	F1	1, 2	¾" (19mm)	¾" (19mm)	³ / ₁₆ " to ¹⁵ / ₁₆ " (5mm to 24mm)
F1FR-300 QREC-9 HSW	F2	1, 2	¾" (19mm)	1" (35mm)	³ / ₁₆ " to ¹¹ / ₁₆ " (5mm to 18mm)

Ordering Information

Specify:

1. Sprinkler Model
2. Sprinkler Type
3. Orifice Size
4. Deflector Type
5. Temperature Rating
6. Sprinkler Finish
7. Escutcheon Type
8. Escutcheon Finish (where applicable)

Note: When Recessed sprinklers are ordered, the sprinklers and escutcheons are packaged separately.

Finishes⁽¹⁾

Standard Finishes	
Sprinkler	Escutcheon
Bronze Chrome White Polyester Coated	Brass Chrome White Painted
Special Application Finishes	
Sprinkler	Escutcheon
Bright Brass Black Plated Black Paint Off White Satin Chrome	Bright Brass Black Plated Black Paint Off White Satin Chrome

⁽¹⁾ Other colors and finishes are available on special order.
Consult factory for details

The equipment presented in this bulletin is to be installed in accordance with the latest published Standards of the National Fire Protection Association, Factory Mutual Research Corporation, or other similar organizations and also with the provisions of governmental codes or ordinances whenever applicable. Products manufactured and distributed by Reliable have been protecting life and property for over 80 years, and are installed and serviced by the most highly qualified and reputable sprinkler contractors located throughout the United States, Canada and foreign countries.

Manufactured by

Reliable[®]

The Reliable Automatic Sprinkler Co., Inc.

(800) 431-1588 Sales Offices
 (800) 848-6051 Sales Fax
 (914) 829-2042 Corporate Offices
 www.reliablesprinkler.com Internet Address



Revision lines indicate updated or new data.

EG. Printed in U.S.A 12/09 P/N 9999970164