

Reliable®

Model F1 – 300 300 psi (20,7 bar) Rated Standard Response Extended Coverage Sprinklers

Model F1-300

Sprinkler Types

- Extended Coverage Pendant
- Recessed Extended Coverage Pendant

For Model F1-300 EC ½" K 5.6 (80) Sprinkler Types refer to Bulletin 027 for technical specifications and approvals.

Approval Organizations

1. Underwriters Laboratories, Inc. (UL)
2. UL Certified for Canada (ULC)

UL Listing Category

Sprinklers, Automatic & Open (VNIV)

Product Description

Models F1-300 EC Pendant and F1-300 EC Recessed Pendant Sprinklers are high pressure rated automatic sprinklers which can handle a maximum service pressure of 300 psi (20,7 bar).

The Model F1-300 glass bulb sprinkler combines durability of a standard sprinkler with the attractive low profile of a decorative sprinkler. Whether installed on exposed piping or below an office ceiling, it is functional and attractive.

The Model F1 Recessed Escutcheon provides convenient adjustment for Model F1-300 EC Sprinklers. The two-piece construction makes field installation an easy and rapid task. This also allows ceiling panels to later be removed without shutting down the fire protection system, thus facilitating maintenance of above ceiling services.

The Models F1-300 EC Pendant and Recessed Pendant automatic sprinklers are standard response sprinklers which utilize a 5.0mm frangible glass bulb. The glass bulb contains an accurately controlled amount of special fluid hermetically sealed inside. The other sprinkler parts are made of brass, copper and beryllium nickel.

At normal temperatures, the glass bulb contains fluid in both the liquid and vapor phases. The vapor phase can be seen as a small bubble. As heat is applied, the liquid expands, forcing the bubble smaller and smaller as the liquid pressure increases. Continued heating forces the liquid to push out against the bulb, causing the glass to shatter, opening the waterway and allowing the deflector to distribute the discharging water.

The temperature rating of the sprinkler is identified by the color of the glass bulb capsule as well as frame color where applicable.



Pendant



Recessed Pendant

Application

The most common applications for Model F1-300 EC Pendant and Recessed EC Pendant Sprinklers will be in fire protection systems for high rise buildings or where the pressure entering the sprinkler system is in excess of 175 psi (12 bar). The use of these sprinklers will provide an opportunity to reduce or eliminate the need for pressure reducing valves.

Model F1-300 Extended Coverage Pendant Sprinkler

Deflector: EC

Installation Wrench: Model D Sprinkler Wrench

Approval Type: Extended Coverage – Light Hazard Occupancy



EC Pendant

Installation Data:

Nominal Orifice	Thread Size	K Factor		Sprinkler Length	Approval Organizations	Temperature	Sprinkler Identification Numbers (SIN)
		US	Metric				
$17/32"$ (20mm)	$3/4"$ NPT (R $3/4$)	8.0	115.3	2.4" (61mm)	1, 2	135°F (57°C) 155°F (68°C)	R5842

Model F1-300 Extended Coverage Recessed Pendant Sprinkler

Deflector: EC

Installation Wrench: Model GFR2 Sprinkler Wrench

Approval Type: Extended Coverage – Light Hazard Occupancy



Recessed Pendant

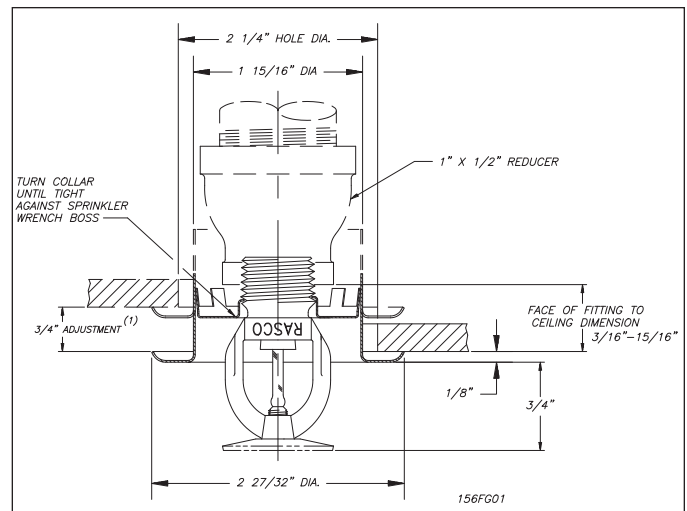

⁽¹⁾When sprinkler is installed directly into a tee, the escutcheon dimension's adjustment will be reduced.

Installation Data:

Nominal Orifice	Thread Size	K Factor		Sprinkler Length	Approval Organizations	Temperature	Sprinkler Identification Numbers (SIN)
		US	Metric				
$17/32"$ (20mm)	$3/4"$ NPT (R $3/4$)	8.0	115.3	2.4" (61mm)	1, 2	135°F (57°C) 155°F (68°C)	R5842

COVERAGE AREA

Flow Rate		Pressure		Max. Coverage Area Width x Length	
		K = 8.0 (115.3)			
gpm	L/min	psi	bar	ft. x ft.	m x m
26	98.4	10.6	0,7	16 x 16	4.9 x 4.9
33	125.0	17.0	1,2	18 x 18	5.5 x 5.5
40	151.4	25.0	1,7	20 x 20 ⁽¹⁾	6.0 x 6.0 ⁽¹⁾

⁽¹⁾ 135°F (57°C) Only

Installation

Model F1-300 EC sprinklers are standard response sprinklers intended for installation as specified in NFPA 13. They must be installed with the Model D Sprinkler Wrench specifically designed by Reliable for use with these sprinklers.

The Model F1-300 EC Recessed Sprinklers are to be installed with a maximum recess of 3/4" (19mm). The Model F1 escutcheon illustrated is the only recessed escutcheon to be used with Model F1-300 EC Pendent Sprinklers. The use of any other recessed escutcheon will void all approvals and negate all warranties. When installing Model F1-300 EC Recessed Pendent sprinklers, use the Model GFR1 Sprinkler Wrench. Any other type of wrench may damage these sprinklers.

Glass bulb sprinklers have orange bulb protectors to minimize bulb damage during shipping, handling and installation. REMOVE THIS PROTECTION AT THE TIME THE SPRINKLER SYSTEM IS PLACED IN SERVICE FOR FIRE PROTECTION. Removal of the protectors before this time may leave the bulb vulnerable to damage. RASCO wrenches are designed to install sprinklers when covers are in place. REMOVE PROTECTORS BY UNDOING THE CLASP BY HAND. DO NOT USE TOOLS TO REMOVE THE PROTECTORS.

Maintenance

The Models F1-300 EC Pendent and Recessed EC Pendent Sprinklers should be inspected quarterly and the sprinkler system maintained in accordance with NFPA 25. Do not clean sprinklers with soap and water, ammonia or any other cleaning fluid. Remove any sprinkler that has been painted (other than factory applied) or damaged in any way. A stock of spare sprinklers should be maintained to allow quick replacement of damaged or non-operated sprinklers. Prior to installation, sprinklers should be maintained in the original cartons and packaging until used to minimize the potential for damage to sprinklers that would cause improper operation or non-operation.

Temperature Ratings

Classification	Sprinkler Temperature		Maximum Ambient Temperature		Bulb Color
	°F	°C	°F	°C	
Ordinary	135	57	100	38	Orange
Ordinary	155	68	100	38	Red

Finishes⁽¹⁾

Standard Finishes:	
Sprinkler	Escutcheon
Bronze	Brass
Chrome Plated	Chrome Plated
White Polyester Coated ⁽²⁾	White Painted
Special Application Finishes:	
Sprinkler	Escutcheon
Bright Brass	Bright Brass
Black Plated ⁽²⁾	Black Plated
Black Paint ⁽²⁾	Black Paint
Off White	Off White
Satin Chrome	Satin Chrome
Lead Plated ⁽³⁾	Lead Plated
Wax Coated ⁽³⁾	Wax Coated
Wax Over Lead ⁽³⁾	Wax Over Lead

⁽¹⁾ Other colors are available on special order. Consult factory for details

⁽²⁾ UL and ULC Listed

⁽³⁾ 155°F (68°C) Rating Only.

Ordering Information

Specify:

1. Sprinkler Model
2. Sprinkler Type
3. Orifice Size
4. Deflector Type
5. Temperature Rating
6. Sprinkler Finish
7. Escutcheon Finish (where applicable)

Note: When Model F1-300 EC Recessed Pendent sprinklers are ordered, the sprinklers and escutcheons are packaged separately.

Reliable...For Complete Protection

Reliable offers a wide selection of sprinkler components. Following are some of the many precision-made Reliable products that guard life and property from fire around the clock.

- Automatic sprinklers
- Flush automatic sprinklers
- Recessed automatic sprinklers
- Concealed automatic sprinklers
- Adjustable automatic sprinklers
- Dry automatic sprinklers
- Intermediate level sprinklers
- Open sprinklers
- Spray nozzles
- Alarm valves
- Retarding chambers
- Dry pipe valves
- Accelerators for dry pipe valves
- Mechanical sprinkler alarms
- Electrical sprinkler alarm switches
- Water flow detectors
- Deluge valves
- Detector check valves
- Check valves
- Electrical system
- Sprinkler emergency cabinets
- Sprinkler wrenches
- Sprinkler escutcheons and guards
- Inspectors test connections
- Sight drains
- Ball drips and drum drips
- Control valve seals
- Air maintenance devices
- Air compressors
- Pressure gauges/identification signs
- Fire department connection

The equipment presented in this bulletin is to be installed in accordance with the latest published Standards of the National Fire Protection Association, Factory Mutual Research Corporation, or other similar organizations and also with the provisions of governmental codes or ordinances whenever applicable.

Products manufactured and distributed by Reliable have been protecting life and property for over 90 years, and are installed and serviced by the most highly qualified and reputable sprinkler contractors located throughout the United States, Canada and foreign countries.

Manufactured by

Reliable[®]

The Reliable Automatic Sprinkler Co., Inc.
(800) 431-1588 Sales Offices
(800) 848-6051 Sales Fax
(914) 829-2042 Corporate Offices
www.reliablesprinkler.com Internet Address



Recycled
Paper

Revision lines indicate updated or new data.

EG. Printed in U.S.A 08/10 P/N 9999970180