

Reliable®

Model G XLO Extra Large Orifice Sprinkler

Extra Large Orifice Sprinkler

(SIN R2921)

Features

The Reliable Model G XLO sprinkler offers the opportunity for:

1. Pipe size reduction
2. Fewer sprinklers
3. Elimination of booster pumps
4. Increasing densities with existing systems
5. 1/2" NPT (R1/2) available for retrofit installations only.

Listings & Approvals:

1. Listed by Underwriters Laboratories, Inc. (UL).
2. Listed by Underwriters Laboratories' of Canada (ULC).
3. Approved by Factory Mutual (FM) as a storage sprinkler.
4. NYC MEA 258-93-E (NFPA 13*).

UL Guide Number

VNIV

UL Listing Category

Sprinklers, Automatic & Open Extra Large Orifice Upright Sprinkler and Specific Application Sprinkler.

Technical Data

Sprinkler Type	Nominal K Factor		Sprinkler Height	Approvals	Sprinkler Identification Number (SIN)
	US	Metric			
Upright 0.64 Orifice with 3/4" NPT (R3/4)	11.2	160	3.14" (80mm)	1,2,3,4	R2921
Upright Retrofit 0.64 Orifice with 1/2" NPT (R1/2)	11.2	160	3.25" (83mm)	1,2,3,4	R2921

Note: This product has been tested and listed for storage applications to qualify its use in lieu of 5.6K or 8.0K Factor sprinklers for the protection of high-piled storage.

Product Description

The Reliable Model G XLO sprinkler is a center strut, solder in compression, extra large orifice upright sprinkler that has been designed to control high challenge fires in both palletized and rack storage occupancies utilizing relatively low water pressures. This sprinkler is available with either the standard 3/4" NPT (R 3/4) threads for new installations or with 1/2" NPT (R1/2) threads for retrofit applications.



It has been proven in full-scale fire testing, has complied with the applicable mechanical and hydraulic sections of the latest sprinkler standards and has Factory Mutual Approval and Underwriters Laboratories and Underwriters Laboratories' of Canada Listings.

This product is intended for use as a standard response standard spray sprinkler in hydraulically designed systems with a minimum pressure of 7 psi (0.5 bar) in accordance with the area/density curves of NFPA 13* standards.

Design Criteria

The following criteria apply when designing an automatic sprinkler system utilizing the Model G XLO sprinkler for NFPA 13* applications.

- Sprinkler spacing shall be a minimum of 6 ft. (1.8m)
- Sprinklers with 1/2" NPT (R1/2) are to be used for retrofit applications only.
- Sprinkler discharge pressure for NFPA 13* standard and all Factory Mutual (FM) applications shall be a minimum of 7 psi (0.5 bar).
- Factory Mutual (FM) Loss Prevention Data Sheets contain requirements which differ from NFPA. The Model G XLO is Approved by Factory Mutual for installations governed by Data Sheets 8-9 and 2-0.

The Model G XLO Extra Large Orifice sprinkler is intended for standard flow/pressure requirements and standard placement as specified for NFPA storage requirements. The Model G XLO sprinkler is not a "Large Drop" or "ESFR" sprinkler.

Temperature Ratings

Classification	Sprinkler Rating		Maximum Ambient Temperature		Frame Color
	°F	°C	°F	°C	
Ordinary	165	74	100	38	Uncolored
Intermediate	212	100	150	66	White
High	286	141	225	107	Blue

* For sprinkler standards prior to 1999 edition of NFPA 13, use NFPA standards 231, 231C, 231D & 231F.

Finishes

Standard Finishes	
Bronze	
Chrome	
Special Application Finishes	
Lead Plated ⁽¹⁾	- 165°F (74°C), 212°F (100°C) and 286°F (141°C) Temp. Ratings
Wax ⁽¹⁾⁽²⁾	- 165°F (74°C) Clear Wax, 212°F (100°C) Brown Wax
Wax/Lead ⁽¹⁾⁽²⁾	- 165°F (74°C) Clear Wax, 212°F (100°C) Brown Wax

⁽¹⁾ UL Listed only.

⁽²⁾ 212°F (100°C) Brown wax may be used on 286°F (141°C) Sprinklers when maximum ambient temperatures do not exceed 150°F (66°C)

Installation

Reliable's Model G XLO sprinkler must be installed according to NFPA Standards or the appropriate Factory Mutual Loss Prevention Data Sheets for all area/density methods of design as well as the Authority Having Jurisdiction.

The Model GXLO sprinkler meets the NFPA 13* standards for approval by Factory Mutual and listings by Underwriters Laboratories & Underwriters Laboratories of Canada.

* For sprinkler standards prior to 1999 edition of NFPA 13, use NFPA standards 231, 231C, 231D & 231F.

Maintenance

Model G XLO Sprinklers should be inspected quarterly and the sprinkler system maintained in accordance with NFPA 25. Do not clean sprinklers with soap and water, ammonia or any other cleaning fluids. Remove dust by using a soft brush or gentle vacuuming. Remove any sprinkler which has been painted (other than factory applied) or damaged in any way. A stock of spare sprinklers should be maintained to allow quick replacement of damaged or operated sprinklers. Prior to installation, sprinklers should be maintained in the original cartons and packaging until used to minimize the potential for damage to sprinklers that would cause improper operation or non-operation.

Ordering Information

Specify:

1. Sprinkler Model
2. Temperature Rating
3. Finishes

Model H Sprinkler



Use only the Model H sprinkler wrench for sprinkler removal and installation. Any other type of wrench may damage the sprinkler.

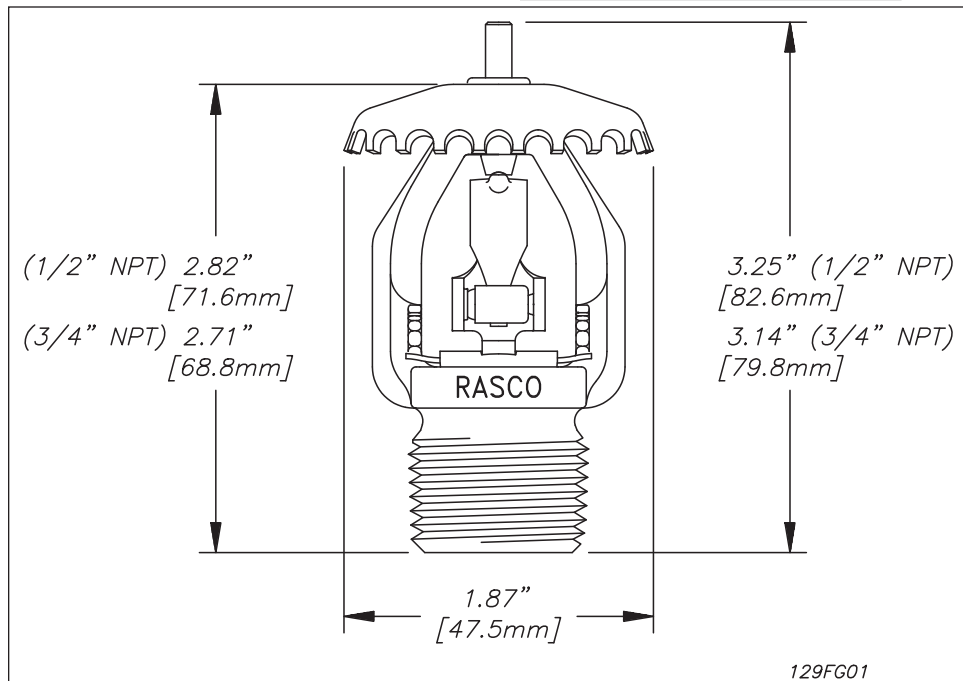

The equipment presented in this bulletin is to be installed in accordance with the latest published Standards of the National Fire Protection Association, Factory Mutual Research Corporation, or other similar organizations and also with the provisions of governmental codes or ordinances whenever applicable.

Products manufactured and distributed by Reliable have been protecting life and property for over 90 years, and are installed and serviced by the most highly qualified and reputable sprinkler contractors located throughout the United States, Canada and foreign countries.

Manufactured by

Reliable[®]

The Reliable Automatic Sprinkler Co., Inc.

(800) 431-1588

(800) 848-6051

(914) 829-2042

www.reliablesprinkler.com

Sales Offices

Sales Fax

Corporate Offices

Internet Address



Recycled Paper

Revision lines indicate updated or new data.

EG. Printed in U.S.A 06/10

P/N 9999970022