

# Reliable®

## Model F1 RES LL Residential Sprinklers for Design Density of .05 gpm/ft<sup>2</sup>

**Specifically Listed for use in Multipurpose Systems that serve both domestic water and fire protection.**

**Model F1 Res LL Sprinklers Listed for the lowest flows to meet the minimum design density of .05 gpm/ft<sup>2</sup> with potable water**

### Types:

1. F1 Res 30 LL Pendant
2. F1 Res 30 LL Recessed Pendant/F2
3. F1 Res 30 LL Recessed Pendant/FP
4. F1 Res 49 LL Pendant
5. F1 Res 49 LL Recessed Pendant/F1
6. F1 Res 49 LL Recessed Pendant/FP
7. F1 Res 58 LL Pendant
8. F1 Res 58 LL Recessed Pendant/F1
9. F1 Res 58 LL Recessed Pendant/FP
10. F1 Res 30 LL CCP Pendant
11. F1 Res 49 LL CCP Pendant
12. F1 Res 58 LL CCP Pendant
13. F1 Res 44 LL HSW
14. F1 Res 44 LL Recessed HSW/F2
15. F1 Res 58 LL HSW
16. F1 Res 58 LL HSW Recessed HSW/F2
17. F1 Res 44 LL SWC



F1 Res 30 LL, 49 LL & 58 LL  
Pendant



F1 Res 49 LL & 58 LL Recessed  
Pendant/F1  
F1 Res 30 LL  
Recessed Pendant/F2



F1 Res 49 LL & 58 LL  
Recessed Pendant/F1



F1 Res 30 LL, 49 LL & 58 LL  
CCP Pendant



F1 Res 44 LL & 58 LL  
HSW



F1 Res 44 LL & 58 LL  
Recessed HSW/F2



F1 Res 44 LL  
SWC

### Listings & Approvals

1. Listed by Underwriters Laboratories Inc. and UL Certified for Canada (cULus)
2. NSF Certified to NSF/ANSI Standard 61 Annex G (Less than 0.25% Lead Content.)

### Additional Bulletins applicable to all

#### F1RES LL Sprinklers

- Wall Wetting - Bulletin 007
- Slope Ceiling - Bulletin 035
- Design and Installation - Bulletin 140

#### UL Listing Category

Residential Automatic Sprinkler

#### UL Guide Number

VKKW

#### Patents

US Patent No. 6,516,893 applies to the Model F1 Res 49 LL & 58 LL Pendant Sprinklers  
Other patents pending.

#### Product Description

Model F1 Res LL Pendant sprinklers (Figs. 1, 2, 3, & 4) are fast response sprinklers combining excellent durability, high

sensitivity glass-bulb and low profile decorative design. The F1 Res LL Horizontal Sidewall sprinklers (Figs. 5, & 6) are equally attractive when above ceiling piping cannot be used.

The 3mm glass-bulb pendant sprinklers permit the efficient use of residential water supplies for sprinkler coverage in residential fire protection design.

The low flow F1 Res LL sprinklers are specially engineered for fast thermal response to meet the sensitive fire protection application needs of the latest residential market standards (UL 1626 Standard). Upon fire conditions, rising heat causes a sprinkler's heat-sensitive glass-bulb to shatter, releasing the waterway for water flow onto the deflector, evenly distributing the discharged water to control a fire.

#### Technical Data:

- Thermal Sensor: Nominal 3mm glass-bulb
- Sprinkler Frame : Brass
- Sprinklers' Pressure Rating : 175 psi  
Factory Hydrostatically Tested to 500 psi
- Thread Size: ½" NPT (R½)
- K-Factor: 3.0 (Actual) - F1 Res 30 LL Pendant Sprinkler  
4.9 (Actual) - F1 Res 49 LL Pendant Sprinkler  
5.8 (Actual) - F1 Res 58 LL Pendant & HSW Sprinkler  
4.4 (Actual) - F1 Res 44 LL HSW Sprinkler
- Density: Minimum 0.05 gpm/ft<sup>2</sup>

**The Reliable Automatic Sprinkler Co., Inc., 103 Fairview Park Drive, Elmsford, New York 10523**

## Application

Model F1 Res LL Sprinklers are used for Residential Fire Protection according to UL 1626 Standard\*. Be sure that orifice size, temperature rating, deflector style and sprinkler type are in accordance with the latest published standards of The National Fire Protection Association or the approving authority having jurisdiction.

- **Model F1 Res 30 LL, 49 LL & 58 LL Pendant**

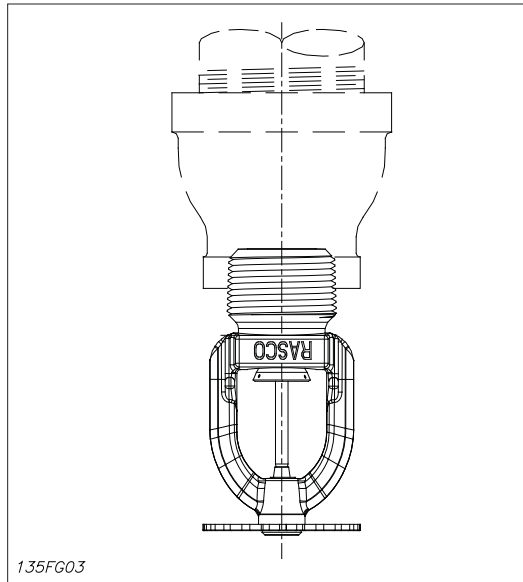

Fig. 1

## Installation

Models F1 Res LL sprinklers are to be installed as shown. Model F1, F2 and FP Escutcheons, illustrated herewith, are the only recessed escutcheons to be used with Model F1 Res LL sprinklers. Use of any other recessed escutcheon will void all approvals and warranties. For installing Model F1 Res LL Pendant sprinklers use only the Model D sprinkler Wrench; for installing Models F1 Res LL Recessed

- **Model F1 Res 30 LL Recessed Pendant / F2**
- **Model F1 Res 49 LL & 58 LL Recessed Pendant / F1**



F1 escutcheon, 3/4" (19mm) adjustment

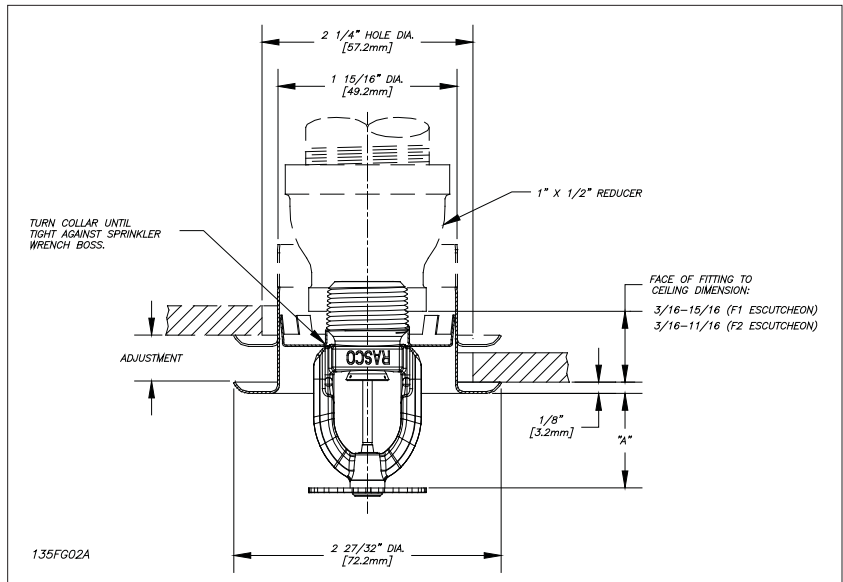

Fig. 2

Pendant, CCP & SWC sprinklers use only the Model GFR2 sprinkler wrench; for installing Model F1 LL Res Recessed HSW sprinklers use only the Model GFR2 Sprinkler Wrench. Use of wrenches other than those specified may damage these sprinklers. Install F1 Res 44 LL with a ceiling to deflector distance of 4" - 12". Flow arrow on deflector must point away from near wall and "Top" marking must face ceiling.

### Escutcheon\*, F1 or F2, Data:

Type	Adjustment Inch (mm)	"A" Inch (mm)	Face of fitting to ceiling Inch (mm)
F1	3/4 (19.0)	Min.=3/4" (19.1) Max.=1 1/2" (38.1)	3/16 - 15/16 (4.7 - 24.0)
F2	1/2 (12.7)	Min.=15/16" (23.8) Max.=1 1/2" (38.1)	3/16 - 11/16 (4.7 - 17.4)

\* Note: Escutcheons F1 or F2 may be used with Model F1 Res 49 LL & 58 LL Recessed Pendant Sprinkler

**Technical Data: F1Res 30 LL Pendant and Recessed Pendant**

Thread Size	Nominal Orifice Inch (mm)	Sprinkler Temp. Rating		Max. Pressure psi (bar)	Max. Ambient Temp.		Actual K Factor	Sprinkler Length Inch (mm)
		°F	°C		°F	°C		
½" NPT (R½)	2 1/64" (8.2)	155	68	175 (12)	100	38	3.0	2.25 (57)
		175	79					

**Deflector - to - ceiling  
Maximum 1" (25mm) to 4" (100mm)**

Max. Sprinkler Spacing ft (m)	Flow gpm (Lpm)	Pressure psi (bar)	Sprinkler Identification Number (SIN)
12 x 12 (3,6 x 3,6)	8 (30.3)	7.0 (0,48)	RA3311
14 x 14 (4,3 x 4,3)	10 (37.8)	11 (0,76)	

**Technical Data: F1Res 49 LL Pendant and Recessed Pendant.**

Thread Size	Nominal Orifice Inch (mm)	Sprinkler Temp. Rating		Max. Pressure psi (bar)	Max. Ambient Temp.		Actual K Factor	Sprinkler Length Inch (mm)
		°F	°C		°F	°C		
½" NPT (R½)	7/16" (11)	155	68	175 (12)	100	38	4.9	2.25 (57)
		175	79		150	66		

**Deflector - to - ceiling  
Maximum 1" (25mm) to 4" (100mm)**

Max. Sprinkler Spacing ft (m)	Flow gpm (Lpm)	Pressure psi (bar)	Sprinkler Identification Number (SIN)
12 x 12 (3,6 x 3,6)	13 (49)	7.0 (0,48)	RA3316
14 x 14 (4,3 x 4,3)	13 (49)	7.0 (0,48)	
16 x 16 (4,9 x 4,9)	13 (49)	7.0 (0,48)	
18 x 18 (5,5 x 5,5)	17 (64.3)	12.0 (0,83)	
20 x 20 (6,1 x 6,1)	20 (75.7)	16.7 (1,14)	

**Deflector - to - ceiling  
Maximum 4" (100mm) to 8" (203mm)**

Max. Sprinkler Spacing ft (m)	Flow gpm (Lpm)	Pressure psi (bar)	Sprinkler Identification Number (SIN)
12 x 12 (3,6 x 3,6)	15 (57)	9.4 (0,65)	RA3316
14 x 14 (4,3 x 4,3)	16 (60.5)	10.6 (0,73)	
16 x 16 (4,9 x 4,9)	17 (64.3)	12.0 (0,83)	
18 x 18 (5,5 x 5,5)	19 (72)	15.0 (1,0)	
20 x 20 (6,1 x 6,1)	22 (83.2)	20.2 (1,4)	

**\*Note:** The F1 Res 49 LL pendant and recessed pendant residential sprinklers can be installed per NFPA 13 in beamed ceilings meeting the following criteria:  
 1. Maximum beam depth = 7" (178mm)  
 2. Beam spacing at or greater than 7.5 ft. (2.3m) on center.

**Technical Data: F1Res 58 LL Pendant and Recessed Pendant.**

Thread Size	Nominal Orifice Inch (mm)	Sprinkler Temp. Rating		Max. Pressure psi (bar)	Max. Ambient Temp.		Actual K Factor	Sprinkler Length Inch (mm)
		°F	°C		°F	°C		
½" NPT (R½)	½" (13)	155	68	175 (12)	100	38	5.8	2.25 (57)
		175	79		150	66		

Max. Sprinkler Spacing ft (m)	Flow gpm (Lpm)	Pressure psi (bar)	Ceiling -to- Deflector Inch (mm)	Sprinkler Identification Number (SIN)
12 x 12 (3,6 x 3,6)	16 (61)	7.6 (0,53)	1- 4 (25 - 100)	RA3313
14 x 14 (4,3 x 4,3)	16 (61)	7.6 (0,53)		
16 x 16 (4,9 x 4,9)	16 (61)	7.6 (0,53)		
18 x 18 (5,5 x 5,5)	19 (72)	10.8 (0,75)		
20 x 20 (6,1 x 6,1)	22 (83.3)	14.4 (1,0)		

- Model F1 Res 30 LL, 49 LL & 58 LL CCP Pendant



- Model F1 Res 30 LL, 49 LL & 58 LL Recessed Pendant / FP



FP push-on/thread-off escutcheon

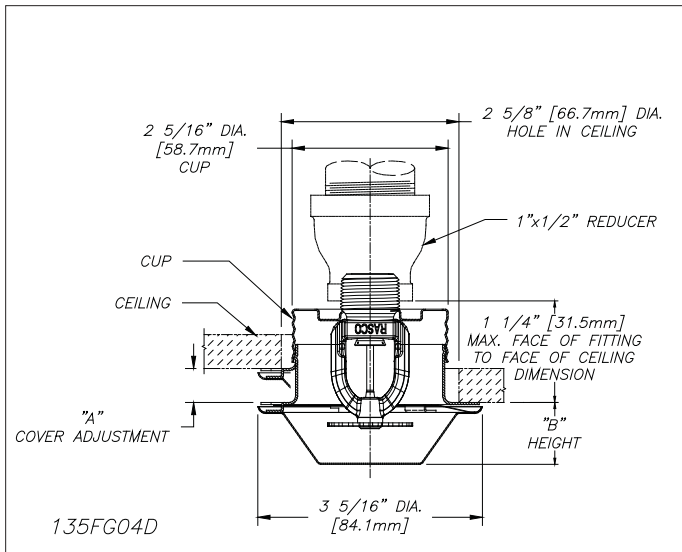

Fig. 3

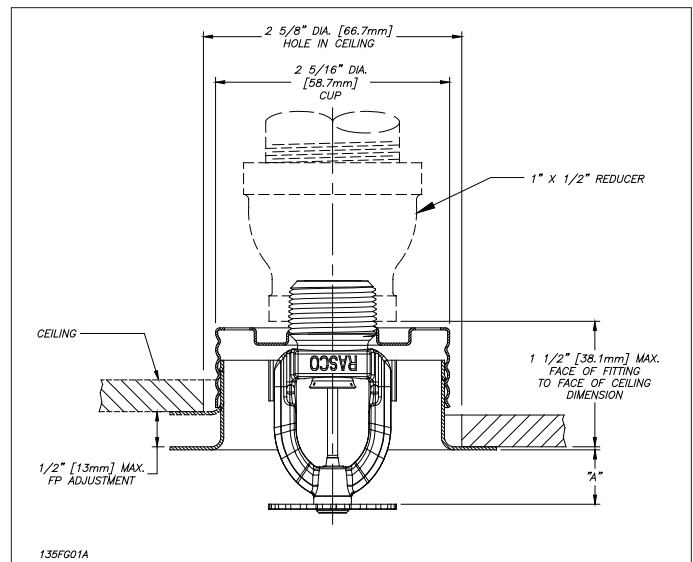

Fig. 4

**Technical Data: F1Res 30 LL CCP Pendant and Recessed Pendant/FP**

Thread Size	Nominal Orifice Inch (mm)	Sprinkler Temp. Rating		CCP Assembly Temp. Rating		Max. Pressure psi (bar)	Max. Ambient Temp.		K Factor	Sprinkler Length Inch (mm)
		°F	°C	°F	°C		°F	°C		
1/2" NPT (R1/2)	21/64" (8.2)	155	68	135	57	175 (12)	100	38	3.0	2.25 (57)

Max. Sprinkler Spacing ft (m)	Flow gpm (Lpm)	Pressure psi (bar)	Sprinkler Identification Number (SIN)
12 x 12 (3,6 x 3,6)	8 (30.3)	7.0 (0,48)	RA3311
14 x 14 (4,3 x 4,3)	11 (41.6)	13.4 (0,92)	

**Technical Data: F1Res 49 LL CCP Pendant and Recessed Pendant/FP**

Thread Size	Nominal Orifice Inch (mm)	Sprinkler Temp. Rating		CCP Assembly Temp. Rating		Max. Pressure psi (bar)	Max. Ambient Temp.		K Factor	Sprinkler Length Inch (mm)
		°F	°C	°F	°C		°F	°C		
1/2" NPT (R1/2)	7/16" (11)	155	68	135	57	175 (12)	100	38	4.9	2.25 (57)

**CCP Options Data:**

"A" Cover Adjustment Inch (mm)	"B" CCP Height Inch (mm)
1/2 (12.7)	15/16 (24)
5/16 (7.9)	3/4 (19)

Max. Sprinkler Spacing ft (m)	Flow gpm (Lpm)	Pressure psi (bar)	Sprinkler Identification Number (SIN)
12 x 12 (3,6 x 3,6)	13 (49)	7.0 (0,48)	RA3316
14 x 14 (4,3 x 4,3)	13 (49)	7.0 (0,48)	
16 x 16 (4,9 x 4,9)	14 (53)	8.2 (0,56)	
18 x 18 (5,5 x 5,5)	18 (68.1)	13.5 (0,93)	
20 x 20 (6,1 x 6,1)	20 (75.7)	16.7 (1,14)	

**FP Data "A":**

FP Position	"A" Inch (mm)
Max. Recessed	7/16 (11)
Min. Recessed	15/16 (24)

**Note:** Sprinklers shown in Fig. 3 and Fig. 4 are not suitable for installation in ceilings which have positive pressure in the space above.

**Technical Data: F1Res 58 LL CCP Pendant and Recessed Pendant/FP**

Thread Size	Nominal Orifice Inch (mm)	Sprinkler Temp. Rating		CCP Assembly Temp. Rating		Max. Pressure psi (bar)	Max. Ambient Temp.		K Factor	Sprinkler Length Inch (mm)
		°F	°C	°F	°C		°F	°C		
1/2" NPT (R1/2)	1/2" (13)	155	68	135	57	175 (12)	100	38	5.8	2.25 (57)

Max. Sprinkler Spacing ft (m)	Flow gpm (Lpm)	Pressure psi (bar)	Sprinkler Identification Number (SIN)
12 x 12 (3,6 x 3,6)	16 (61)	7.6 (0,53)	RA3313
14 x 14 (4,3 x 4,3)	16 (61)	7.6 (0,53)	
16 x 16 (4,9 x 4,9)	16 (61)	7.6 (0,53)	
18 x 18 (5,5 x 5,5)	19 (72)	10.8 (0,75)	
20 x 20 (6,1 x 6,1)	22 (83.3)	14.4 (1,0)	

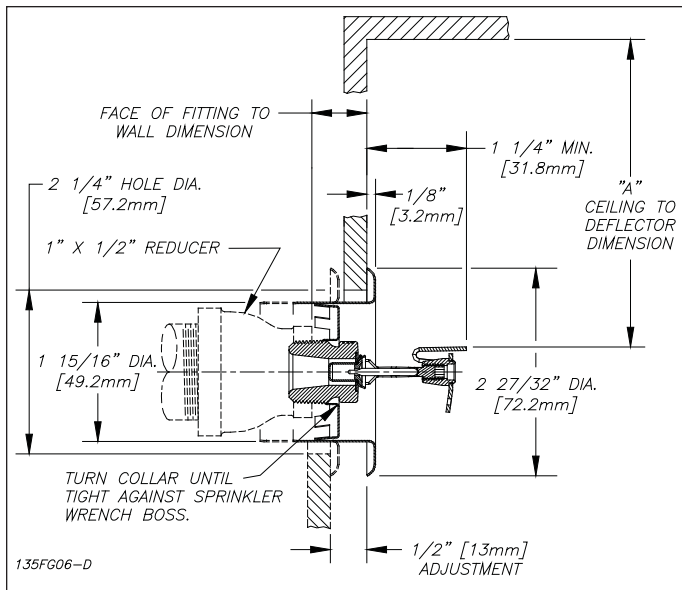
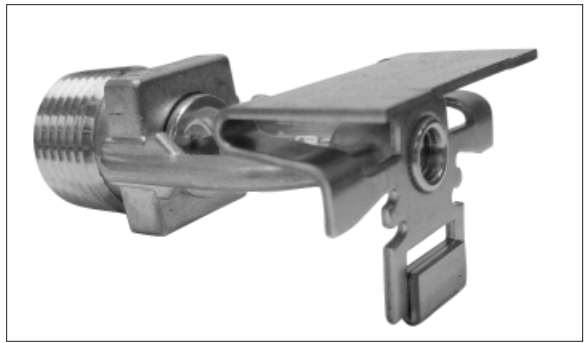

Fig. 5

• Model F1 Res 44 LL & 58 LL HSW



• Model F1 Res 44 LL & 58 LL Recessed HSW/F2



F2 escutcheon,  
1/2" (13mm) adjustment

Technical Data: F1Res 44 LL HSW & HSW/F2

Thread Size	Nominal Orifice Inch (mm)	Sprinkler Temp. Rating		Max. Pressure psi (bar)	Max. Ambient Temp.		K Factor	Sprinkler Length Inch (mm)
		°F	°C		°F	°C		
1/2" NPT (R1/2)	3/8" (10)	155	68	175 (12)	100	38	4.4	2.45 (62)
		175	79		150	66		

Escutcheon, F2, Data:

Type	Adjustment Inch (mm)	Face of Fitting to wall Inch (mm)
F2	1/2 (13)	3/16 - 11/16 (4.7 - 17.4)

Max. Sprinkler Spacing ft (m)	"A" Ceiling to Deflector Inch (mm)	Sprinkler Temp. Rating °F (°C)		Flow gpm (Lpm)	Pressure psi (bar)	Sprinkler Identification Number (SIN)
		°F	°C			
12 x 12 (3,6 x 3,6)	4 - 6 (101 - 152)	155 (68)	175 (79)	12 (45,4)	7.5 (0,52)	RA3331
14 x 14 (4,3 x 4,3)		155 (68)	175 (79)	14 (53,0)	10.2 (0,71)	
16 x 16 (4,9 x 4,9)		155 (68)	175 (79)	16 (60,6)	13.3 (0,92)	
16 x 18 (4,9 x 5,5)		155 (68)	175 (79)	18 (68,1)	16.8 (1,16)	
18 x 18 (5,5 x 5,5)		155 (68)	175 (79)	19 (72,0)	18.7 (1,29)	
16 x 20 (4,9 x 6,1)		155 (68)	175 (79)	23 (87,1)	27.4 (1,89)	
12 x 12 (3,6 x 3,6)	6 - 12 (152 - 305)	155 (68)	175 (79)	14 (53,0)	10.2 (0,71)	
14 x 14 (4,3 x 4,3)		155 (68)	175 (79)	16 (60,6)	13.3 (0,92)	
16 x 16 (4,9 x 4,9)		155 (68)	175 (79)	17 (64,4)	15.0 (1,04)	
16 x 18 (4,9 x 5,5)		155 (68)	175 (79)	20 (75,7)	20.7 (1,43)	
16 x 18 (4,9 x 5,5)		155 (68)	175 (79)	20 (75,7)	20.7 (1,43)	
16 x 20 (4,9 x 6,1)		155 (68)	175 (79)	23 (87,1)	27.4 (1,89)	

**Technical Data: F1Res 58 LL HSW & HSW/F2**

Thread Size	Nominal Orifice Inch (mm)	Sprinkler Temp. Rating		Max. Pressure psi (bar)	Max. Ambient Temp.		K Factor	Sprinkler Length Inch (mm)
		°F	°C		°F	°C		
1/2" NPT (R1/2)	1/2" (13)	155 175	68 79	175 (12)	100 150	38 66	5.8	2.45 (62)

**Escutcheon, F2, Data:**

Type	Adjustment Inch (mm)	Face of Fitting to wall Inch (mm)
F2	1/2 (13)	3/16 - 11/16 (4.7 - 17.4)

Max. Sprinkler Spacing ft (m)	"A" Ceiling to Deflector Inch (mm)	Sprinkler Temp. Rating °F (°C)		Flow gpm (Lpm)	Pressure psi (bar)	Sprinkler Identification Number (SIN)
12 x 12 (3,6 x 3,6)	4 - 6 (101 - 152)	155 (68)	175 (79)	16 (60,6)	7.6 (0,53)	RA3333
14 x 14 (4,3 x 4,3)		155 (68)	175 (79)	18 (68,2)	9.7 (0,67)	
16 x 16 (4,9 x 4,9)		155 (68)	175 (79)	21 (79,5)	13.2 (0,91)	
16 x 18 (4,9 x 5,5)		155 (68)	175 (79)	25 (94,7)	18.6 (1,28)	
16 x 20 (4,9 x 6,1)		155 (68)	175 (79)	29 (109,8)	25 (1,73)	
12 x 12 (3,6 x 3,6)	6 - 12 (152 - 305)	155 (68)	175 (79)	22 (83,3)	14.4 (1,0)	
14 x 14 (4,3 x 4,3)		155 (68)	175 (79)	22 (83,3)	14.4 (1,0)	
16 x 16 (4,9 x 4,9)		155 (68)	175 (79)	26 (98,4)	20.1 (1,39)	
16 x 18 (4,9 x 5,5)		155 (68)	175 (79)	31 (117,4)	28.6 (1,97)	

• **Model F1 Res 44 LL SWC**

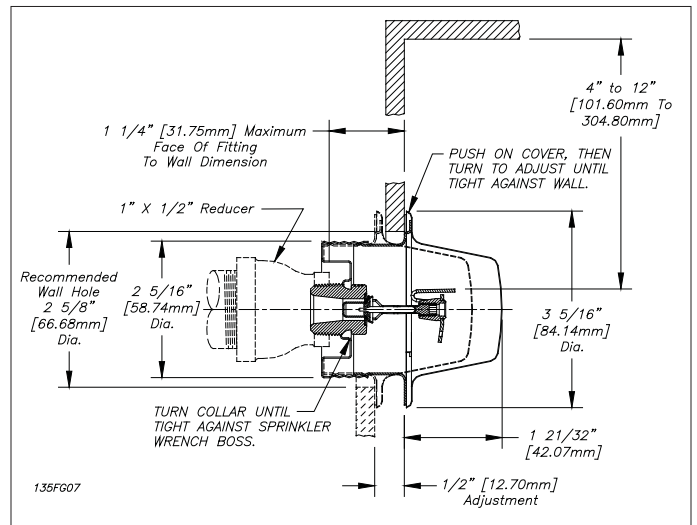
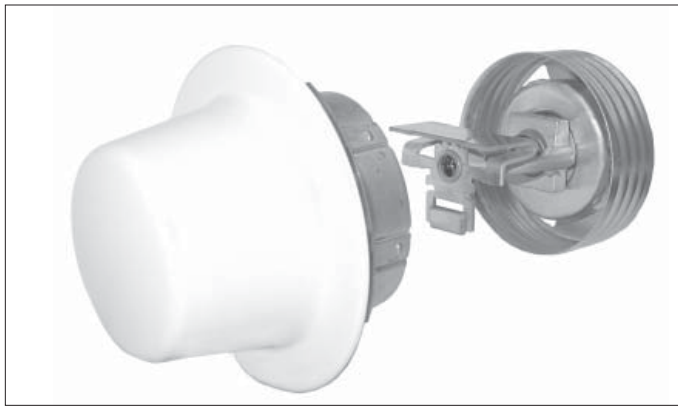

Fig. 6

**Technical Data: F1Res 44 LL SWC**

Thread Size	Nominal Orifice Inch (mm)	Sprinkler Temp. Rating		Cover Temp. Rating		Max. Pressure psi (bar)	Max. Ambient Temp.		K Factor	Sprinkler Length Inch (mm)
		°F	°C	°F	°C		°F	°C		
1/2" NPT (R1/2)	3/8" (10)	155	68	135	57	175 (12)	100	38	4.4	2.45 (62)

Max. Sprinkler Spacing ft (m)	"A" Ceiling to Deflector Inch (mm)	Flow gpm (Lpm)	Pressure psi (bar)	Sprinkler Identification Number (SIN)
12 x 12 (3,6 x 3,6)	4 - 6 (101 - 152)	13 (49,2)	8.7 (0,60)	RA3331
14 x 14 (4,3 x 4,3)		14 (53,0)	10.2 (0,71)	
16 x 16 (4,9 x 4,9)		17 (64,3)	15.0 (1,1)	
16 x 18 (4,9 x 5,5)		19 (71,8)	18.7 (1,13)	
16 x 20 (4,9 x 6,1)		23 (87,1)	27.4 (1,89)	
12 x 12 (3,6 x 3,6)	6 - 12 (152 - 305)	14 (52,9)	10.2 (0,71)	
14 x 14 (4,3 x 4,3)		15 (56,7)	11.7 (0,81)	
16 x 16 (4,9 x 4,9)		18 (68,1)	16.8 (1,16)	
16 x 18 (4,9 x 5,5)		20 (75,6)	20.7 (1,43)	

## Maintenance

Model F1 Res 30 LL, 49 LL, F1 Res 58 LL and F1 Res 44 LL Sprinklers should be inspected quarterly, and the sprinkler system maintained in accordance with NFPA 25, 13, 13D, and 13R. Do not clean sprinkler with soap and water, Ammonia or any other cleaning fluids. Remove dust by using a soft brush or gentle vacuuming. Remove any sprinkler which has been painted (other than factory applied) or damaged in any way. A stock of spare sprinklers should be maintained to allow quick replacement of damaged or operated sprinklers. Prior to installation, sprinklers should remain in the original cartons and packaging until used. This will minimize the potential for damage to sprinklers that could cause improper operation or non-operation.

### **Model F1 Res 30 LL, 49 LL & 58 LL Pendent Sprinkler Specifications**

Sprinklers shall be [cULus Listed] [New York City MEA Approved (258-93-E)] low flow residential pendent sprinklers engineered to provide a minimum design density of 0.05 gpm/ft<sup>2</sup> over the listed coverage area. Listed flows as specified by the manufacturer's technical data sheets are to be used. Residential sprinklers shall be installed in conformance with the manufacturer's installation guidelines and the applicable installation standard. Where pendent residential sprinklers are installed under sloped ceilings having a pitch from [4/12] to [8/12], the sprinklers shall be listed for such use. Deflector-to-ceiling distance listing shall be 1" to 8" maximum. Sprinkler frame and deflector shall be of bronze frame construction having a ½" NPT thread. Water seal assembly shall consist of a Teflon-coated Belleville spring washer with top-loaded extruded or cold head cup with 3 mm glass bulb containing no plastic parts, and having a temperature rating of [155°F (68°C)] [175°F (79°C)]. Sprinklers shall have a nominal K-factor of 3.0, 4.9 and 5.8. Standard finish: [Bronze] [Chrome-plated] [White Polyester] [Special finish– specify]. Residential pendent sprinklers shall be Reliable Model F1 Res 30 LL, 49 LL & 58 LL, SIN RA3311, RA3316 & RA3313 (Bulletin 033).

### **Model F1 Res 49 LL & 58 LL Recessed Pendent/F1**

### **Model F1 Res 30 LL, 49 LL & 58 LL Recessed Pendent/F2**

### **Model F1 Res 30 LL, 49 LL & 58 LL Recessed Pendent/FP Specifications**

Sprinklers shall be [cULus Listed] [New York City MEA Approved (258-93-E)] low flow residential recessed pendent sprinklers engineered to provide a minimum design density of 0.05 gpm/ft<sup>2</sup> over the listed coverage area. Listed flows as specified by the manufacturer's technical data sheets are to be used. Residential sprinklers shall be installed in conformance with the manufacturer's installation guidelines and the applicable installation standard. Where

pendent residential sprinklers are installed under sloped ceilings having a pitch from [4/12] to [8/12], the sprinklers shall be listed for such use. Deflector-to-ceiling distance listing shall be 1" to 8" maximum. Sprinkler frame and deflector shall be of bronze frame construction having a ½" NPT thread. Water seal assembly shall consist of a Teflon-coated Belleville spring washer with top-loaded extruded or cold head cup with 3 mm glass bulb containing no plastic parts, and having a temperature rating of [155°F (68°C)] [175°F (79°C)]. Sprinklers shall have a nominal K-factor of 3.0, 4.9 & 5.8. Standard finish: [Bronze] [Chrome-plated] [White Polyester] [Special finish– specify]. Recessed escutcheon assembly shall be a steel, two-piece escutcheon [with ½" adjustment (Model F2)] [with ¾" adjustment (Model F1)] [of push-on and thread off design with ½" adjustment (Model FP)]. Standard finish shall be [brass][bright chrome] [white painted]. Residential recessed pendent sprinklers shall be Reliable [Model F1 Res 30 LL, 49 LL & 58 LL Recessed Pendent/F1] [Model F1 Res 30 LL, 49 LL & 58 LL Recessed Pendent/F2] [Model F1 Res 30 LL, 49 LL & 58 LL Recessed Pendent/FP] SIN RA3311, RA3316 & RA3313 (Bulletin 033).

### **Model F1 Res 30 LL, 49 LL & 58 LL CCP Pendent (Concealed) Specifications**

Sprinklers shall be [cULus Listed] [New York City MEA Approved (258-93-E)] low flow residential concealed sprinklers engineered to provide a minimum design density of 0.05 gpm/ft<sup>2</sup> over the listed coverage area. Listed flows as specified by the manufacturer's technical data sheets are to be used. Residential sprinklers shall be installed in conformance with the manufacturer's installation guidelines and the applicable installation standard. Where pendent residential sprinklers are installed under sloped ceilings having a pitch from [4/12] to [8/12], the sprinklers shall be listed for such use. Sprinkler frame and deflector shall be of bronze frame construction having a ½" NPT thread. Water seal assembly shall consist of a Teflon-coated Belleville spring washer with top-loaded extruded or cold head cup with 3 mm glass bulb containing no plastic parts, and having a temperature rating of 155°F (68°C). Cover plate assembly shall consist of a brass cover plate and copper alloy retainer flange. Method of attaching the cover plate to the sprinkler cup shall be a push-on and thread-off design allowing a ½" cover plate adjustment. Cover plate temperature rating shall be 135°F (57°C). A plastic protective cap shall be provided and factory installed inside the sprinkler cup to protect the sprinkler from damage, which could occur during construction before the cover plate is installed. Standard cover plate finish: [White] [Custom Color– specify]. Concealed pendent sprinklers shall be Reliable Model F1 Res 30 LL, 49 LL & 58 LL CCP, SIN RA3311, RA3316 & RA3313 (Bulletin 033).

**Model F1 Res 44 LL Horizontal Sidewall Residential Sprinkler Specifications**

Sprinklers shall be [cULus Listed] [New York City MEA Approved (258-93-E)] low flow residential horizontal sidewall sprinklers engineered to provide a minimum design density of 0.05 gpm/ft<sup>2</sup> over the listed coverage area. Listed flows as specified by the manufacturer’s technical data sheets are to be used. Residential sprinklers shall be installed in conformance with the manufacturer’s installation guidelines and the applicable installation standard. Where horizontal sidewall residential sprinklers are installed under sloped ceilings having a pitch from [4/12] to [8/12], the sprinklers shall be listed for such use. Sprinkler frame and deflector shall be of bronze frame construction having a ½” NPT thread. Water seal assembly shall consist of a Teflon-coated Belleville spring washer with top-loaded extruded or cold head cup with 3 mm glass bulb containing no plastic parts, and having a temperature rating of [155°F (68°C)] [175°F (79°C)]. Sprinklers shall have a nominal K-factor of 4.4 (62.8). Standard finish: [Bronze] [Chrome-plated] [White Polyester] [Special finish– specify]. Residential horizontal sidewall sprinklers shall be Reliable Model F1 Res 44 LL, SIN RA3331 (Bulletin 033).

**Model F1 Res 44 LL Recessed Horizontal Sidewall Sprinkler Specifications**

Use description for the Model F1 Res 44 horizontal sidewall sprinkler with the following modifications: Replace “horizontal sidewall sprinkler” with “recessed horizontal sprinkler.” Add: Recessed escutcheon assembly shall be a steel, two-piece escutcheon with ½” adjustment (Model F2). Standard finish shall be [brass][bright chrome] [white painted] [Special finish– specify]. Residential recessed horizontal sidewall sprinklers shall be Reliable Model F1 Res 44 LL/F2, SIN RA3331 (Bulletin 033).

**Finishes <sup>(1)</sup>**

Standard Finishes		
Sprinkler	F1, F2, FP Escutcheons	Cover Plates
Bronze Chrome Plated White and Black Polyester Coated	Brass Bright Chrome Plated White Painted	White Painted Chrome
Special Application Finishes		
Sprinkler	F1, F2, Escutcheons	Cover Plates
Bright Brass Black Plated Black Paint Off White Satin Chrome	Bright Brass Black Plated Black Paint Off White Satin Chrome	Bright Brass Black Plated Black Paint Off White Satin Chrome

<sup>(1)</sup> Other finishes and colors are available on special order. Consult factory for details.

**Note:** Paint or any other coating applied over the factory finish will void all approvals and warranties.

**Ordering Information**

**Specify:**

1. Sprinkler Model
2. Sprinkler Type
3. Temperature Rating
4. Sprinkler Finish
5. Escutcheon Finish
6. Cover Plate Finish

# Reliable...For Complete Protection

Reliable offers a wide selection of sprinkler components. Following are some of the many precision-made Reliable products that guard life and property from fire around the clock.

- Automatic sprinklers
- Flush automatic sprinklers
- Recessed automatic sprinklers
- Concealed automatic sprinklers
- Adjustable automatic sprinklers
- Dry automatic sprinklers
- Intermediate level sprinklers
- Open sprinklers
- Spray nozzles
- Alarm valves
- Retarding chambers
- Dry pipe valves
- Accelerators for dry pipe valves
- Mechanical sprinkler alarms
- Electrical sprinkler alarm switches
- Water flow detectors
- Deluge valves
- Detector check valves
- Check valves
- Electrical system
- Sprinkler emergency cabinets
- Sprinkler wrenches
- Sprinkler escutcheons and guards
- Inspectors test connections
- Sight drains
- Ball drips and drum drips
- Control valve seals
- Air maintenance devices
- Air compressors
- Pressure gauges
- Identification signs
- Fire department connection

---

The equipment presented in this bulletin is to be installed in accordance with the latest published Standards of the National Fire Protection Association, Factory Mutual Research Corporation, or other similar organizations and also with the provisions of governmental codes or ordinances whenever applicable.

Products manufactured and distributed by Reliable have been protecting life and property for over 90 years, and are installed and serviced by the most highly qualified and reputable sprinkler contractors located throughout the United States, Canada and foreign countries.

---

Manufactured by

**Reliable**<sup>®</sup>

The Reliable Automatic Sprinkler Co., Inc.  
(800) 431-1588 Sales Offices  
(800) 848-6051 Sales Fax  
(914) 829-2042 Corporate Offices  
www.reliablesprinkler.com Internet Address



Revision lines indicate updated or new data.

EG. Printed in U.S.A 08/11 P/N 9999970411