

# Reliable®

## Model F1FR56 QREC Series Quick Response Extended Coverage Spray

**A complete line of UL Listed and FM Approved quick response extended coverage sprinklers for light hazard applications.**

**Horizontal Sidewall Sprinklers are approved for installation 4" to 12" (102mm - 305mm)**

### Model F1FR56 QREC Sprinkler Types

Pendent

Horizontal Sidewall EC-8

### Model F1FR56 QREC Recessed Sprinkler Types

Recessed Extended Coverage Pendent F1/F2/FP

Recessed Extended coverage Horizontal Sidewall

### Model F1FR56 QREC Concealed

Extended Coverage Pendent

### Approval Organizations

1. Listed by Underwriters Laboratories, Inc. and Certified for Canada (cULus)
2. Factory Mutual Approvals (FM)

### UL Listing Category

Sprinklers, Automatic & Open

Quick Response Extended Coverage Sprinkler (VNIV)

### Product Description

Reliable Models F1FR56 QREC and F1FR56 QREC Recessed Sprinklers are quick response sprinklers which combine the durability for a standard sprinkler with the attractive low profile of a decorative sprinkler.

The Models F1FR56 QREC and F1FR56 QREC Recessed Automatic Sprinklers utilize a 3.0mm frangible glass bulb. These sprinklers have demonstrated response times in laboratory tests which are five times faster than standard response sprinklers. This quick response enables these sprinklers to apply water to a fire much faster than standard sprinklers of the same temperature rating.

Model F1FR56 QREC Quick Response Extended Coverage Concealed Sprinkler is an attractive, low profile concealed sprinkler assembly. This sprinkler assembly utilizes a Model F1FR56 QREC pendent sprinkler in a Model CCP cup and push-on thread-off cover plate assembly. The cup is securely factory threaded on the sprinkler's inlet end. The assembly is shipped with a protective cap. The sprinkler and cup are easily installed into the sprinkler fitting using the Model RC1 Sprinkler Wrench. The cover plate assembly is attached to the sprinkler cup using a flexible tooth threaded engagement. The cover plate is attached to the skirt using 135°F (57°C) ordinary temperature classification solder.



Extended Coverage  
Pendent



Recessed Extended  
Coverage Pendent F1/F2



Extended Coverage  
Pendent Concealed



Extended Coverage  
Horizontal Sidewall EC-8



Recessed Extended  
Coverage Horizontal  
Sidewall EC-8

When the ceiling temperature rises, the solder holding the cover plate melts, allowing the release of this part and thus exposing the Model F1FR56 QREC sprinkler inside to the rising ambient temperature.

The Temperature rating of the sprinkler identified by the color of the glass bulb.

The glass bulb consists of an accurately controlled amount of special fluid hermetically sealed inside a precisely manufactured glass capsule. This glass bulb is specially constructed to provide fast thermal response.

### Application

Quick response sprinklers are used in fixed fire protection systems: Wet, Dry, Deluge or Preaction. Care must be exercised that the orifice size, temperature rating, deflector style and sprinkler type are in accordance with the latest published standards of the National Fire Protection Association or the approving authority having jurisdiction. Quick response sprinklers are intended for installation as specified in NFPA 13.

**The Reliable Automatic Sprinkler Co., Inc., 103 Fairview Park Drive, Elmsford, New York 10523**

# Model F1FR56 Quick Response Extended Coverage Pendant Sprinkler

**Deflector:** EC

**Installation Wrench:** Model D Sprinkler Wrench

**Approval Type:** Quick Response Extended Coverage - Light Hazard Occupancy



## Installation Data:

Nominal Orifice	Thread Size	"K" Factor		Sprinkler Length	Approval Organizations	Temperature Rating		Sprinkler Identification Numbers (SIN)
		US	Metric			°F	°C	
1/2" (15mm)	1/2" NPT (R1/2)	5.6	80	2.25" (57mm)	1	135 155	57 68	RA2845

Table 1

Coverage Area				
Flow Rate		Pressure psi (bar)	Max. Area Width x Length	
gpm	L/min	K=5.6 (80)	ft. x ft.	m x m
26	98.4	21.6 (1,5)	16 x 16	4.9 x 4.9
33	125.0	34.7 (2,4)	18 x 18	5.5 x 5.5
40	151.4	51.0 (3,5)	20 x 20	6.0 x 6.0 <sup>(1)</sup>

<sup>(1)</sup> 135°F (57°C) only.

# Model F1FR56 Recessed Quick Response Extended Coverage Pendant Sprinkler

**Deflector:** EC

**Installation Wrench:** Model GFR2 Sprinkler Wrench

**Approval Type:** Quick Response Extended Coverage - Light Hazard Occupancy

## Installation Data:

Nominal Orifice	Thread Size	"K" Factor		Sprinkler Length	Approval Organizations	Temperature Rating		Sprinkler Identification Numbers (SIN)
		US	Metric			°F	°C	
1/2" (15mm)	1/2" NPT (R1/2)	5.6	80	2.25" (57mm)	1	135 155	57 68	RA2845

<sup>(1)</sup> See table 1 for Coverage Area.

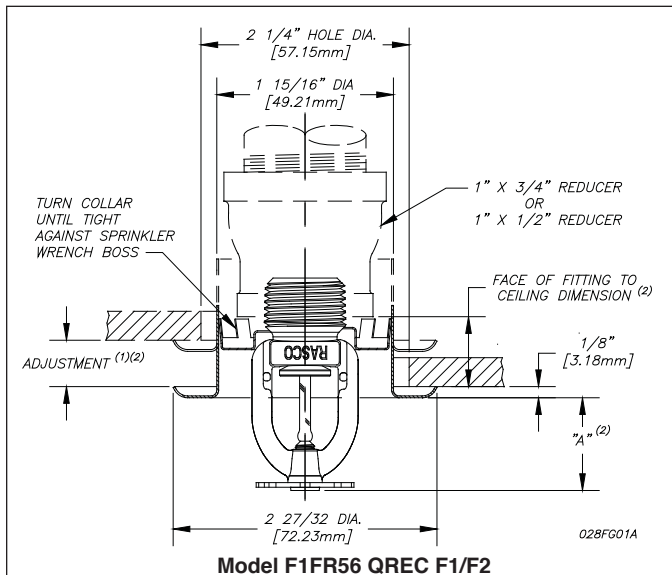

Fig. 1

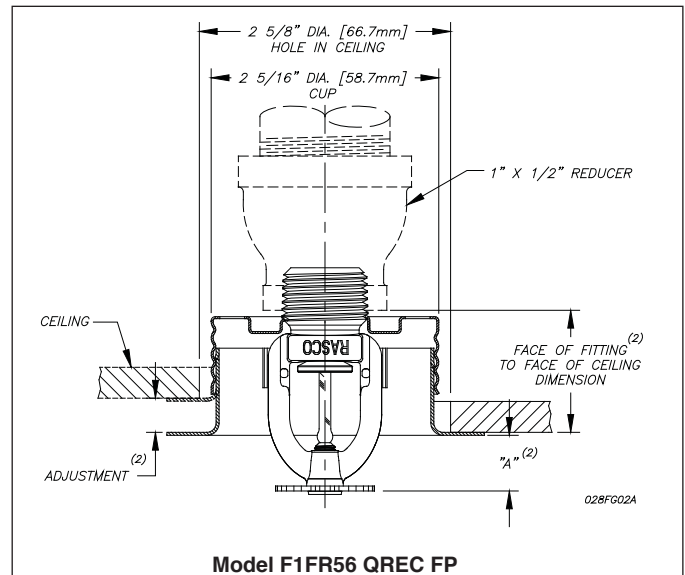

Fig. 2

<sup>(1)</sup> When installed directly into a tee, the escutcheon adjustment will be reduced.

<sup>(2)</sup> Refer to escutcheon data table for approvals and dimensions.

## Model F1FR56 Quick Response Extended Coverage Horizontal Sidewall Sprinkler

**Deflector:** EC-8

**Installation Wrench:** Model D Sprinkler Wrench

**Approval Type:** Quick Response Extended Coverage-Light Hazard Occupancy

### Installation Data:

Nominal Orifice	Thread Size	"K" Factor		Sprinkler Length	Approval Organizations	Temperature Rating	Sprinkler Identification Number (SIN)
		US	Metric				
1/2" (15mm)	1/2" NPT (R1/2)	5.6	80	2.86" (73mm)	1, 2	135°F (57°C) 155°F (68°C) 175°F (79°C)	RA2865



## Model F1FR56 Recessed Quick Response Extended Coverage Horizontal Sidewall Sprinkler

**Deflector:** EC-8

**Installation Wrench:** Model GFR2 Sprinkler Wrench

**Approval Type:** Quick Response Extended Coverage-Light Hazard Occupancy

### Installation Data:

Nominal Orifice	Thread Size	"K" Factor		Sprinkler Length	Approval <sup>(2)</sup> Organizations	Temperature <sup>(1)</sup> Rating	Sprinkler Identification Number (SIN)
		US	Metric				
1/2" (15mm)	1/2" NPT (R1/2)	5.6	80	2.86" (73mm)	1, 2	135°F (57°C) 155°F (68°C) 175°F (79°C)	RA2865

<sup>(1)</sup> FM Approval of recessed sprinkler - 135°F (57°C) only

<sup>(2)</sup> Refer to escutcheon data table for approvals and dimensions.

COVERAGE AREA					
Flow Rate gpm (L/min)		Pressure psi (bar)		Maximum Coverage Area Width x Length ft. x ft. (m x m)	Deflector to Ceiling Dimension Min. - Max. Inches (mm)
UL	FM	UL	FM		
26 (98.4)	26 (98.4)	21.4 (1,5)	21.4 (1,5)	16 x 16 (4.9 x 4.9)	4 - 12 (102 - 305)
29 (109.8)	30 (113.6)	26.6 (1,8)	28.5 (2,0)	16 x 18 (4.9 x 5.5)	4 - 12 (102 - 305)
32 (121.1)	33 (125.0)	32.4 (2,2)	34.5 (2,4)	16 x 20 (4.9 x 6.0)	4 - 12 (102 - 305)

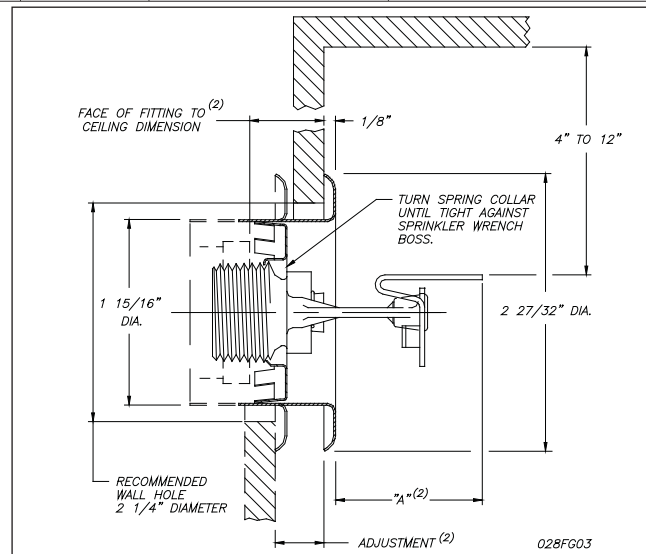

Model F1FR56 QREC HSW EC-8

Fig. 3

<sup>(2)</sup> Refer to escutcheon data table for dimensions.

# Model F1FR56 Quick Response Extended Coverage Concealed Pendent Sprinkler

**Installation Wrench:** Model RC1 Sprinkler Wrench

**Approval Type:** Quick Response Extended Coverage - Light Hazard Occupancy

## Technical Data:

Nominal Orifice	Thread Size	"K" Factor		Approval Organizations	Sprinkler Identification Number (SIN)
		US	Metric		
1/2" (15mm)	1/2" (R1/2)	5.6	80	1	RA2845

Thread Size	Model	Temp. Rating		Max. Ceiling Temp.	Bulb Color
		Sprinkler	Cover		
1/2" NPT (R1/2)	F1FR	135°F	135°F	100°F	Orange
	QREC	57°C	57°C	38°C	
1/2" NPT (R1/2)	F1FR	155°F	135°C	100°F	Red
	QREC	68°C	57°C	38°C	

Coverage Area		
Flow Rate	Pressure psi (bar)	Max. Enclosure Area Width x Length ft. x ft. (m x m)
gpm (L/m)	K=5.6 (80)	
26 (98.4)	21.6 (1.5)	16 x 16 (4.9 x 4.9)
33 (125.0)	34.7 (2.4)	18 x 18 (5.5 x 5.5)
40 (151.4)	51.0 (3.5)	20 x 20 <sup>(1)</sup> (6.0 x 6.0) <sup>(1)</sup>

<sup>(1)</sup> 135°F (57°C) Only

**Note:** 1 bar = 100 kPa

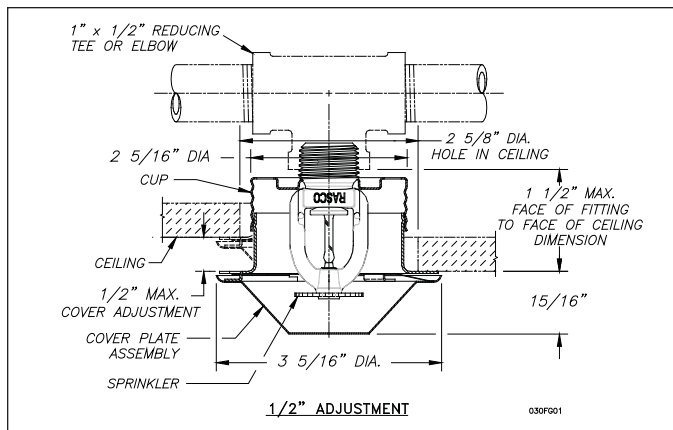

Fig. 4

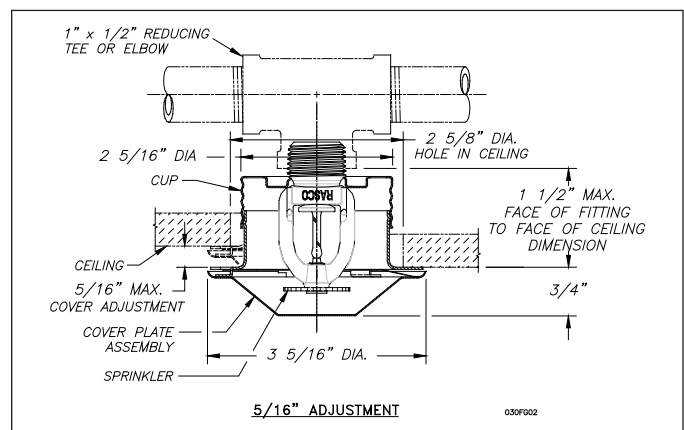

Fig. 5

## Installation Aid:

A protective cap is included for use during installation.

## Installation

Quick response sprinklers are intended for installation as specified in NFPA 13. Quick response sprinklers and standard response sprinklers should not be intermixed.

The Model F1FR56 Recessed QREC Sprinklers are to be installed as shown. The Model F1 or F2 Escutcheons illustrated are the only recessed escutcheons to be used with the Model F1FR56 EC Sprinklers. The use of any other recessed escutcheon will void all approvals and negate all warranties.

When installing Model F1FR56 QREC Sprinklers, use the Model D Sprinkler Wrench. When installing Model F1FR QREC Recessed Pendent or Sidewall Sprinklers, use the Model GFR2 Sprinkler Wrench. Any other type of wrench may damage these sprinklers.

Model F1FR56 QREC Concealed Sprinklers use 135°F (57°C) or 155°F (68°C) Model F1FR QREC Pendent Sprinklers with a threaded Model CCP cup which is factory attached to the sprinkler. The assembly is completed by the installation of the attractive, low profile, 135°F (57°C) rated cover plate assembly. The cover plate and sprinkler cup are joined using a flexible tooth threaded engagement. A choice of two cover plate assemblies provides either 1/2" (13mm) or 5/16" (8mm) of cover adjustment.

Do not install these sprinklers in ceilings which have positive pressure in the space above.

The sprinkler cup is factory attached to the Model F1FR56 QREC Sprinkler. A Teflon\*-based thread sealant should be applied to the sprinkler threads only.

\* DuPont Registered Trademark.

After a 2<sup>5</sup>/<sub>8</sub> (67mm) inch diameter hole is cut in the ceiling, the sprinkler is easily installed with the Model RC1 Wrench. When installing a sprinkler, the protective cap is removed and the wrench is positioned into the sprinkler/cup assembly until the two wrench faces engage the wrenching flats on the Model F1FR56 QREC Sprinkler. The sprinkler is then tightened into the pipe fitting. When inserting or removing the wrench from the sprinkler/cup assembly, care should be taken to prevent damage to the sprinkler. DO NOT WRENCH ON ANY OTHER PART OF THE SPRINKLER. The cover plate assembly is then pressed into the cup. Final adjustment is made by turning the cover plate until the skirt flange makes full contact with the ceiling surface. Cover plate removal requires turning in the counter clockwise direction.

After installation, inspect all sprinklers to ensure that there is a gap between the cover plate and ceiling and that the four cup slots are open and free from any air flow impediment to the space above.

Concealed cover plate/cup assemblies are listed only for use with specific sprinklers. The use of any other concealed cover plate/cup assembly with the Model F1FR56 QREC Pendent Sprinkler or the use of the Model CCP concealed cover plate assembly on any sprinkler with which it is not specifically listed may prevent good fire protection and will void all guarantees, warranties, listings and approvals.

Glass bulb sprinklers have orange bulb protectors to minimize bulb damage during shipping, handling and installation. REMOVE THIS PROTECTION AT THE TIME THE SPRINKLER SYSTEM IS PLACED IN SERVICE FOR FIRE PROTECTION. Removal of the protectors before this time may leave the bulb vulnerable to damage. RASCO wrenches are designed to install sprinklers when covers are in place. REMOVE PROTECTORS BY UNDOING THE CLASP BY HAND. DO NOT USE TOOLS TO REMOVE THE PROTECTORS.

## Maintenance

The Models F1FR56 QREC and F1FR56 QREC Recessed Sprinklers should be inspected quarterly and the sprinkler system maintained in accordance with NFPA 25. Do not clean sprinklers with soap and water, ammonia or any other cleaning fluids. Remove dust by using a soft brush or gentle vacuuming. Remove any sprinkler which has been painted (other than factory applied) or damaged in any way. A stock of spare sprinklers should be maintained to allow quick replacement of damaged or operated sprinklers. Prior to installation, sprinklers should be maintained in the original cartons and packaging until used to minimize the potential for damage to sprinklers that would cause improper operation or non-operation.

## Escutcheon Data:

Escutcheon Model	Adjustment	"A" Dimension	Face of Fitting to Ceiling Wall Dimension
F1	Max Recessed	1 1/2" (38.1mm) <sup>(1)</sup>	3/16" - 15/16"
	Min Recessed	3/4" (19.1mm) <sup>(2)</sup>	(5m - 24mm)
F2	Max Recessed	1 1/2" (38.1mm) <sup>(1)</sup>	3/16" - 1 1/16"
	Min Recessed	1" (25mm) <sup>(2)</sup>	(5m - 17mm)
FP Push-on/Thread-off	Max Recessed	7/16" (11mm)	1 1/2" (38.1mm)
	Min Recessed	15/16" (24mm)	1" (25mm)

<sup>(1)</sup> EC Pendent.

<sup>(2)</sup> EC HSW.

## Temperature Rating

Classification	Sprinkler Temperature		Maximum Ambient Temperature		Bulb Color
	°F	°C	°F	°C	
Ordinary	135	57	100	38	Orange
Ordinary	155	68	100	38	Red

## Maximum Working Pressure

175 psi (12 bar)

100% Factory tested hydrostatically to 500 psi (34.5 bar)

## Finishes <sup>(1)</sup>

Standard Finishes		
Sprinkler <sup>(2)</sup>	Escutcheon	Coverplate
Bronze	Brass	Chrome
Chrome Plated	Chrome Plated	White
White & Black Polyester Coated	White Painted	
Special Application Finishes		
Sprinkler <sup>(2)</sup>	Escutcheon	Coverplate
Bright Brass	Bright Brass	Bright Brass
Black Plating	Black Plating	Black Plating
Black Paint	Black Paint	Black Paint
Off White	Off White	Off White
Satin Chrome	Satin Chrome	Off White

<sup>(1)</sup> Other colors and finishes are available on special order. Consult factory for details.

<sup>(2)</sup> FM Approvals limited to Bronze, Bright Brass, Satin Chrome Plated, Black Plated and Polyester Coated.

**Note:** Paint or any other coating applied over the factory finish will void approvals and warranties.

## Ordering Information

Specify:

1. Sprinkler Model
2. Sprinkler Type
3. Orifice Size
4. Deflector Type
5. Temperature Rating
6. Sprinkler Finish
7. Escutcheon Finish (where applicable)
8. Coverplate Finish (where applicable)
9. Coverplate Finish (where applicable)
10. Coverplate Adjustment
11. Coverplate Thread Size
12. Coverplate Temperature Rating

**Note:** When Model F1FR56 QREC Recessed sprinklers are ordered, the sprinklers, escutcheons and coverplates are packaged separately.

# Reliable...For Complete Protection

Reliable offers a wide selection of sprinkler components. Following are some of the many precision-made Reliable products that guard life and property from fire around the clock.

- Automatic sprinklers
- Flush automatic sprinklers
- Recessed automatic sprinklers
- Concealed automatic sprinklers
- Adjustable automatic sprinklers
- Dry automatic sprinklers
- Intermediate level sprinklers
- Open sprinklers
- Spray nozzles
- Alarm valves
- Retarding chambers
- Dry pipe valves
- Accelerators for dry pipe valves
- Mechanical sprinkler alarms
- Electrical sprinkler alarm switches
- Water flow detectors
- Deluge valves
- Detector check valves
- Check valves
- Electrical system
- Sprinkler emergency cabinets
- Sprinkler wrenches
- Sprinkler escutcheons and guards
- Inspectors test connections
- Sight drains
- Ball drips and drum drips
- Control valve seals
- Air maintenance devices
- Air compressors
- Pressure gauges/identification signs
- Fire department connection

---

The equipment presented in this bulletin is to be installed in accordance with the latest published Standards of the National Fire Protection Association, Factory Mutual Research Corporation, or other similar organizations and also with the provisions of governmental codes or ordinances whenever applicable. Products manufactured and distributed by Reliable have been protecting life and property for over 90 years, and are installed and serviced by the most highly qualified and reputable sprinkler contractors located throughout the United States, Canada and foreign countries.

Manufactured by

**Reliable**<sup>®</sup>

The Reliable Automatic Sprinkler Co., Inc.  
(800) 431-1588 Sales Offices  
(800) 848-6051 Sales Fax  
(914) 829-2042 Corporate Offices  
[www.reliablesprinkler.com](http://www.reliablesprinkler.com) Internet Address



Revision lines indicate updated or new data.

EG. Printed in U.S.A 12/10 P/N 9999970388