



Model JL-14 (SIN RA1812) Early Suppression Fast Response Sprinkler

Product Description

The Reliable Model JL-14 Early Suppression Fast Response (ESFR) Sprinkler is intended for use against severe fire challenges. This sprinkler is designed to respond quickly to growing fires and will deliver a heavy water discharge to “suppress” rather than “control” fires.

Note: The Model JL-14 ESFR sprinkler utilizes a levered fusible alloy solder link in either a 165°F (74°C) or a 212°F (100°C) rating.

The sprinkler has a Nominal K Factor of 14.0 (metric 200) and will deliver approximately 100 gpm (397 L/min) of water at 50 psi (3,4 bar).

The deflector and frame provide a broad, very symmetrical, hemispherical pattern capable of suppressing fires between sprinklers in high storage height areas and at the same time retaining a high momentum central core to penetrate and suppress fires occurring directly beneath the sprinkler in low storage height areas.

Application and Installation

The Model JL-14 ESFR sprinkler is intended for installation in accordance with NFPA 13 (2002) and FM Loss Prevention Data Sheet 2-2 as well as the Authority Having Jurisdiction.

This sprinkler is intended for protection of palletized and solid piled and open frame single row, double row, multiple row and portable rack storage of most common materials including unexpanded and cartoned expanded plastics.

The JL-14 ESFR sprinkler was designed to be shorter, and more compact than other ESFR sprinklers. The shorter sprinkler allows piping to be installed further from the ceiling and obstructions. The JL-14 ESFR sprinkler is also less susceptible to damage due to smaller deflector and frame design. The lighter JL-14 ESFR passed rough use and abuse test in the labs without plastic protectors.

The Model JL-14 ESFR Sprinkler is FM approved [165°F (74°C) and 212°F (100°C) temperature ratings only] for use in buildings to 45 ft. (13.7m) high with storage heights to 40 ft. (12.1m) when installed in accordance with Factory Mutual Loss Prevention Data Sheet 2-2 or other FM Installation Standards.

The Model JL-14 ESFR Sprinkler is UL Listed and Certified for Canada (all ratings) for installation in accordance with NFPA Standards for storage heights to 35 ft. (10.7m) in buildings to 40 ft. (12.1m) high without in-rack sprinklers & 40 ft (12.1m) storage height in buildings 45 (13.7m) ft. high with one level of in-rack sprinklers.



Model JL-14 ESFR Sprinkler

Design Criteria

General guidelines:

Sprinkler Position: Pendent, align frame arms with the pipe. Deflectors should be parallel with the ceiling or roof.

System Type: Wet Pipe Systems Only

Maximum area of coverage: 100 ft² (9,3m²), greater coverage area are allowable in some cases.

Minimum area of coverage: 64 ft² (5,8m²)

Maximum slope ceiling: 2/12 pitch (9,5°)

Maximum spacing: 12 ft (3,7m) for building heights up to 30 ft (9,1m) and 10 feet (3,1m) for building heights greater than 30 ft (9,1m)

Minimum spacing: 8 feet (2,4m²)

Deflector distance from walls: At least 4 inches (102mm) from walls, and no more than one-half the allowable distance permitted between sprinklers.

Deflector to Top of Storage: at least 36in (914mm).

Deflector to ceiling Distance: 6-14 in (152-356mm) per NFPA 13. 5-14 in (121-35mm) per FM 2-2.

Center Line of Thermal Sensing

Element To Ceiling Distance: 4-13 in (102-330mm) per FM

Listings and Approvals

1. Listed by Underwriters Laboratories Inc. and UL certified for Canada (cULus)
2. Certified by FM Approvals

Model JL-14 Temperature Ratings and Approvals

Classification	Sprinkler Temperature		Link Color	Frame Color	Maximum Ambient Temperature		Approvals	Sprinkler Identification Number (SIN)
	°F	°C			°F	°C		
Ordinary Intermediate	165 212	74 100	Black White	Uncolored White	100 150	38 66	UL, FM UL, FM	RA1812

Installation Data

Sprinkler Type	Thread Size	"K" Factor		Maximum Working Pressure	Finish
		US	Metric		
Pendent Only	3/4" (R3/4)	14.0	200	175 psi (12,1 bar)	Bronze

Maintenance

The Model JL-14 ESFR Sprinkler should be inspected quarterly and the sprinkler system maintained in accordance with NFPA 25. Do not clean sprinkler with soap and water, ammonia or any other cleaning fluid. Remove any sprinkler that has been painted (other than factory applied) or damaged in any way. A stock of spare sprinklers should be maintained to allow quick replacement of damaged or operated sprinklers. Prior to installation, sprinklers should be maintained in the original cartons and packaging until used, to minimize the potential for damage to sprinklers that would cause improper operation or non-operation.

Once operated, automatic sprinklers cannot be reassembled and reused. New sprinklers of the same size, type and temperature rating must be installed. A cabinet of replacement sprinklers should be provided for this purpose.

Model JL-14 ESFR Sprinkler Specification

Sprinklers shall be Early Suppression Fast Response (ESFR) pendent suppression mode sprinklers specifically tested and [UL Listed] [FM Approved] for commodity storage applications. Sprinkler frame and deflector to be of bronze construction. Fusible link assembly shall utilize the strut and lever principle of operation with approved fast response black-painted or white-painted beryllium-nickel thermal element. Water seal shall consist of a Teflon-coated Bellville spring washer and brass cap assembly containing no plastic parts. ESFR sprinklers shall have a nominal K-factor of 14.0 with 3/4" NPT threaded end connections. Sprinkler temperature rating shall be [Ordinary 165°F (74°C)] [Intermediate 212°F (100°C)]. ESFR pendent sprinklers shall be Reliable Model JL-14 (Bulletin 018).

Model J1 Sprinkler Wrench



Use only the Model J1 sprinkler wrench for removal and installation. Any other type of wrench may damage the sprinkler.

Note: Sprinklers should be tightened between 14 - 20 ft-lbs (19 - 27,1 N-m) torque. Sprinklers not tightened to recommended torque may cause leakage or impairment of the sprinklers. Damage sprinklers must be replaced immediately.

Ordering Information Specify:

1. Temperature rating
2. Thread type 3/4" NPT or ISO 7-R3/4

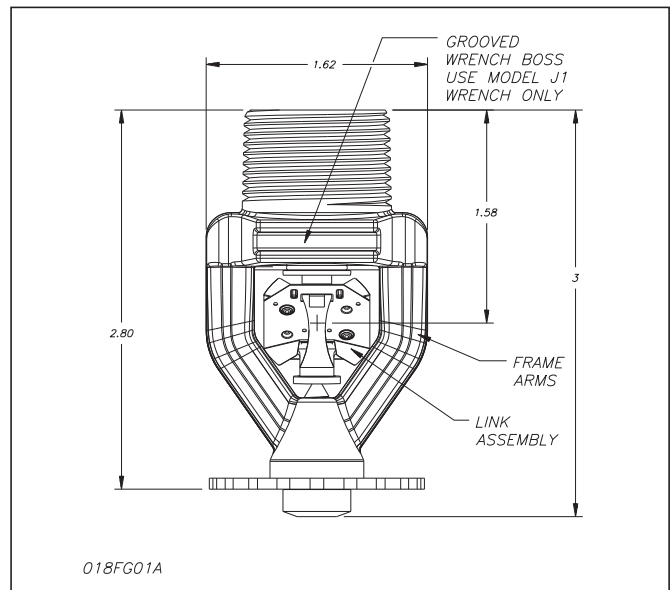

Note: Grooved sprinkler boss provided to ensure that the sprinkler wrench does not slip during installation.

The equipment presented in this bulletin is to be installed in accordance with the latest pertinent Standards of the National Fire Protection Association, Factory Mutual Research Corporation, or other similar organizations and also with the provisions of governmental codes or ordinances whenever applicable.

Products manufactured and distributed by Reliable have been protecting life and property for over 80 years, and are installed and serviced by the most highly qualified and reputable sprinkler contractors located throughout the United States, Canada and foreign countries.

Manufactured by



The Reliable Automatic Sprinkler Co., Inc.

(800) 431-1588
 (800) 848-6051
 (914) 829-2042
<http://www.reliablesprinkler.com>

Sales Offices
 Sales Fax
 Corporate Office
 Internet Address



Revision lines indicate updated or new data.
 E.G. Printed in U.S.A. 04/09 P/N 9999970378