

Reliable®

Model DH56 HSW Model DH56 HSW Recessed Model DH56 HSW Concealed Quick Response, Extended Coverage Dry Sprinklers

For coverages up to 28 feet wide and 10 feet long⁽¹⁾. 250 psi (17,2 bar) rated.

Features:

1. Coverage for long and narrow spaces such as hallways, corridors, decks and rooms up to 28 feet wide and 10 feet long.⁽¹⁾
2. Deflector to ceiling dimensions are:
4" (102mm) min. to 12" (305mm) max.
3. Minimum spacing between sprinklers 13 feet (4m).⁽¹⁾
4. Polyester Coated Corrosion Resistant Sprinklers (cULus)
5. UL Listed for extended coverage, light hazard applications.
6. 5.6 K Factor.
7. Sprinkler is approved for 250 psi (17,2 bar) applications.
8. Quick response performance.
9. ½" (13mm) adjustment of escutcheon and cover.
10. Concealed cover plate can prevent the sprinkler from being used for unintended purposes. No exposed thermal element with the concealed version.
11. Push-on/thread-off sturdy convenient escutcheon for recessed and cover for concealed.
12. Factory assembled sprinkler & cup, shipped complete with bulb protector for concealed and FP recessed versions.
13. Sprinkler & cup assembly and escutcheon or cover are separately packaged.
14. Cover finishes available in standard white paint, special bronze, black paint or flat white paint.

⁽¹⁾ See Fig. 7.

Approval Organizations

1. Listed by Underwriters Laboratories Inc. and UL certified for Canada (cULus)
2. NYC MEA 258-93-E

Products Description

The Model DH56 are quick response extended coverage sidewall dry sprinklers for use in light hazard applications. The Model DH56 dry sprinkler with SWC cover plate is a concealed sprinkler that uses Reliable's push on/thread off sidewall cover. This sprinkler has the cup factory mounted and is shipped with a bulb protector that protects the 3mm frangible glass bulb during shipping and post installation finishing operations. The DH56 can be combined in the field with the FP or F2 Escutcheon to make a recessed dry sprinkler. The SWC cover plate, FP and F2 recessed escutcheons have ½" adjustment. The SWC cover plate is attached with 135 & 165 degree solder. In the event of

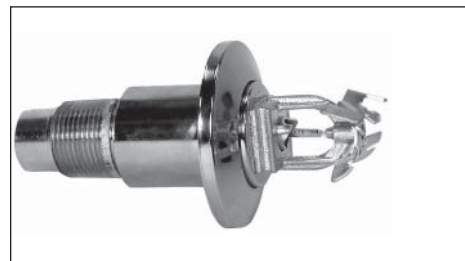

Recessed FP Pendant

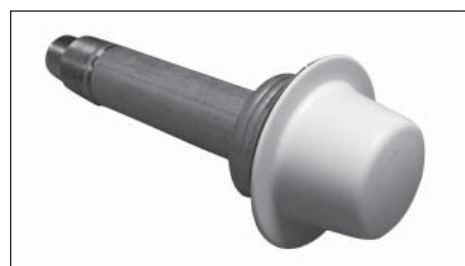

DH56 Concealed
with SWC coverplate

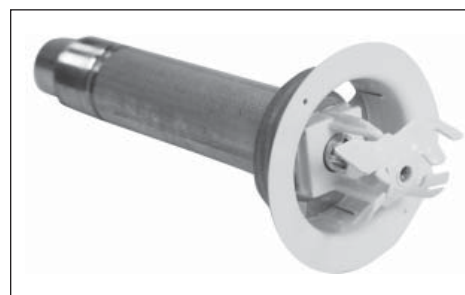

DH56 FP Recessed

a fire the rising ambient temperature melts the solder and the cover plate is ejected away by springs exposing the 3mm frangible glass bulb. The use of a 3mm bulb allows quick response which enables the sprinkler to apply water to a fire sooner than standard response sprinklers of the same temperature rating.

Model DH56 dry sprinklers are intended for use in dry and preaction systems to protect areas subjected to freezing temperatures and unheated portions inside buildings. See Fig. 1 for guidelines on using dry sprinklers in wet systems.

Environments wherein dry sprinklers are employed can be corrosive. For this reason, Model DH56 dry sprinklers have a special wax fillet placed in the gap between the cup that supports the bulb and the wrenching boss. This wax will not interfere with the operation of the sprinkler, and it prevents contaminants from entering the internal portion of the drop nipple. The wax must not be removed.

Application

The Model DH56 is a horizontal sidewall dry sprinkler intended for installation in light hazard occupancies in accordance with NFPA 13. These sprinklers are designed to provide fire protection in long and narrow spaces such as hallways, corridors, decks and rooms up to 28 feet (8,5m) wide and 10 feet (3m) long. They are rated for 250 psi (17,2 bar) and can be mounted between 4 and 12 inches (102 and 305mm) down from the ceiling.

General Installation Instructions

Model DH56 dry sprinklers must be installed only in standard (ANSI B 16.3 class 150 and ANSI B 16.4 class 125) pipe tees in the horizontal position, even at branch line ends. They should not be installed into elbows or pipe couplings located on drop nipples to the sprinklers. For these and other fittings including CPVC*, the dry sprinkler should be installed into a fitting to allow protrusion into the fitting in accordance with the diagrams. The "A" dimension of the dry sprinkler, which extends into a freezing zone from wet pipe systems, should be selected to provide, as a minimum, the specified lengths in inches shown in Fig. 1.

* Spears CPVC sprinkler adapter tees (with brass thread insert) can only be used with horizontal sidewall sprinklers which do not require protrusion into tees to prevent ice or debris blockage of sprinkler inlets. These CPVC tees do not permit sufficient sprinkler inlet protrusion as required for pendent installation.

DH56 HSW

To install the DH56 HSW dry sprinkler cut a 2¹/₈" diameter hole in the wall as shown in Fig. 4. Use the Model G3 installation wrench (see Fig. 3) to tighten the sprinkler until it is secured in the sprinkler fitting. Apply a Teflon** based sealant to the sprinkler threads before installing in the sprinkler. Wrench only on the square boss. DO NOT WRENCH ON ANY OTHER PART OF THE SPRINKLER. Installation is completed by removing the orange glass bulb-protector and assembling the slip-on escutcheon to the sprinkler's can.

DH56 HSW Recessed with FP Escutcheon

To install the DH56 HSW dry sprinkler with the FP Escutcheon as a recessed sprinkler cut a 2⁵/₈" diameter hole in the wall as shown in Fig. 5. Temporarily remove the plastic protective cap, and then use the Model XLO2 wrench (see Fig. 2) to tighten the sprinkler until it is secured in the sprinkler fitting. **Note:** The Model XLO2 wrench has a notch in it to accommodate the deflector top. This wrench can only be inserted one way. Care must be taken not to damage the deflector during tightening. Apply a Teflon** based sealant to the sprinkler threads before installing in the sprinkler. Wrench only on the square boss. DO NOT WRENCH ON ANY OTHER PART OF THE SPRINKLER. It is recommended that the sprinkler be protected during plastering and painting operations by reinstalling the plastic protective cap. Installation is completed by removing the protective cap and inserting the push-on escutcheon. Turn clockwise to adjust the escutcheon against the wall.

DH56 HSW Concealed with SWC Cover Plate

To install the DH56 HSW dry sprinkler with the SWC coverplate as a concealed sprinkler, cut a 2¹/₈" diameter hole into the wall as shown in Fig. 6. Temporarily remove the plastic protective cap, and then use the Model XLO2 wrench (see Fig. 2) to tighten the sprinkler until it is secured in the sprinkler fitting. **Note:** The Model XLO2 wrench has a notch in it to accommodate the deflector top. This wrench can only be inserted one way. Care must be taken not to damage the deflector during tightening. Apply a Teflon** based sealant to the sprinkler threads before installing in the sprinkler. Wrench only on the square boss. DO NOT WRENCH ON ANY OTHER PART OF THE SPRINKLER. It is recommended that the sprinkler be protected during plastering and painting operations by reinstalling the plastic protective cap. Installation is completed by removing the protective cap and inserting the coverplate. Coverplate assemblies provide 1/2" (13mm) of adjustment. Final adjustment is made by turning the coverplate clockwise until the skirt flange makes full contact with the wall surface. Cover removal requires turning in the counter-clockwise direction.

Concealed coverplate assemblies are listed only for use with specific sprinklers. The use of any other concealed wall sprinkler or the use of the SWC coverplate on any sprinkler with which it is not specifically listed will void all guarantees, warranties, listings and approvals.

Note: DH56 and DH56 Recessed Sprinklers have orange bulb protectors to minimize bulb damage during shipping, handling, and installation. REMOVE THIS PROTECTION AT THE TIME THE SPRINKLER SYSTEM IS PLACED IN SERVICE FOR FIRE PROTECTION. Removal of the protectors before this time may leave the bulb vulnerable to damage. RASCO wrenches are designed to install sprinklers when covers are in place. REMOVE PROTECTORS BY UNDOING THE CLASP BY HAND. DO NOT USE TOOLS TO REMOVE THE PROTECTORS.

**DuPont Registered Trademark

RECOMMENDED MINIMUM EXPOSED BARREL LENGTH BASED ON AMBIENT TEMPERATURE IN THE PROTECTED AREA
(STANDARD DH56 HSW DRY SPRINKLER SHOWN)

AMBIENT TEMPERATURE OF PROTECTED AREA* AT THE DISCHARGE END OF THE SPRINKLER	EXPOSED BARREL AMBIENT TEMPERATURE		
	40°F/4°C	50°F/10°C	60°F/16°C
	EXPOSED MINIMUM BARREL LENGTH** (FACE OF TEE TO TOP OF CEILING)		
	IN. (MM)	IN. (MM)	IN. (MM)
40°F (4°C)	0	0	0
30°F (-1°C)	0	0	0
20°F (-7°C)	4 (101)	0	0
10°F (-12°C)	8 (203)	1 (25.1)	0
0°F (-18°C)	12 (305)	3 (75)	0
-10°F (-23°C)	14 (356)	4 (101)	1 (25.1)
-20°F (-29°C)	14 (356)	6 (152)	3 (75)
-30°F (-34°C)	16 (406)	8 (203)	4 (101)
-40°F (-40°C)	18 (457)	8 (203)	4 (101)
-50°F (-46°C)	20 (508)	10 (254)	6 (152)
-60°F (-51°C)	20 (508)	10 (254)	6 (152)

* THE PROTECTED AREA REFERS TO THE AREA BELOW THE CEILING. THE AMBIENT TEMPERATURE IS THE TEMPERATURE AT THE DISCHARGE END OF THE SPRINKLER. FOR PROTECTED AREA TEMPERATURES THAT OCCUR BETWEEN THE VALUES LISTED, USE THE NEXT COOLER TEMPERATURE.

**THE MIN. REQUIRED BARREL LENGTH IS NOT THE SAME AS THE 'A' DIMENSION. NOTE: EXPOSED MINIMUM BARREL LENGTHS ARE INCLUSIVE UP TO 30MPH WIND VELOCITIES IN THE PROTECTED AREA.

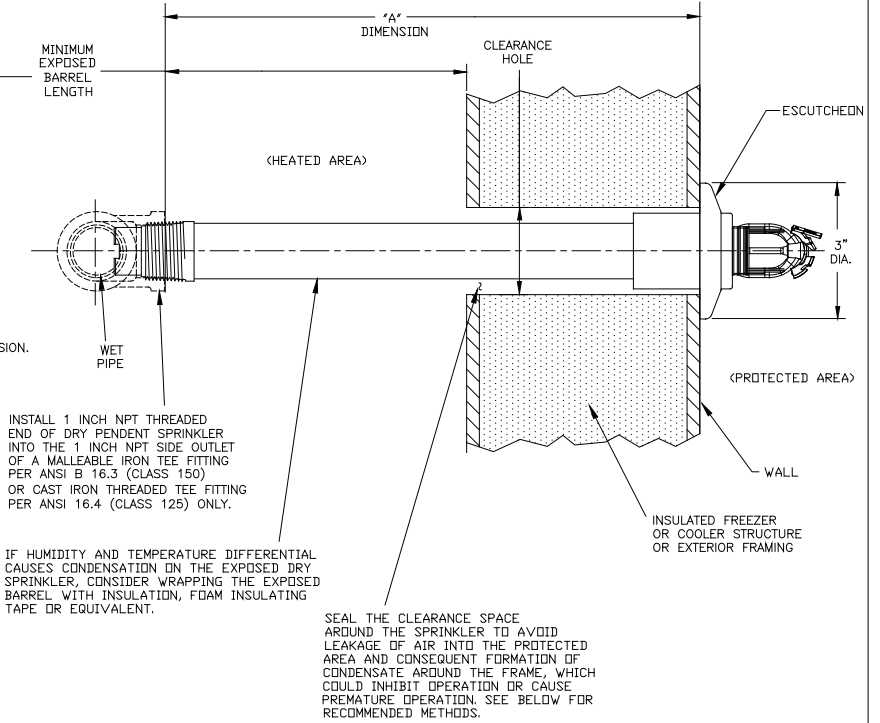

INSTALL 1 INCH NPT THREADED END OF DRY PENDENT SPRINKLER INTO THE 1 INCH NPT SIDE OUTLET OF A MALLEABLE IRON TEE FITTING PER ANSI B 16.3 (CLASS 150) OR CAST IRON THREADED TEE FITTING PER ANSI 16.4 (CLASS 125) ONLY.

IF HUMIDITY AND TEMPERATURE DIFFERENTIAL CAUSES CONDENSATION ON THE EXPOSED DRY SPRINKLER, CONSIDER WRAPPING THE EXPOSED BARREL WITH INSULATION, FOAM INSULATING TAPE OR EQUIVALENT.

SEAL THE CLEARANCE SPACE AROUND THE SPRINKLER TO AVOID LEAKAGE OF AIR INTO THE PROTECTED AREA AND CONSEQUENT FORMATION OF CONDENSATE AROUND THE FRAME, WHICH COULD INHIBIT OPERATION OR CAUSE PREMATURE OPERATION. SEE BELOW FOR RECOMMENDED METHODS.

RECOMMENDED DRY SPRINKLER SEAL ARRANGEMENTS
(STANDARD DH56 HSW DRY SPRINKLER SHOWN)

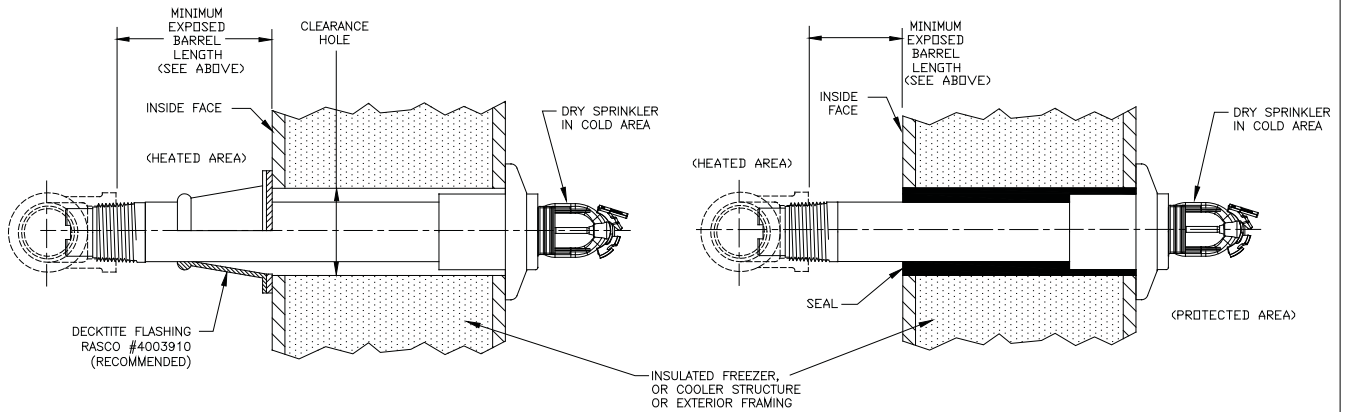

016FG05A

Fig. 1

Technical Data:

K Factor		Thread Size	Temperature Rating		Maximum Ambient Temperature	Sprinkler Identification Number (SIN)
US	Metric		Sprinkler	SWC Cover		
5.6	80	1"	155°F (68°C)	135°F (57°C)	100°F (38°C)	RA1664
			175°F (79°C)	165°F (74°C)	150°F (66°C)	
			200°F (93°C)	165°F (74°C)	150°F (66°C)	

Coverage Area		
Maximum Coverage Area Width x Length ft x ft (m x m)	Flow Rate gpm (L/min)	Pressure psi (bar)
28 x 8 (8,5 x 2,4)	23 (87,1)	16.9 (1,2)
28 x 10 (8,5 x 3)	28 (106)	25 (1,7)

Approval Type:

- Quick Response, Extended Coverage.
- Approved for installation in accordance with NFPA 13 for light hazard occupancies.

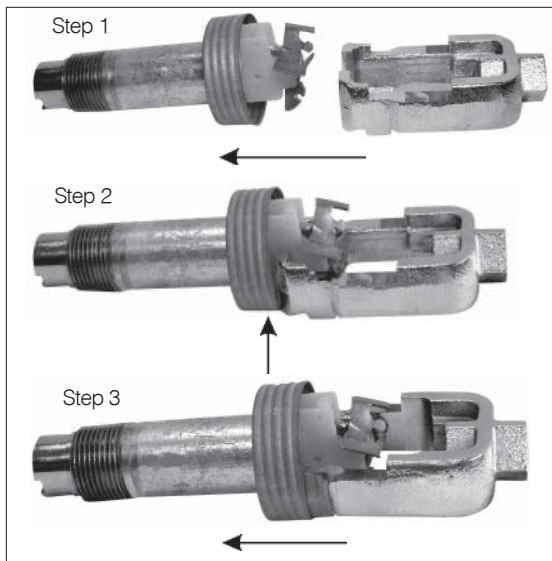

Fig. 2 - XLO2 Wrench

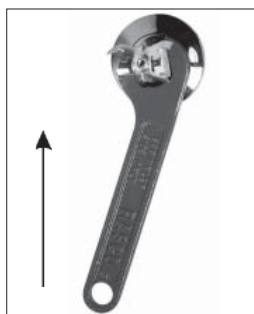

Fig. 3 - G3 Wrench

Maintenance

Model DH56 Quick Response Dry Sprinklers should be inspected quarterly and the sprinkler system maintained in accordance with NFPA 25. Do not remove the factory applied thermally sensitive wax fillet between the bulb supporting cup and the wrenching boss. Do not replace this wax with a substitute substance. An alternate substance may interfere with proper operation of the sprinkler. Do not clean sprinklers with soap and water, ammonia or any other cleaning fluids. Remove dust by using a soft brush or gentle vacuuming. Remove any sprinkler which has been painted (other than factory applied) or damaged in any way. A stock of spare sprinklers should be maintained to allow quick replacement of damaged or operated sprinklers. Prior to installation, sprinklers should be maintained in their original cartons and packaging until used to minimize the potential for damage to sprinklers that would cause improper operation or non-operation.

Model DH56 Quick Response Extended Coverage Horizontal Sidewall Dry Sprinkler Specification

Sprinklers shall be a [quick response – cULus Listed] extended coverage horizontal sidewall sprinkler for light hazard occupancies. Sprinklers to be of bronze frame construction with a special deflector capable of providing a discharge over a coverage area of 28 ft. (8,5m) wide, and 10 ft. (3m) long horizontal throw. Water seal assembly shall consist of a Teflon-coated Belleville spring washer. Installation shall permit sprinkler deflectors to be positioned 4" (102mm) to 12" (305mm) below the ceiling. Sprinklers shall have a nominal K-factor of 5.6 (80), and 1" NPT thread. Sprinkler temperature rating shall be [155°F (68°C)] and [200°F (93°C)]. Rated working pressure shall be 250 psi (17.2 bar). Standard finish: [white][chrome][bronze][Special finish– specify]. Quick response extended coverage horizontal sidewall dry sprinklers shall be Reliable Model DH56, SIN RA1664 (Bulletin 016).

For recessed EC horizontal sidewall sprinklers: Replace "horizontal sidewall" with "recessed horizontal sidewall." Add: (1) Recessed escutcheon assembly shall be a two-piece escutcheon of push-on and thread off design with 1/2" (13mm) adjustment. Standard finish shall be chrome, white and brass. Quick response recessed horizontal sidewall sprinklers shall be Reliable Model DH56, SIN RA1664 (Bulletin 016).

For concealed EC horizontal sidewall sprinklers: Replace "horizontal sidewall" with "concealed horizontal sidewall." Add: Cover plate assembly shall consist of a brass cover plate and copper alloy retainer flange. Method of attaching the cover plate to the sprinkler cup shall be a push-on and thread-off design allowing a 1/2" (13mm) cover plate adjustment. Cover plate temperature rating shall be 135°F (57°C) for 155°F (68°C) dry sprinkler and 165°F (74°C) for 200°F (93°C) dry sprinkler. A bulb protector shall be provided and factory installed inside the sprinkler cup to protect the glass bulb from damage, which could occur during construction before the cover plate is installed. Standard cover plate finish: [white] [Custom Color– specify]. Quick response extended coverage concealed horizontal sidewall dry sprinklers shall be Reliable Model DH56, SIN RA1664 (Bulletin 016).

DH56 HSW DRY SPRINKLER

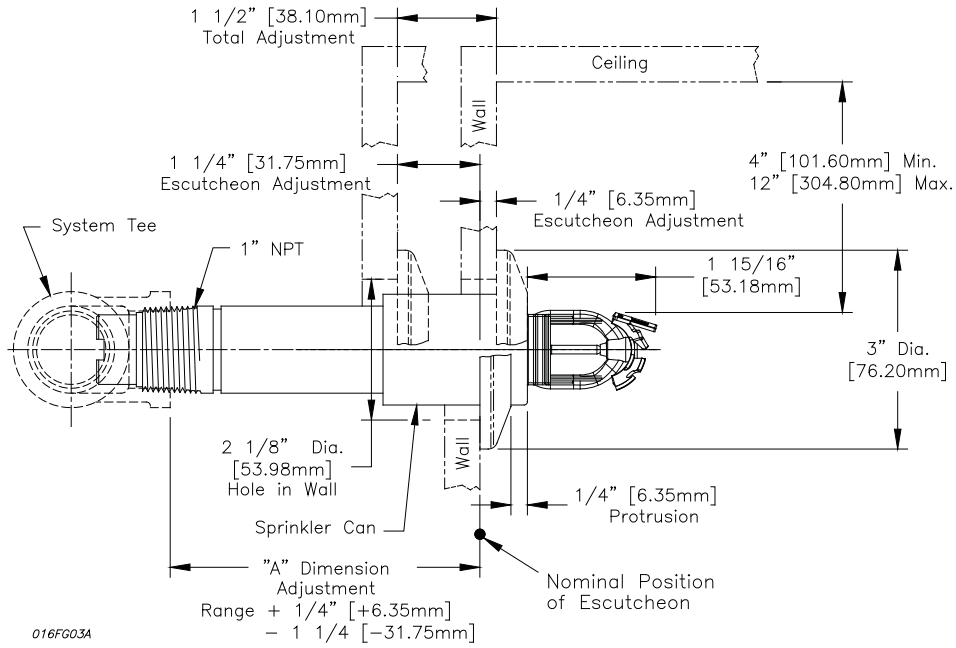

Available "A" Dim. is 2" to 48" (51mm to 1219mm) in 1/4" (6mm) increments

Note: The Sprinkler Can protrudes 1/4" when escutcheon is in nominal position. Escutcheon adjustment provides + 1/4" (+6mm) to -1/4" (-32mm) "A" dimension adjustment range.

Fig. 4

DH56 HSW RECESSED DRY SPRINKLER

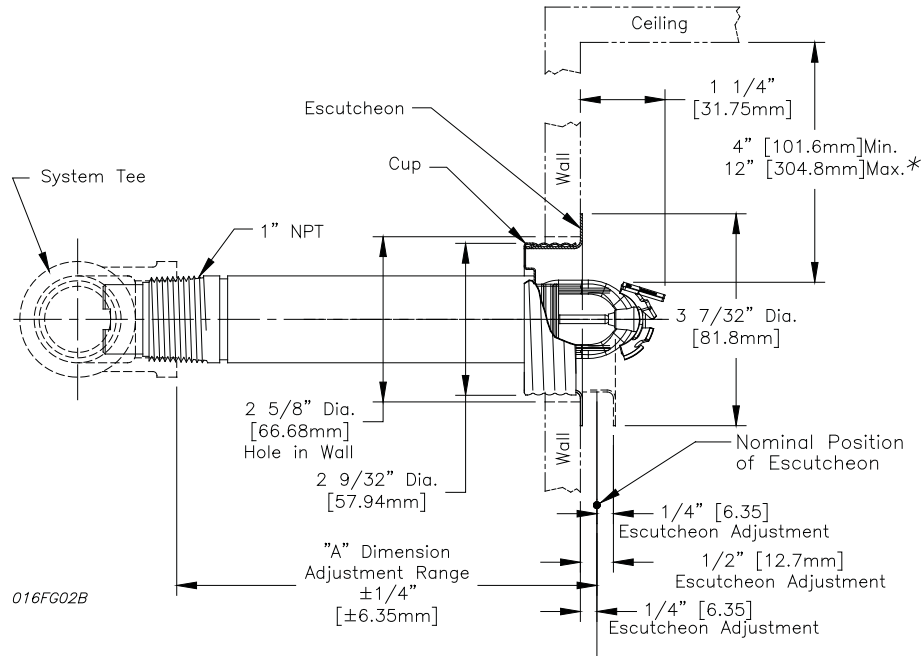

Available "A" Dim. is 3-1/2" to 48" (89mm to 1219mm) in 1/4" (6mm) increments

Note: Do not install the Model DH56 Dry EC Horizontal Recessed Sidewall Sprinkler in walls which have positive pressure in their side space.

Fig. 5

DH56 HSW CONCEALED DRY SPRINKLER

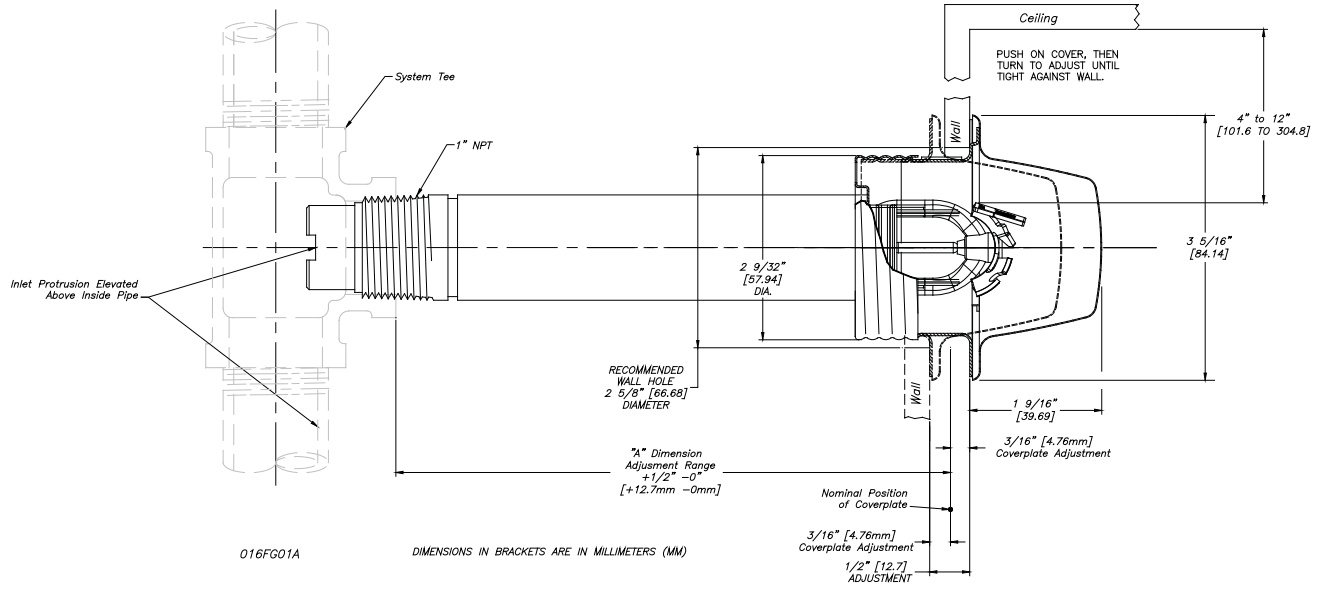

Available "A" Dim. is 3-1/2" to 48" (89mm to 1219mm) in 1/4" (6mm) increments

Fig. 6

Ordering Information

Specify:

- Sprinkler Type (select one):
 - Model DH56 Dry EC HSW
 - Model DH56 Dry Recessed EC HSW/FP
 - Model DH56 Dry Concealed EC HSW
- Sprinkler Temperature Rating.
- Sprinkler Finish.
- Cover Plate/Escutcheon Finish.
- Length: "A" Dimension (face of tee to face of ceiling or wall) in 1/4" (6mm) increments.

Note:

- The "A" dimension is based on a nominally gauged pipe thread "make-up" of 0.600" (15mm) per ANSI B2.1 [7½ threads approximately].
- All platings and paintings are decorative and intended for interior use.

UL Listing Category

Sprinklers, Automatic and Open.
Quick Response Sprinklers.

Installation Wrench

Model XLO2 Sprinkler Wrench (Recessed & Concealed)
Model G3 Sprinkler Wrench

Note: A leak tight 1" NPT sprinkler joint can be obtained with a torque of 20-30 ft-lbs (27.1 - 40.7 N-m). Do not tighten sprinklers over maximum recommended torque. It may cause leakage or impairment of the sprinklers.

Escutcheon Data:

FP cup/escutcheon assembly - ½" (13mm) adjustment

Finishes ⁽¹⁾

Standard Finishes ⁽¹⁾		
Sprinkler	Escutcheon	Cover Plate
White Polyester ⁽²⁾ /Chrome/ Bronze	White/Chrome	White

⁽¹⁾ Other colors and finishes are available. Consult factory for details.

⁽²⁾ cULus Corrosion Resistant Sprinklers.

⁽³⁾ White painted sprinklers will have chrome plated can.

Note: Paint or any other coatings applied over the factory finish will void all approvals and warranties.

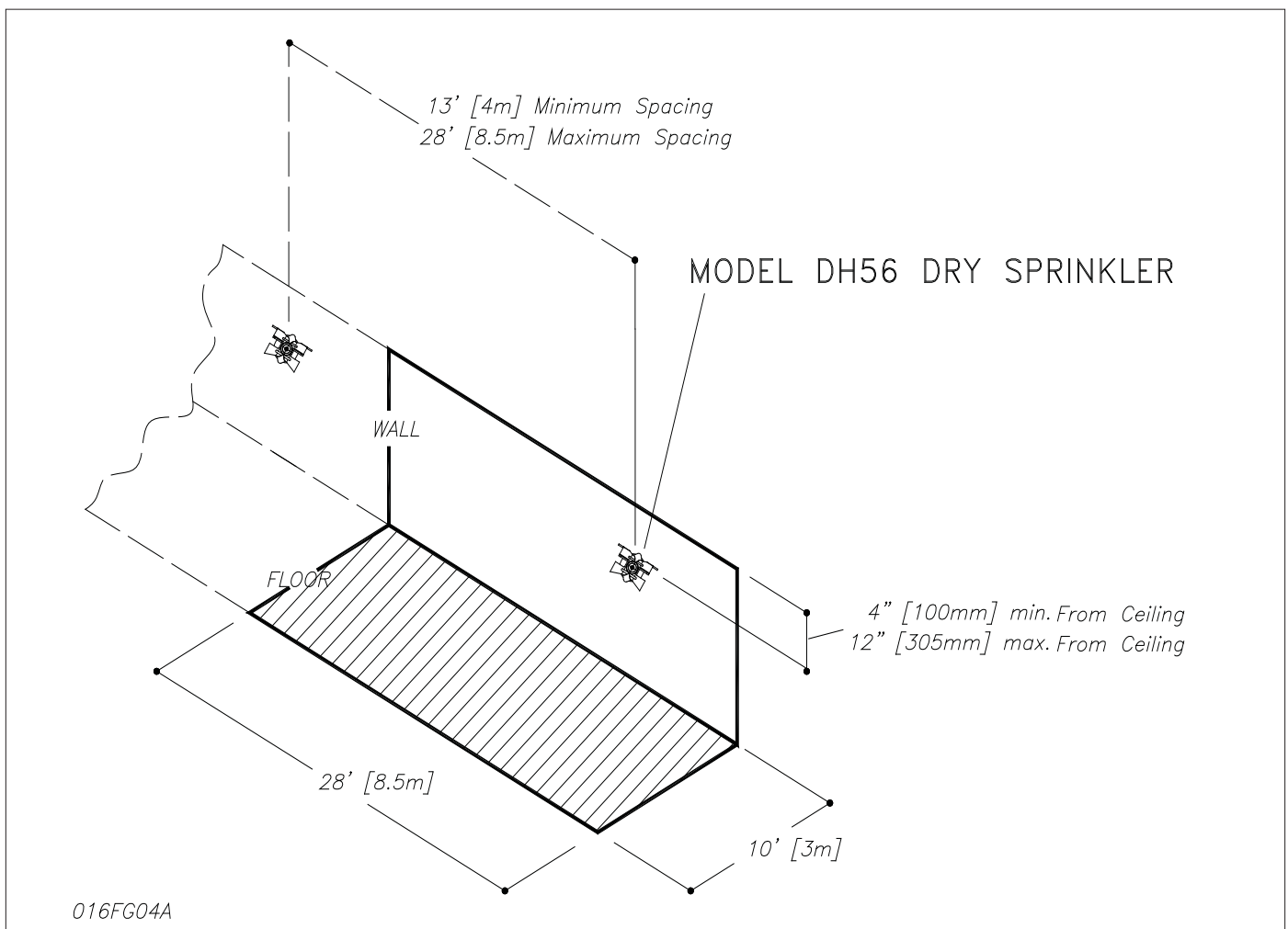

Fig. 7

Reliable...For Complete Protection

Reliable offers a wide selection of sprinkler components. Following are some of the many precision-made Reliable products that guard life and property from fire around the clock.

- Automatic sprinklers
- Flush automatic sprinklers
- Recessed automatic sprinklers
- Concealed automatic sprinklers
- Adjustable automatic sprinklers
- Dry automatic sprinklers
- Intermediate level sprinklers
- Open sprinklers
- Spray nozzles
- Alarm valves
- Retarding chambers
- Dry pipe valves
- Accelerators for dry pipe valves
- Mechanical sprinkler alarms
- Electrical sprinkler alarm switches
- Water flow detectors
- Deluge valves
- Detector check valves
- Check valves
- Electrical system
- Sprinkler emergency cabinets
- Sprinkler wrenches
- Sprinkler escutcheons and guards
- Inspectors test connections
- Sight drains
- Ball drips and drum drips
- Control valve seals
- Air maintenance devices
- Air compressors
- Pressure gauges/identification signs
- Fire department connection

The equipment presented in this bulletin is to be installed in accordance with the latest published Standards of the National Fire Protection Association, Factory Mutual Research Corporation, or other similar organizations and also with the provisions of governmental codes or ordinances whenever applicable. Products manufactured and distributed by Reliable have been protecting life and property for over 90 years, and are installed and serviced by the most highly qualified and reputable sprinkler contractors located throughout the United States, Canada and foreign countries.

Manufactured by

Reliable[®]

The Reliable Automatic Sprinkler Co., Inc.

(800) 431-1588

(800) 848-6051

(914) 829-2042

www.reliablesprinkler.com

Sales Offices

Sales Fax

Corporate Offices

Internet Address



Recycled
Paper

Revision lines indicate updated or new data.

EG. Printed in U.S.A 03/10

P/N 9999970308