



Model F1FR Series Quick Response Standard Spray

Model F1FR 56 Sprinkler Types

Standard Upright
Standard Pendent
Conventional

Model F1FR 56 Recessed Sprinkler Types

Standard Pendent/F1/F2/FP

Model F1FR 56 Concealed Sprinkler Types

Standard Pendent

Listing & Approvals

1. Underwriters Laboratories Inc. and Certified for Canada (cULus).
2. Factory Mutual Approvals (FM)
 - Light Hazard - No Limitations
 - Ordinary Hazard - Group 1 & 2, wet systems only.
3. Loss Prevention Council (LPCB, UK)
4. VdS Schadenverhütung GmbH

UL Listing Category

Sprinklers, Automatic & Open (VNIV)
Quick Response Sprinkler

Product Description

Reliable Models F1FR Series Sprinklers are quick response sprinklers which combine the durability of a standard sprinkler with the attractive low profile of a decorative sprinkler.

The Models F1FR Series Recessed automatic sprinklers utilize a 3.0 mm frangible glass bulb. These sprinklers have demonstrated response times in laboratory tests which are five to ten times faster than standard response sprinklers. This quick response enables the Model F1FR Series sprinklers to apply water to a fire much faster than standard sprinklers of the same temperature rating.

The glass bulb consists of an accurately controlled amount of special fluid hermetically sealed inside a precisely manufactured glass capsule. This glass bulb is specially constructed to provide fast thermal response. The balance of parts are made of brass, copper and beryllium nickel.

At normal temperatures, the glass bulb contains the fluid in both the liquid and vapor phases. The vapor phase can be seen as a small bubble. As heat is applied, the liquid expands, forcing the bubble smaller and smaller as the liquid pressure increases. Continued heating forces the liquid to push out against the bulb, causing the glass to shatter, opening the waterway and allowing the deflector to distribute the discharging water.



Upright



Pendent



Conventional



Recessed
Pendent/F1/F2

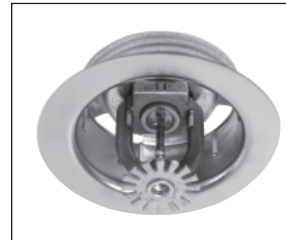

Recessed
Pendent/FP



Concealed Pendent

Application

Quick response sprinklers are used in fixed fire protection systems: Wet, Dry, Deluge or Preaction. Care must be exercised that the orifice size, temperature rating, deflector style and sprinkler type are in accordance with the latest published standards of the National Fire Protection Association or the approving Authority Having Jurisdiction. Quick response sprinklers are intended for installation as specified in NFPA 13. Quick response sprinklers and standard response sprinklers should not be intermixed.

Model F1FR Quick Response Upright, Pendent & Conventional Sprinklers

Installation Wrench: Model D Sprinkler Wrench

Installation Data:

Nominal Orifice	Thread Size	Nominal K Factor		Sprinkler Height	Approval Organization	Sprinkler Identification Number (SIN)	
		US	Metric			Upright	Pendent
Standard-Upright (SSU) and pendent Deflectors Marked to Indicate Position							
1/2" (15mm)	1/2" NPT(R1/2)	5.6	80	2.25" (57mm)	1, 2, 3, 4	RA1425 ⁽¹⁾	RA1414 ⁽¹⁾⁽²⁾
Conventional-Install in Upright or Pendent Position							
15mm ⁽¹⁾	1/2" NPT(R1/2)	5.6	80	57mm	3, 4	RA1475	

⁽¹⁾ cULus listed corrosion resistant (Polyester coated) sprinkler.

⁽²⁾ Polyester coated FM approved sprinkler.



Upright



Pendent



Conventional

Model F1FR 56 Quick Response Recessed Pendent Sprinkler

Installation Wrench: Model GFR2 Sprinkler Wrench

Installation Data:

Nominal Orifice	Thread Size	K Factor		Sprinkler Height	Sprinkler Identification Number (SIN)
		US	Metric		
1/2" (15mm)	1/2" NPT(R1/2)	5.6	80	2.25" (57mm)	RA1414

⁽¹⁾ Refer to escutcheon data table for approvals and dimensions.

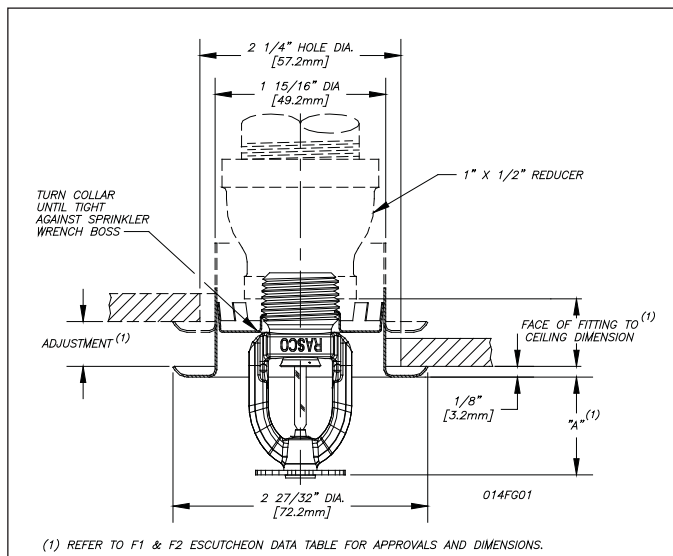

Model F1FR 56/F1 or F2

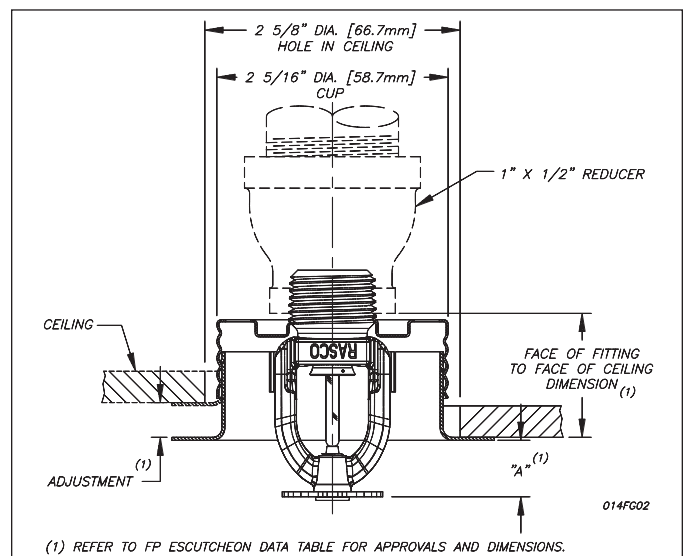

Model F1FR 56/FP

Model F1FR Quick Response Concealed Pendent Sprinklers

Installation Wrench: Model RC1 Sprinkler Wrench

Technical Data:

Nominal Orifice	"K" Factor		Thread Size	Model	Temp. Rating		Max. Ambient Temp	Bulb Color	Approvals	Sprinkler Identification Number(SIN)
	US	Metric			Sprinkler	Cover				
1/2" (15mm)	5.6	80	1/2" NPT	F1FR	135°F/57°C	135°F/57°C	100°F/38°C	Orange	1	RA1414
1/2" (15mm)	5.6	80	1/2" NPT	F1FR	155°F/68°C	135°F/57°C	100°F/38°C	Red	1, 4 ⁽¹⁾	RA1414
1/2" (15mm)	5.6	80	1/2" NPT	F1FR	175°F/79°C	165°F/74°C	100°F/38°C	Yellow	1	RA1414
1/2" (15mm)	5.6	80	1/2" NPT	F1FR	200°F/93°C	165°F/74°C	100°F/38°C	Green	1	RA1414

⁽¹⁾ For VdS only = 155°F/68°C Norbulb and 1/2" [12,7mm] adjustment.

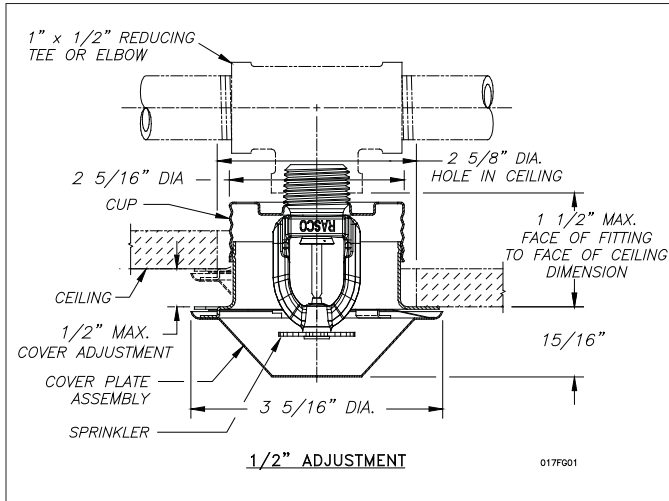

Figure 1

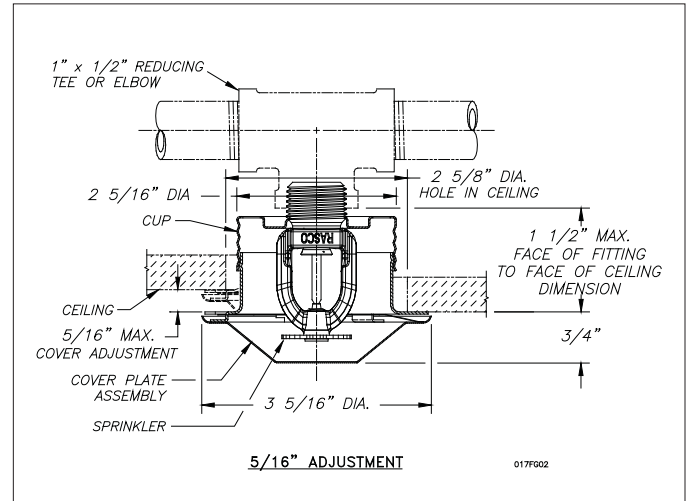

Figure 2

Installation Aid

A protective cap is included for use during installation. **Important:** The F1FR 56 Sprinkler with Model CCP cover plate is not an FM Approved combination.

Installation

Quick response sprinklers are intended for installation as specified in NFPA 13. Quick response sprinklers and standard response sprinklers should not be intermixed.

The Model F1FR 56 Recessed Quick Response Sprinklers are to be installed as shown. The Model F1 or F2 Escutcheons illustrated are the only recessed escutcheons to be used with the Model F1FR 56 Sprinklers. The use of any other recessed escutcheon will void all approvals and negate all warranties.

When installing Model F1FR 56 Sprinklers, use the Model D Sprinkler Wrench. Use the Model GFR2 Wrench for installing F1FR 56 Recessed Pendent Sprinklers. Any other type of wrench may damage these sprinklers.

NOTE: A leak tight 1/2" NPT (R1/2) sprinkler joint can be obtained with a torque of 8-18 ft-lbs (10,8 - 24,4 N-m). Do not tighten sprinklers over maximum recommended torque. It may cause leakage or impairment of the sprinklers.

The Model F1FR 56/CCP Concealed Sprinkler uses the 1/2" orifice, 1/2" NPT (R1/2), 135°F (57°C), 155°F (68°C), 175°F (79°C) or 200°F (93°C) Model F1FR 56 Pendent

Sprinkler with a threaded Model CCP cup which is factory attached to the sprinkler. The assembly is completed by the installation of the attractive, low profile, 135°F (57°C) or 165°F (74°C) rated Model CCP push on cover plate assembly. The cover plate and sprinkler cup assemblies are joined using a cover plate skirt with flexible tabs for threaded engagement. A choice of two cover plate assemblies provide either 1/2" (13mm) or 5/16" (8mm) of cover adjustment.

Do not install these sprinklers in ceiling which have positive pressure in the space above.

After a 2 5/8" (67mm) diameter hole is cut in the ceiling, the sprinkler is easily installed with the Model RC1 Wrench. A Teflon* based thread sealant should be applied to the sprinkler threads only. The Model RC1 Wrench is then used to engage the sprinkler wrenching surfaces and to install the sprinkler in the fitting. When inserting or removing the wrench from the sprinkler/cup assembly, care should be taken to prevent damage to the sprinkler. **DO NOT WRENCH ON ANY OTHER PART OF THE SPRINKLER.** The cover plate is then pushed onto the cup. Final adjustment is made by hand turning the cover plate until the skirt flange makes full contact with the ceiling. Cover plate removal requires turning in the counter clockwise direction.

After installation, inspect all sprinklers to ensure that there is a gap between the cover plate and ceiling and that the four cup slots are open and free from any air flow impediment to the space above.

Concealed cover plate/cup assemblies are listed only for use with specific sprinklers. The use of any other concealed cover plate/cup assembly with the Model F1FR 56 Pendent Sprinkler or the use of the Model CCP Concealed cover plate assembly on any sprinkler with which it is not specifically listed may prevent good fire protection and will void all guarantees, warranties, listings and approvals.

Glass bulb sprinklers have orange bulb protectors to minimize bulb damage during shipping, handling and installation. REMOVE THIS PROTECTION AT THE TIME THE SPRINKLER SYSTEM IS PLACED IN SERVICE FOR FIRE PROTECTION. Removal of the protectors before this time may leave the bulb vulnerable to damage. RASCO wrenches are designed to install sprinklers when covers are in place. REMOVE PROTECTORS BY UNDOING THE CLASP BY HAND. DO NOT USE TOOLS TO REMOVE THE PROTECTORS.

Temperature Ratings

Classification	Sprinkler Temperature		Max. Ambient Temp.	Bulb Color
	°C	°F		
Ordinary	57	135	100°F (38°C)	Orange
Ordinary	68	155	100°F (38°C)	Red
Intermediate	79	175	150°F (66°C)	Yellow
Intermediate	93	200	150°F (66°C)	Green
High ⁽¹⁾	141	286	225°F (107°C)	Blue

⁽¹⁾ Not available for recessed sprinklers.

Escutcheon Data

Escutcheon Model	Approvals	Adjustment	"A" Dimension	Face of Fitting to Ceiling or Wall Dimension
F1	1, 3, 4	Max Recess Min Recess	1 1/2" (38.1mm) 3/4" (19.1mm)	3/16" - 15/16" (5mm - 24mm)
F2	1, 2, 3, 4,	Max Recess Min Recess	1 1/2" (38.1mm) 1" (25mm)	3/16" - 11/16" (5mm - 17mm)
FP Push-on/ Thread-off	1, 4	Max Recessed Min Recessed	7/16" (11mm) 15/16" (24mm)	1 1/2" (38.1mm) 1" (25.4mm)

Maintenance

The Models F1FR 56 and F1FR 56 Recessed Sprinklers should be inspected quarterly and the sprinkler system maintained in accordance with NFPA 25. Do not clean sprinklers with soap and water, ammonia or any other cleaning fluids. Remove dust by using a soft brush or gentle vacuuming. Remove any sprinkler which has been painted (other than factory applied) or damaged in any way. A stock of spare sprinklers should be maintained to allow quick replacement of damaged or operated sprinklers. Prior to

installation, sprinklers should be maintained in the original cartons and packaging to minimize the potential for damage to sprinklers that would cause improper operation or non-operation.

Sprinkler Types

Standard Upright
Standard Pendent
Conventional
Recessed Pendent

Finishes ⁽¹⁾

Standard Finishes		
Sprinkler	Escutcheon	Cover plate
Bronze	Brass	
Chrome Plated	Chrome	Chrome
White Polyester Coated ⁽⁴⁾⁽⁵⁾	Plated White Painted	White
Special Application Finishes		
Sprinkler	Escutcheon	Cover plate
Bright Brass ⁽³⁾	Bright Brass	Bright Brass
Black Plated	Black Plated	Satin
Black Paint ⁽²⁾	Black Paint	Off White
Off White ⁽²⁾	Off White	Black Paint
Satin Chrome	Satin Chrome	Black Plated

⁽¹⁾ Other finishes and colors are available on special order.

Consult the factory for details.

⁽²⁾ cULus Listed only.

⁽³⁾ 200°F (93°C) maximum.

⁽⁴⁾ cULus listed "corrosion resistance" applies to SIN Numbers RA1425 (Upright) and RA1414 (Pendent).

⁽⁵⁾ FM Approvals finish as "Polyester coated" applies to SIN Number RA1414 (Pendent).

Ordering Information

Specify:

1. Sprinkler Model
2. Sprinkler Type
3. Orifice Size
4. Deflector Type
5. Temperature Rating
6. Sprinkler Finish
7. Escutcheon Type
8. Escutcheon Finish (where applicable)
9. Cover plate Model
10. Cover plate Thread size
11. Cover plate Temperature
12. Cover plate Adjustment
13. Cover plate Finish

Note: When Model F1FR 56 Recessed sprinklers are ordered, the sprinklers and escutcheons are packaged separately.

The equipment presented in this bulletin is to be installed in accordance with the latest published Standards of the National Fire Protection Association, Factory Mutual Research Corporation, or other similar organizations and also with the provisions of governmental codes or ordinances whenever applicable. Products manufactured and distributed by Reliable have been protecting life and property for over 80 years, and are installed and serviced by the most highly qualified and reputable sprinkler contractors located throughout the United States, Canada and foreign countries.

Manufactured by



The Reliable Automatic Sprinkler Co., Inc.
(800) 431-1588 Sales Offices
(800) 848-6051 Sales Fax
(914) 829-2042 Corporate Offices
www.reliablesprinkler.com Internet Address



Revision lines indicate updated or new data.

EG. Printed in U.S.A 12/09 P/N 9999970300