

# Reliable®

## Model F4FR-NF Non-Ferrous Quick Response Concealed Automatic Sprinkler for MRI Type Applications

### The Non-Ferrous Concealer®

#### Features

1. Completely Non-Ferrous material designed for MRI rooms.
2. Laboratory tested in an MRI room environment.
3. Cup and skirt fabricated from brass.
4. Simple sturdy cover attachment.
5. Smooth aesthetic ceiling profile.
6. Available in bright brass, chrome and black plated, and white or other color painted finishes.
7. Ordinary temperature rating.
8. Threaded cover plate does not require clips or springs.

#### Listings and Approvals

1. Listed by Underwriters' Laboratories Inc. and UL certified for Canada (cULus).
2. NYC MEA 258-93-E

**Note:** Approvals are light and ordinary hazard.

#### UL Listing Categories

Sprinklers, Automatic & Open  
Quick Response Sprinkler

#### UL Guide Number

VNIV

#### U.S. Patent No. 4,880,063.

#### Application

The Reliable Model F4FR-NF Non-Ferrous Concealer® is the only sprinkler designed specifically for MRI rooms. A test setup of the sprinkler assembly was tested in a laboratory with a magnetic field up to 6 Tesla.

The highest clinical magnet system commercially available today is 3 Tesla. There was no recorded influence of the magnetic field on the sprinklers. The test exposed the sprinklers to magnetic fields and field gradients that would far exceed a standard peripheral MRI room environment.

The Model F4FR-NF is the most versatile quick response sprinkler available. This sprinkler provides the best form of fire protection by offering an attractive appearance and ½" (13mm) cover adjustment for ease of installation. The small diameter cover plate is easily and positively attached and

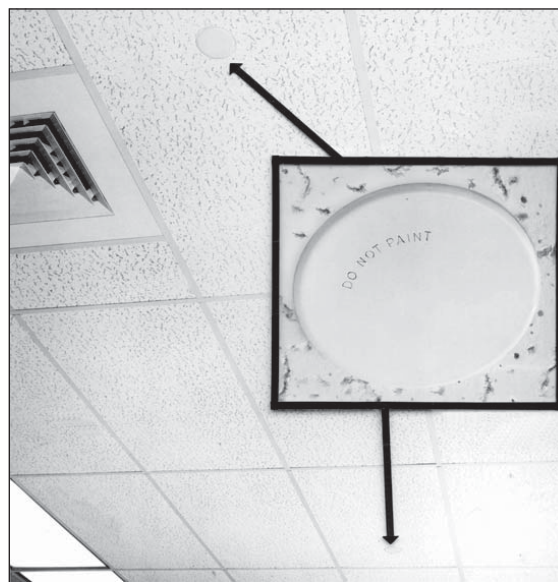

blends into the ceiling, concealing the most dependable fire protection available, an automatic sprinkler system.

The Model F4FR-NF a Non-Ferrous Concealer® is designed for use where aesthetic appearance is important. It is a quick response concealed sprinkler intended for use in accordance with NFPA 13. The Non-Ferrous Concealer® can eliminate the need for precise cutting of drop nipples. The threaded cover plate assembly can be adjusted without tools to fit accurately against the ceiling. The fire protection system need not be shut down to adjust or remove the cover plate assembly.

#### Product Description

The Non-Ferrous Concealer® for quick response applications uses a 135°F (57°C) 3mm diameter glass bulb in a standard style sprinkler frame with a drop-down deflector. This assembly is recessed into the ceiling and concealed by a flat cover plate. The cover plate and sprinkler cup assemblies are attached using a strong threaded engagement. This threaded engagement provides ½" (13mm) of cover adjustment. The cover plate is attached to the skirt using 135°F (57°C) ordinary temperature classification solder. When the ceiling temperature rises, the solder holding the cover plate fuses, thus releasing the plate and exposing the sprinkler inside to ambient temperature. The subsequent shattering of the sprinkler bulb opens the waterway and causes the deflector to drop into position to distribute the discharging water. Any secure engagement between the cover plate and cup will assure that the drop-down deflector is properly located below the ceiling.

## Installation

Do not install The Non-Ferrous Concealer® in ceilings which have positive pressure in the space above. In addition, inspect all sprinklers after installation to ensure that both the gap between the cover plate and ceiling and the four (4) slots in the cup are open and free from any air flow impediment.

After a 2<sup>5</sup>/<sub>8</sub>" diameter hole is cut in the ceiling, the sprinkler is to be installed with the Model G4 Wrench. When installing a sprinkler, the wrench is first positioned into the sprinkler/cup assembly until two wrench tangs fully engage drive slots in the top of the cup (there are two pairs of drive slots in the cup). The sprinkler is then tightened into the pipe fitting to a torque of 15-20 ft-lbs. When inserting or removing the wrench from the sprinkler/cup assembly care should be taken to prevent damage to the sprinkler. **DO NOT WRENCH ON ANY OTHER PART OF THE SPRINKLER/CUP ASSEMBLY.**

## Maintenance

The Model F4FR-NF should be inspected quarterly and the sprinkler system maintained in accordance with NFPA 25. Do not clean sprinklers with soap and water, ammonia or any other cleaning fluids. Remove any sprinkler that has been painted ( other than factory applied) or damaged in any way. A stock of spare sprinklers should be maintained to allow quick replacement of damaged or operated sprinklers. Prior to installation, sprinklers should be maintained in the original cartons and packaging to minimize the potential for damage to sprinklers that would cause improper operation or non-operation.

## Engineering Specification

Sprinklers shall be cULus Listed, non-ferrous, quick response concealed pendent sprinklers specifically designed and tested for use in MRI type applications, and able to withstand exposure to a magnetic field of up to 6 Tesla. The concealed sprinkler frame and cover plate assembly shall be of all brass construction, including the drop-down deflector and sprinkler cup assembly. The water seal shall consist of a Teflon film coated Belleville spring washer and bulb/machined cup assembly utilizing a 3 mm glass bulb thermal element.

## Temperatures Ratings

| Classification | Sprinkler                | Cover Plate | Max. Ceiling Temp. |
|----------------|--------------------------|-------------|--------------------|
| Ordinary       | 135°F/57°C<br>155°F/68°C | 135°/57°C   | 100°F/38°C         |

## Installation Data

| Total Adjustment | Nominal Orifice | Nominal K Factor |        | Thread          | Approval | Sprinkler Identification Number (SIN) |
|------------------|-----------------|------------------|--------|-----------------|----------|---------------------------------------|
|                  |                 | US               | Metric |                 |          |                                       |
| 1/2" (13mm)      | 1/2" (15mm)     | 5.6              | 80     | 1/2" NPT (R1/2) | cULus    | RA0212                                |

The equipment presented in this bulletin is to be installed in accordance with the latest published Standards of the National Fire Protection Association, Factory Mutual Research Corporation, or other similar organizations and also with the provisions of governmental codes or ordinances whenever applicable.

Products manufactured and distributed by Reliable have been protecting life and property for over 90 years, and are installed and serviced by the most highly qualified and reputable sprinkler contractors located throughout the United States, Canada and foreign countries.

Manufactured by



The Reliable Automatic Sprinkler Co., Inc.  
 (800) 431-1588 Sales Offices  
 (800) 848-6051 Sales Fax  
 (914) 829-2042 Corporate Offices  
 www.reliablesprinkler.com Internet Address



Revision lines indicate updated or new data.

EG. Printed in U.S.A. 12/11 P/N 9999970241

Concealed sprinklers shall have a 1/2" NPT with a nominal K-factor of 5.6 (80.0). Temperature rating of both the sprinkler and the cover plate shall be 135 °F (57 °C). Sprinkler cover plate shall be capable of providing 1/2" of adjustment and shall attach to the sprinkler cup by a strong threaded engagement. The sprinkler cup shall be reinforced with an attached brass wrenching plate to protect the sprinkler cup from damage during installation. Concealed sprinklers shall be UL Listed for Light Hazard and Ordinary Hazard occupancies. Standard cover finish to be: [Bronze] [Chrome Plated] [White] [Bright Brass Plated] [Black Plated] [Specialty – specify]. Quick Response Concealed Pendent Sprinklers shall be the Reliable Non-Ferrous Concealer, Model F4FR-NF, SIN RA0212.

## Ordering Information

- Specify
1. Sprinkler Model
  2. Cover Plate Finish

## Installation Wrench

Model G4 Sprinkler Wrench

## Finishes (1):

| Standard Finishes:  |
|---------------------|
| Bronze              |
| Bright Brass Plated |
| Chrome Plated       |
| Black Plated        |
| White               |

**Note:** Paint or any other coatings applied over the factory finish will void all approvals and warranties.

(1) Other colors and finishes are available.

Consult factory for details.

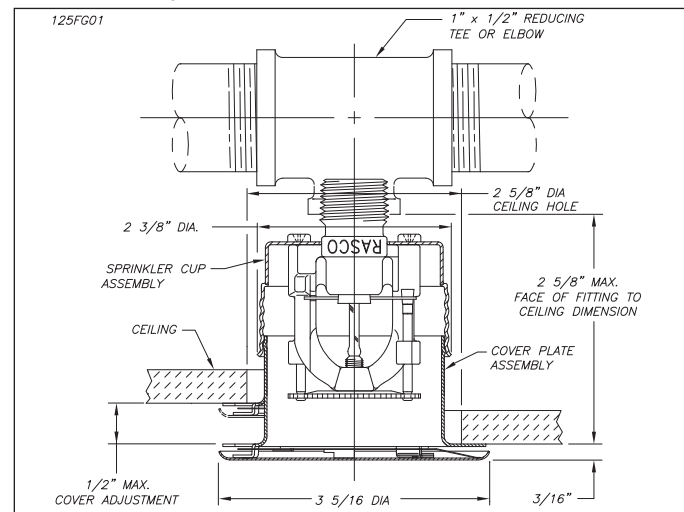

1/2" NPT (R1/2) inlet - Figure 1