

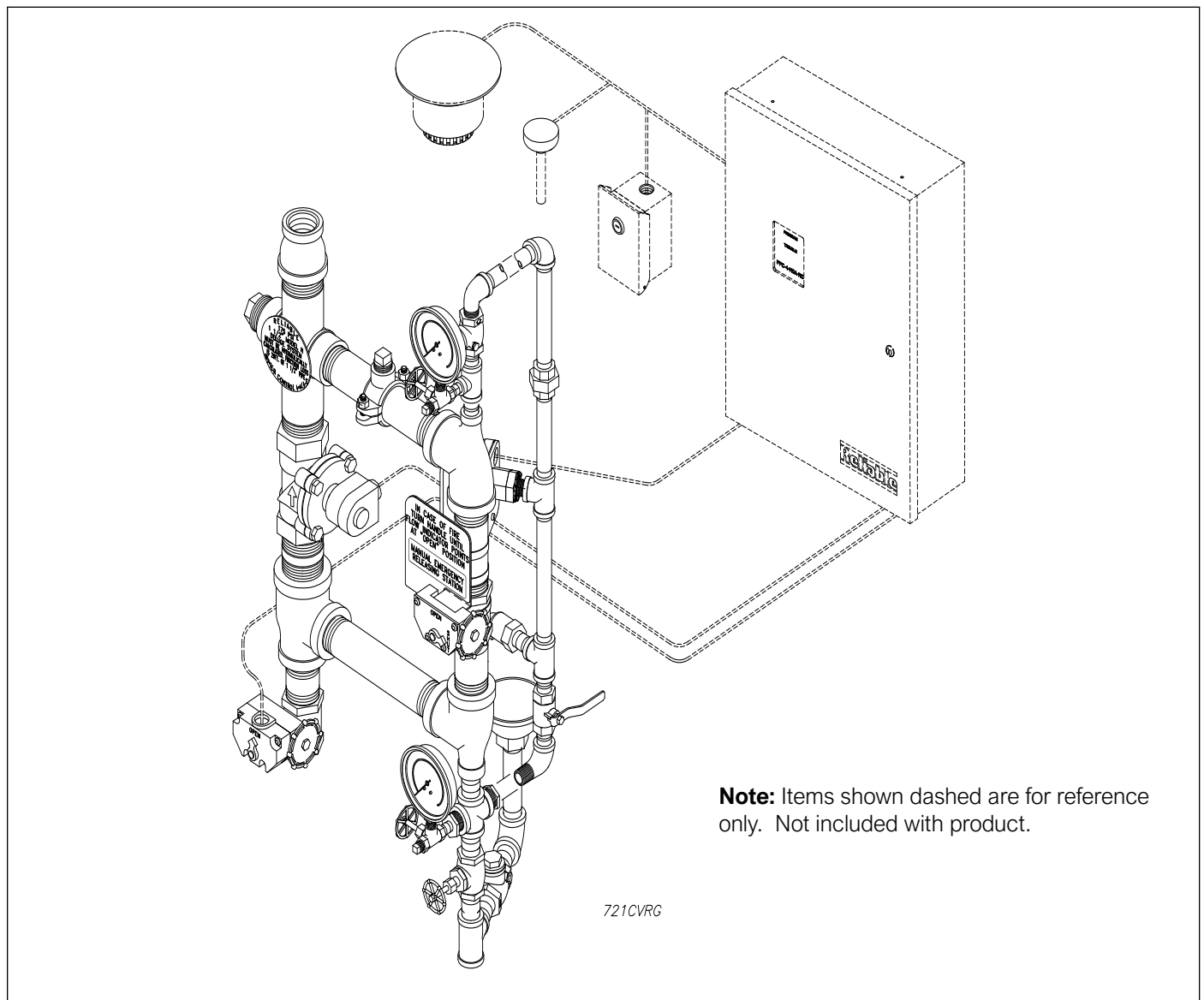

Model H Single Interlock Preaction System 1½" (40mm)

Instructions for Installation, Operation, Care and Maintenance

For Non-Supervised Single Interlock Systems
With Electric Actuation



Note: Items shown dashed are for reference only. Not included with product.

General Description

Reliable Single Interlock Preaction Systems are designed for water sensitive areas which require protection from inadvertent water flow into the sprinkler system piping.

Sprinkler piping in single interlock systems can effectively be supervised by means of a Reliable Model B Air Compressor Panel or Model C Pressure Maintenance Device (Ref. Bulletin 719). However, supervision of sprinkler piping is not required by NFPA 13 when there are 20 or less sprinklers on the system. This bulletin pertains to Reliable Single Interlock Systems of 20 sprinklers or less.

When one electrical detector senses the presence of fire, the electrical releasing control panel activates fire alarm devices and latches the solenoid releasing valve in the open position (note that arranging detectors in a cross-zoned pattern will require operation of two detectors before the solenoid valve can open). The solenoid valve, when closed, is preserving supply water pressure in the inlet of the Reliable Model H Deluge Riser Assembly. Actuating the solenoid valve releases that water pressure, allowing water flow into the sprinkler system in readiness for the subsequent operation of a sprinkler.

To fully operate a cross-zoned single interlock system, two electrical detectors must activate and a sprinkler must open. During the early stages of a fire, smoke or heat activates the first detector which causes the control panel to produce a local alarm and an alarm at the main fire alarm panel. Electrical relays inside the releasing control panel can be used to shut down air moving equipment or activate security doors and other electrical devices when the panel goes into the "first alarm" condition. Subsequent activation of a second, nearby or adjacent, detector will cause the panel to energize the solenoid valve open and release water into the sprinkler piping. Water flowing into the sprinkler piping will simultaneously produce water pressure that causes the transfer of contacts in the pressure switch mounted in the Riser Assembly. This switch can electrically initiate the shutdown (or startup) of equipment, such as computers or other "second alarm" devices. The flow of water into the sprinkler piping effectively converts the dry system into a wet pipe system. In the event the fire subsequently produces sufficient heat to operate a sprinkler head, water will flow from that sprinkler, controlling or suppressing the fire.

The major benefits of a non-supervised Reliable Single Interlock Preaction System, when compared with a wet pipe system, are as follows:

- A. A fire alarm sounds prior to the operation of a sprinkler, which may enable extinguishing the fire by handheld means before the operation of any sprinkler head occurs.
- B. Whenever the integrity of piping or sprinklers is accidentally or intentionally disturbed, no water flow or water damage will result at that time.
- C. Speedy detection and an early fire alarm are provided by fire detectors, without significant time delay associated with water discharge on a fire. Note that with a wet pipe system, the fire alarm is delayed until after water has begun flowing from an operated sprinkler head.

A hydraulic manual emergency releasing station is standard equipment in the Riser Assembly. It is identified by a nameplate attached above the valve.

The Single Interlock Preaction Assembly illustrated in Figure 2 is pre-assembled, as shown, for use without supervision in systems for 20 sprinklers or less.

Approvals

The 1½" (40mm) Reliable Single Interlock Preaction assembly is Underwriters Laboratories, Inc. Listed in the Special System Water Control Valves - Deluge Type (VLFT) category. Only the components shown in Fig. 2 of this bulletin may be used in combination.

Also the Model H Riser Assembly is Underwriters' Laboratory of Canada Listed, and approved by New York City (MEA 258-93-E).

Technical Data

The 1½" (40mm) Reliable Single Interlock Preaction Assembly is rated for a minimum supply pressure of 20 psi (1.30 bar) and a maximum supply pressure of 175 psi (12.07 bar).

Note: 1 bar=100 kPa

Friction loss, expressed in equivalent length of Sch. 40 pipe and based on Hazen & Williams formula with C= 120, is 29 ft. (8.84m) for the entire Riser Assembly.

Shipping Weight:

Model H Riser Assembly 52 lbs. (23.3 kg)

The following list of bulletins describe components which can be used in this system.

Deluge Riser Assembly	507
Water Flow Pressure Alarm Switch	Potter #5400928
Releasing/Control Panel	Potter #5403550

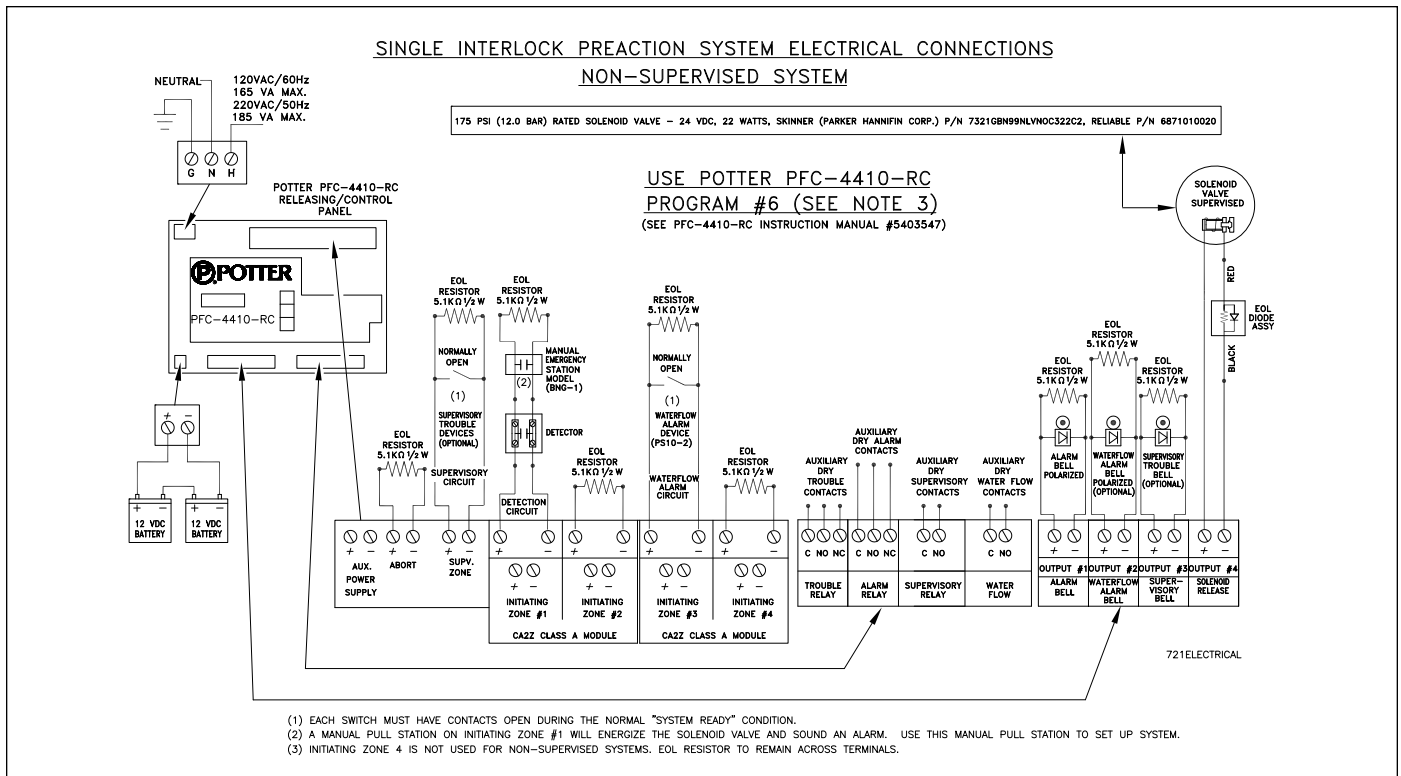

Figure 1

System Design Considerations

The automatic sprinklers, releasing devices, electric releasing control equipment, fire detection devices, manual pull stations, and signaling devices which are utilized with the Reliable Single Interlock System must be UL and/or ULC listed, as applicable.

The Single Interlock Riser Assembly (Figure 2) and all interconnecting piping must be located in a readily visible and accessible location and in an area which can be maintained at a minimum temperature of 40F/4C.

NOTE: HEAT TRACING IS NOT PERMITTED

The solenoid valve is operated and supervised by the electric releasing control panel. Details on connecting the electrical portion of the system to a Notifier Potter PFC-4410-RC Releasing/Control Panel is indicated in Figure 1.

Hydrostatic Testing of Systems

As required by NFPA 13, fire sprinkler systems with working pressures up to and including 150 psi are to be hydrostatically tested at a water pressure of 200 psi and maintain that pressure without loss for two hours. Fire sprinkler systems with working pressures above 150 psi are required to be hydrostatically tested at 50 psi above the system working pressure and maintain that pressure without loss for two hours. In addition to the hydrostatic tests described above, dry pipe and double interlock preaction systems require an additional low pressure air test.

In some cases, hydrostatic testing (in accordance with the NFPA 13 requirements noted above) will result in pressures that exceed the working pressure of the valve and trim kit for the two-hour test period. The valve and applicable trim kit have been tested, approved and listed under these conditions and as such, hydrostatic testing in accordance with NFPA 13 is acceptable. In addition, the clapper can remain in the closed position and the trim kit need not be isolated, as each has been designed to withstand hydrostatic testing as required by NFPA 13.

Hydrostatically testing the valve and trim to pressures higher than their rating is limited to the hydrostatic test as referenced by NFPA 13. It does not address the occurrence(s) of a "water hammer" effect, which can indeed damage the valve. A "water hammer" in the water supply piping of the valve can create pressures in excess of the rated pressure and should be avoided by all necessary means. This condition may be created from improper fire pump settings, underground construction work, or an improper venting of trapped air in the water supply piping.

System Electrical Requirements

All releasing, alarm and detection devices in the Single Interlock System can be supervised by the Potter PFC-4410-RC Releasing/Control Panel. Typical connection of these devices is shown in Fig. 1.

The power supply, standby emergency power supply, battery charger and rectifier circuitry are all contained within the Potter PFC-4410-RC Releasing/Control Panel.

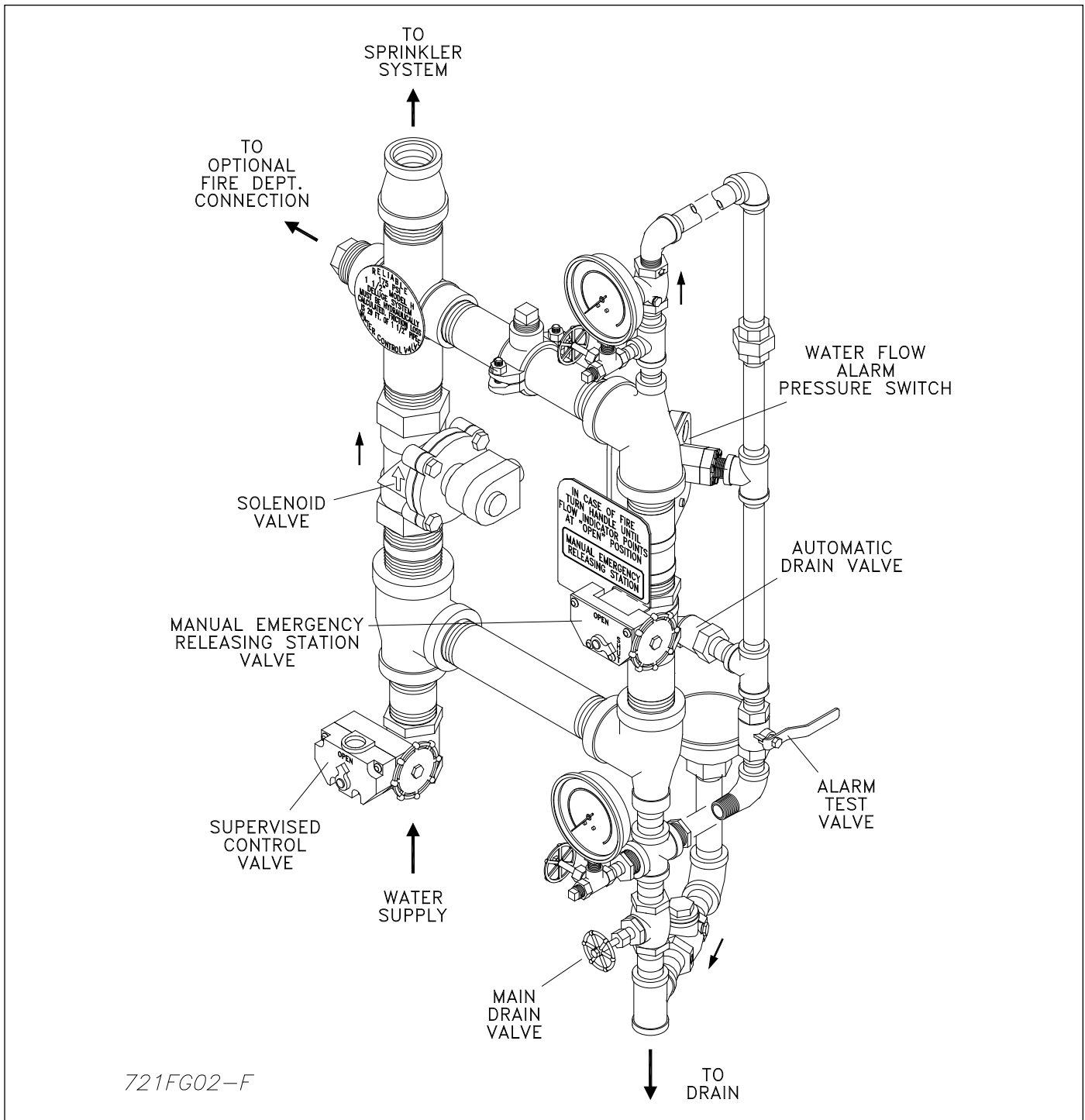

Fig. 2 - Model H Riser Assembly Preassembled (P/N 6503003001)

System Operation

To activate a Reliable Single Interlock System, two independent events must coexist before water can flow from the system to the fire. One electrical detector (two detectors in a cross-zoned system) must activate and a sprinkler head must open.

When a fire is detected, the releasing control panel energizes the solenoid valve open and water flows from the supply through the Riser Assembly to the system and to the alarm initiation switch. The valve maintains its open position until the solenoid is de-energized.

Caution: The solenoid valve must be maintained open to prevent automatic closing of the Model H Riser Assembly. The Potter PFC-4410-RC Releasing/Control Panel has a latching feature for this purpose.

After system shutdown, the Riser Assembly is easily reset without special tools. Restore detection devices by resetting or replacing any operated devices. Once detection devices are restored, reset the Releasing/Control Panel, and restore the supply pressure (see Bulletin 507).

Single Interlock Riser Installation

The recommended sequence of installation is as follows (refer to Figure 3):

1. Install the Riser Assembly portion in accordance with Bulletin 507, "Model H Deluge Riser Assembly."
2. Make all electrical connections in accordance with Fig. 1.

Maintenance

The Reliable Single Interlock System and associated equipment shall periodically be given a thorough inspection and test. NFPA 25, "Inspection, Testing and Maintenance of Water Based Fire Protection Systems," provides minimum maintenance requirements. A single interlock system should be tested, operated, cleaned and inspected at least annually, and parts replaced as required. Refer to Bulletin 507 for information regarding maintenance of the Solenoid Valve and Manual Emergency Station Valve.

Resetting Single Interlock System

Refer to Fig. 2.

1. Close the valve controlling water supply to the Riser Assembly.
2. Open drain valve and the manual emergency station valve to drain the system.
3. Open all drain valves and vents at low points throughout the system, closing them when flow of water has stopped.
4. Inspect and replace any portion of the sprinkler system and detection system exposed to fire conditions. Reset detectors and Potter PFC-4410-RC Releasing/Control Panel. This action will close (reset) the solenoid valve also.
5. Reset the Riser Assembly in accordance with Bulletin 507, "Model H Deluge Riser Assembly Instructions for Installation, Operation, Care and Maintenance."
6. Verify that the control valve is open, and properly supervised. Also, verify there is no leakage from the automatic drain valve.

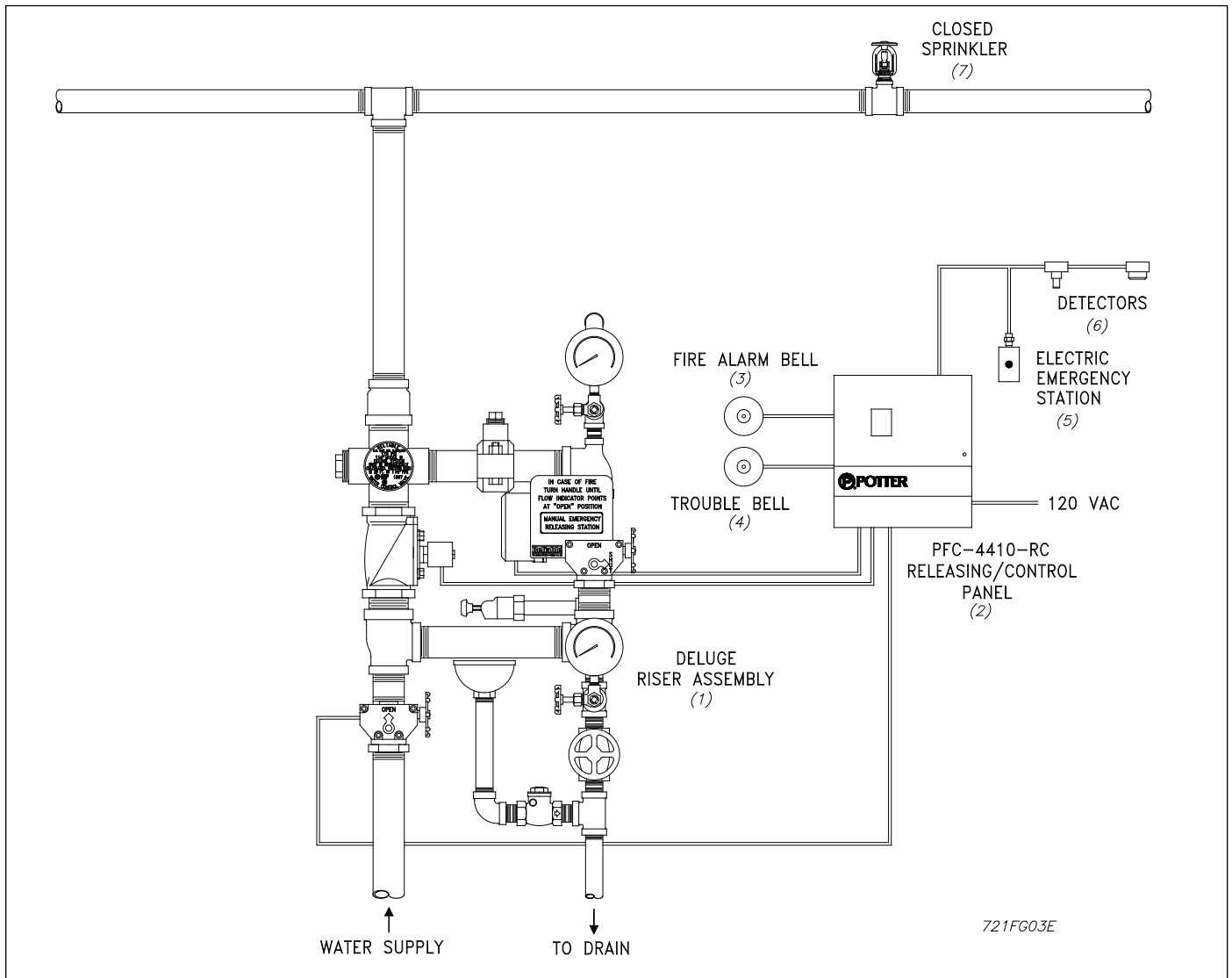

Fig. 3 - Non-Supervised Single Interlock Preaction System Recommended Arrangement

Note: Final arrangement of detection, release, and alarm components (not included) are the responsibility of the installing contractor.

Inspection and Testing

Refer to Figs. 2 and 3

1. Water supply - be sure the valve controlling water supply to the Riser Assembly is open fully and monitored properly.
2. Other trimming valves - check that all pressure gauge valves are open, and that all gauges are indicating proper air or water pressure readings.
3. Test water flow alarm devices by opening alarm test valve. After closing alarm test valve, push plunger on automatic drain valve to verify water has drained from alarm line.
4. The Automatic Drain Valve is for monitoring internal leakage past the solenoid valve or manual emergency station valve. Push in on the plunger. If no water discharges and the drip cup is dry, the Riser Assembly is leak tight.
5. Operation test-operate by electrical actuation.

Note: An operation test will cause water flow through the Riser Assembly and into the system. Where difficulty in performance is experienced, contact Reliable Technical Services before any field adjustment is to be made.

Testing Detection System Without Causing Water Flow

Refer to Figs. 2 and 3

1. Close the valve controlling water supply to the Riser Assembly, and note the water pressure gauge reading.
2. Operate the detection system - operate a cross-zoned releasing control panel by operating two detectors.
3. Operation of the detection system must result in a sudden drop of water pressure as the solenoid valve opens. When the water pressure gauge drops to zero, open the drain valve until all water above the closed control valve drains away.
4. Reset detection system - reverse operations performed in Step 2 above. All detection devices must be reset before the Potter PFC-4410-RC Releasing/Control Panel can be reset. The solenoid valve closes when the releasing panel is reset.
5. Open slightly the valve controlling water supply to the Riser Assembly, closing the drain valve when water flows steadily. Open slowly but fully the control valve and supervise it properly. Push plunger on the automatic drain valve to verify all water has drained from the alarm line. Observe that the water gauge is indicating the correct water supply pressure.

Guarantee

For guarantee, terms, and conditions, please visit www.reliablesprinkler.com.

Ordering Information:

Specify:

Model H 1-1/2" Deluge Riser Assembly PN 6503003001

All other accessories to be ordered separately.

Installation Dimensions in Inches

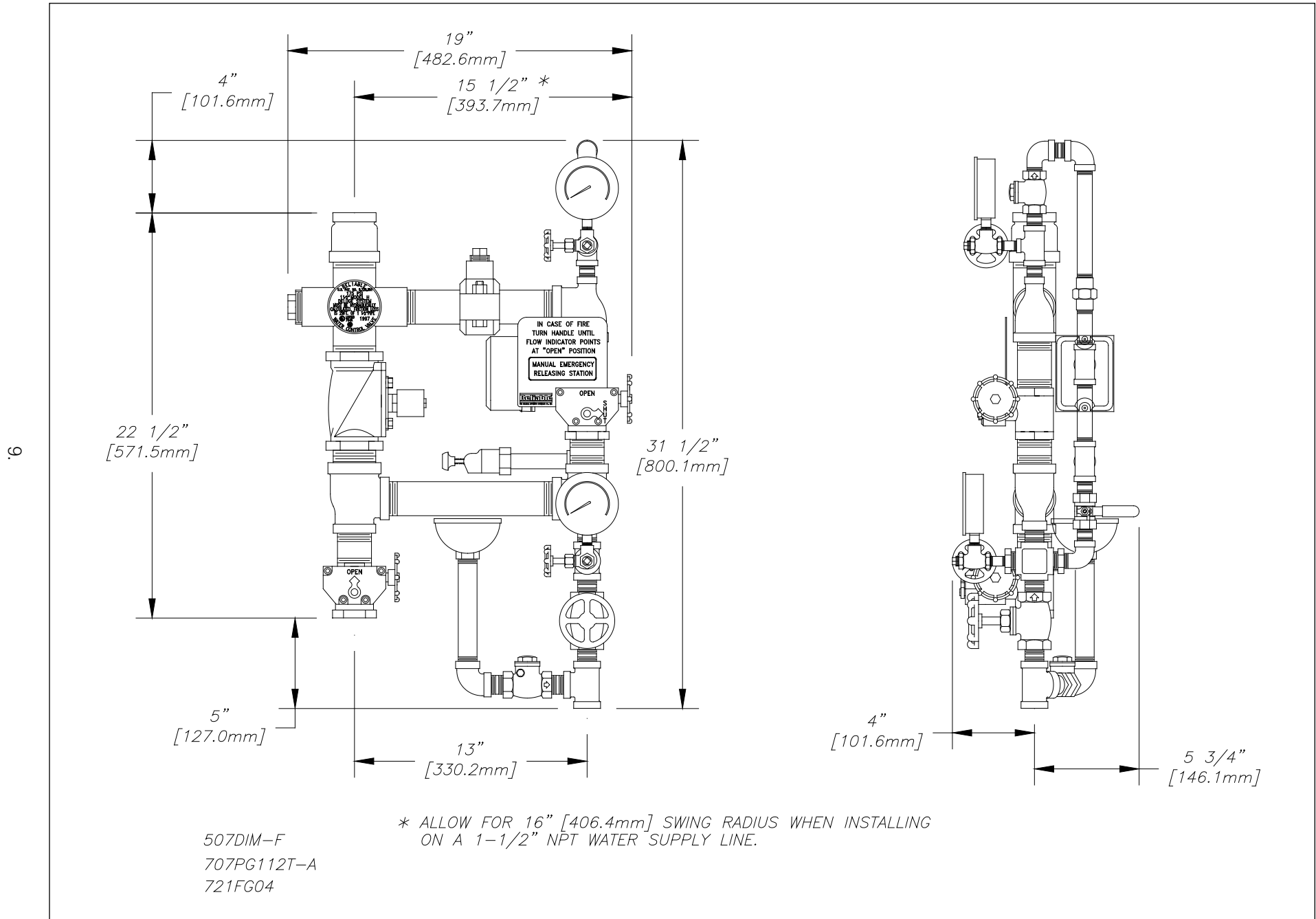

SOLENOID VALVE INSPECTIONS, TESTS AND MAINTENANCE

WARNING: THE OWNER IS RESPONSIBLE FOR MAINTAINING THE FIRE PROTECTION SYSTEM IN PROPER OPERATING CONDITION. ANY SYSTEM MAINTENANCE OR TESTING THAT INVOLVES PLACING A CONTROL VALVE OR DETECTION SYSTEM OUT OF SERVICE MAY ELIMINATE THE FIRE PROTECTION OF THAT SYSTEM. PRIOR TO PROCEEDING, NOTIFY ALL AUTHORITIES HAVING JURISDICTION. CONSIDERATION SHOULD BE GIVEN TO EMPLOYMENT OF A FIRE PATROL IN THE AFFECTED AREA.

WARNING: PRIOR TO OPERATING THE SOLENOID VALVE, BE SURE TO CLOSE THE SYSTEM CONTROL VALVE TO AVOID UNINTENTIONAL OPERATION OF THE DELUGE VALVE

1. Inspections: It is imperative that the system be inspected and tested in accordance with NFPA 25 on a regular basis. The frequency of the inspections may vary due to contaminated water supplies, corrosive water supplies, or corrosive atmospheres. In addition, the alarm devices, detection systems, or other connected trim may require a more frequent schedule. Refer to the system description and applicable codes for minimum requirements.
2. The valve must be inspected at least monthly for cracks, corrosion, leakage, etc., and cleaned, repaired, or replaced, or replaced as necessary.
3. If leakage is suspected through the solenoid valve, the valve diaphragms and seats should be inspected and if necessary, repaired or replaced.

WARNING: CLOSE SYSTEM CONTROL VALVE, TURN OFF POWER SUPPLY, AND DEPRESSURIZE VALVE BEFORE DISASSEMBLING VALVE. IT IS NOT NECESSARY TO REMOVE THE VALVE FROM THE PIPE LINE TO MAKE INSPECTIONS.

4. When lubricating valve components, use high grade silicone grease (Dow Corning® 111 Compound Lubricant or equal).
5. When reassembling, tighten parts to torque values indicated in the manufacturer's maintenance instructions (packed with valve).
6. After maintenance is completed, operate the valve a few times to be sure of proper operation. A metallic "click" signifies the solenoid is operating.
7. All service must be performed by qualified personnel. Upon completion of inspections or replacement of the valve, the entire system must be checked for proper operation. See appropriate system description and testing instructions for additional information.

The equipment presented in this bulletin is to be installed in accordance with the latest published Standards of the National Fire Protection Association, Factory Mutual Research Corporation, or other similar organizations and also with the provisions of governmental codes or ordinances whenever applicable. Products manufactured and distributed by Reliable have been protecting life and property for over 100 years.

Manufactured by

Reliable®

Reliable Automatic Sprinkler Co., Inc.

(800) 431-1588

(800) 848-6051

(914) 829-2042

www.reliablesprinkler.com

Sales Offices

Sales Fax

Corporate Offices

Internet Address



Recycled
Paper

Revision lines indicate updated or new data.

EG. Printed in U.S.A 09/21

P/N 9999970137