



F1FR42 Series Quick-Response Sprinklers

K-factor 4.2 (60)

Features

- Standard coverage quick-response sprinklers
- Upright and pendent deflectors
- Low profile, compact design
- Available in a wide variety of finishes

Product Description

Reliable Model F1FR series sprinklers are quick-response standard spray automatic fire sprinklers utilizing a sensitive 3.0 mm glass bulb thermal element.

Pendent and horizontal sidewall sprinklers may be installed exposed or surface mounted using escutcheons such as the Reliable Models B, C, or HB (reference Technical Bulletin 204). When installed recessed, the Model F1FR42 series sprinklers are specifically listed with and may only be installed with listed Reliable escutcheons. Refer to the technical information on the following pages for specific listings for recessed installations and refer to Figure 3 for dimensional information.

When fitted with an approved water shield, these sprinklers may be considered intermediate sprinklers for use in racks, below grated walkways, and other areas where intermediate level sprinklers are required.

Table A provides a summary of the approvals and availability of specific Model F1FR series sprinkler configurations. Additional technical information for each sprinkler model is provided on the following pages.

Note: This bulletin may contain information on New and Legacy sprinklers that reflects a dimensional change only. Sprinkler Identification Number (SIN), application, performance, and listings/approval are not otherwise affected. Sprinklers with new frames can be identified by a rotoclip indent on one side of the wrench boss and in some cases an installed rotoclip. Sprinklers with new frames will include the suffix "N" in the order. For reference only, legacy version of this sprinkler can be found on Technical Bulletin 014.



Model F1FR42 Pendent



Model F1FR42 Upright

Note: Not all versions of the product are shown.

F1FR42 Series Sprinkler Summary

Table A

Sprinkler Model	K-Factor gpm/psi ^{1/2} (lpm/bar ^{1/2})	Orientation	Listings & Approvals	Max. Working Pressure psi (bar)	Sprinkler Identification Number (SIN)
F1FR42	4.2 (60)	Upright	cULus	175 (12)	RA1423
		Pendent		175 (12)	RA1413

Model F1FR42 Upright Sprinkler

SIN RA1423

Technical Specifications

Style: Upright
Threads: 1/2" NPT or ISO 7-R1/2
Nominal K-Factor: 4.2 (60)
Max. Working Pressure: 175 psi (12 bar)

Material Specifications

Thermal Sensor: 3 mm Glass Bulb
Sprinkler Frame: Brass Alloy
Cap: Bronze Alloy
Sealing Washer: Nickel with PTFE
Load Screw: Copper Alloy
Deflector: Brass Alloy

Sprinkler Finishes

(See Table B)

Sensitivity

Quick Response

Temperature Ratings

135°F (57°C)
 155°F (68°C)
 175°F (79°C)
 200°F (93°C)
 286°F (141°C)

Guards & Shields (New Frames)

F-1 Guard Kit
 F-3 Guard/Shield Kit

Guards & Shields (Legacy Frames)

D-1 Guard

Sprinkler Wrenches

Model W2
 Model W14 (New frame with guard installed)
 Model W13 (Legacy frame with guard installed)

Listings and Approvals

cULus



Model F1FR42 Upright Sprinkler Components and Dimensions

Figure 1

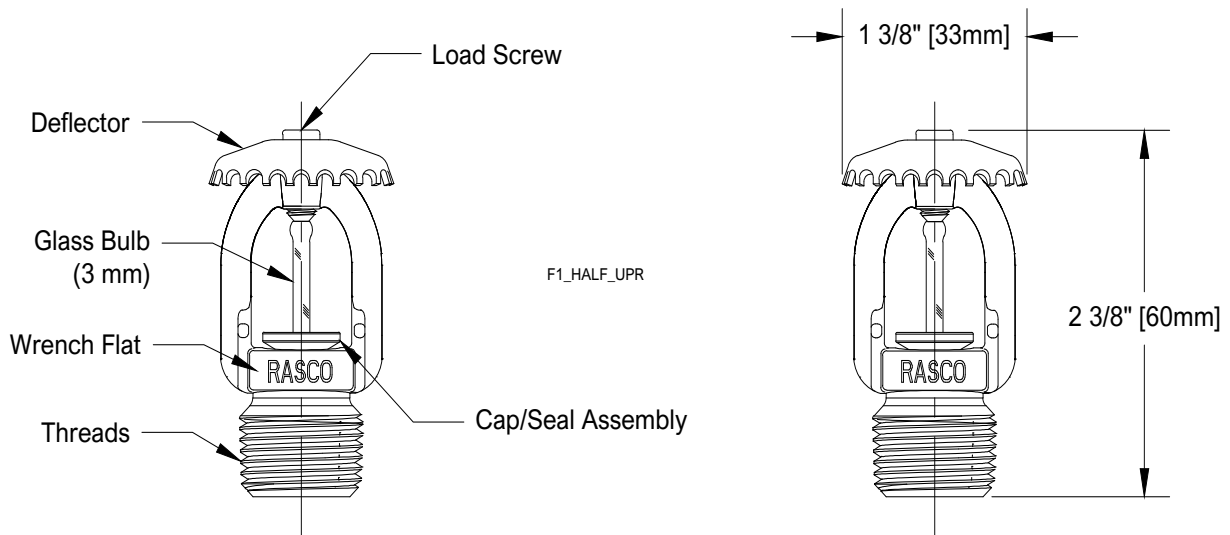

Technical Specifications

Style:
 Pendent
 Recessed Pendent
Threads: 1/2" NPT or ISO 7-R1/2
Nominal K-Factor: 4.2 (60)
Max. Working Pressure: 175 psi (12 bar)

Material Specifications

Thermal Sensor: 3 mm Glass Bulb
Sprinkler Frame: Brass Alloy
Cap: Bronze Alloy
Sealing Washer: Nickel with PTFE
Load Screw: Copper Alloy
Deflector: Brass Alloy

Sprinkler Finishes

(See Table B)

Sensitivity

Quick Response

Temperature Ratings⁽¹⁾

135°F (57°C)
 155°F (68°C)
 175°F (79°C)
 200°F (93°C)
 286°F (141°C)

Recessed Escutcheons

Model F1
 Model F2
 Model FP

Guards & Shields (New Frames)⁽²⁾

F-7 Guard Kit
 F-8 Guard/Shield Kit

Guards & Shields (Legacy Frames)⁽²⁾

D-1 Guard

Sprinkler Wrenches

Model W2 (pendent)
 Model W4 (recessed)
 Model W14 (New frame with guard installed)
 Model W13 (Legacy frame with guard installed)

Listings and Approvals

cULus



Notes:

1. 286°F (141°C) and higher temperature rated sprinklers not listed for recessed use.
2. Not suitable for recessed pendent installations.

Model F1FR42 Pendent Sprinkler Components and Dimensions

Figure 2

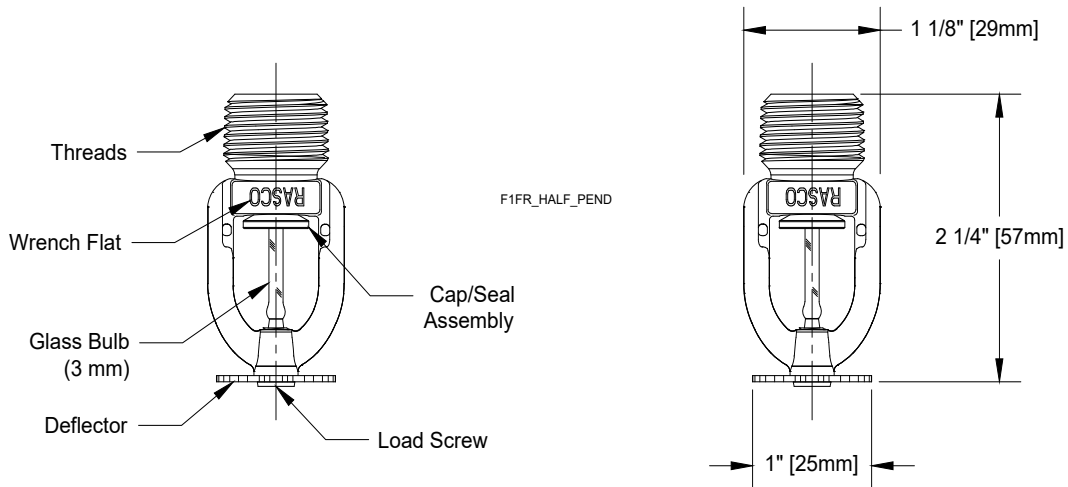

Note: Please refer to Figure 3 for recessed installation.

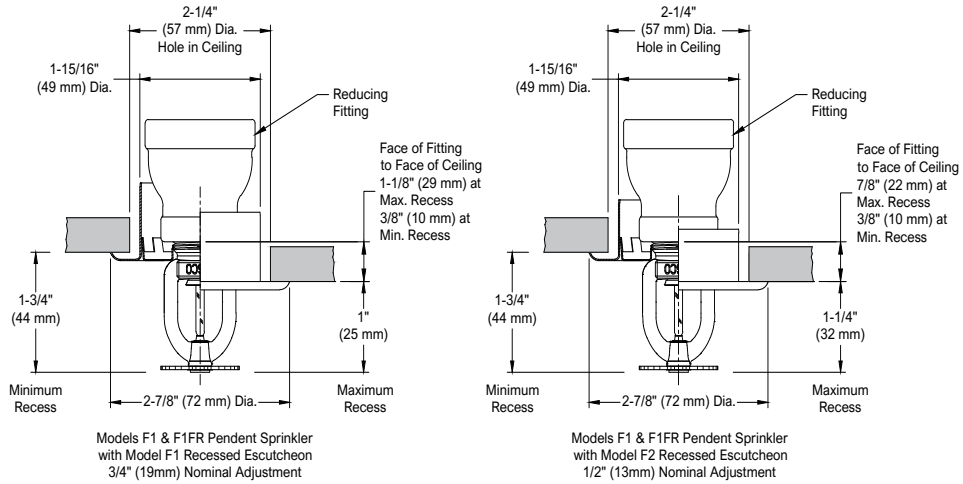

F1_REC_PEND

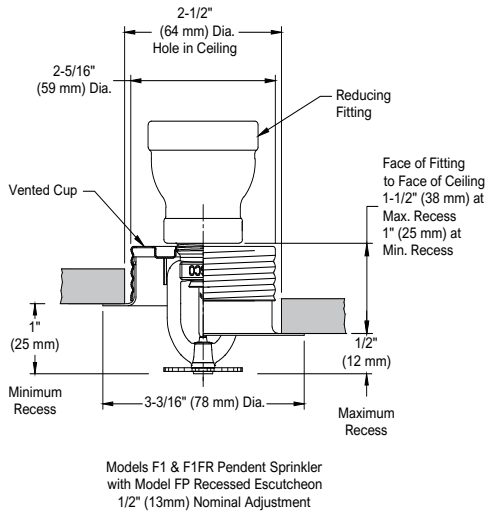

Note: Model FP recessed assemblies may not be used where the pressure in the space above the ceiling is positive with respect to the protected area. Ensure that the openings in the Model FP cup are unobstructed following installation.



Wrenches



Model W2 (upright, pendent)



Model W13 (Legacy frame with guard installed)



Model W14 (New frame with guard installed)



Model W4 (recessed pendent)



Model JD (Legacy frame with guard installed)

Finishes⁽¹⁾

Table B

Standard Finishes		Special Application Finishes	
Sprinkler	F1, F2 and FP ⁽²⁾ Escutcheons	Sprinkler	F1, F2 and FP ⁽²⁾ Escutcheons
Bronze	Brass	Electroless Nickel PTFE ⁽³⁾	Bright Brass
Chrome Plated	Chrome Plated	Bright Brass ⁽⁴⁾	Satin Chrome
White Polyester ⁽³⁾	White Polyester	Satin Chrome	Custom Color Polyester
		Custom Color Polyester ⁽³⁾	

Notes:

1. Paint or any other coating applied over the factory finish will void all approvals and warranties.
2. Model FP escutcheons utilize a galvanized steel cup with a finished trim ring.
3. cULus Listed as corrosion resistant.
4. For 200°F (93°C) maximum temperature rated sprinklers only.

Installation

Model F1FR Series sprinklers must be installed in accordance with NFPA13 and the requirements of all applicable authorities having jurisdiction. Model F1FR Series sprinklers must be installed with the Reliable sprinkler installation wrench identified in this Bulletin. Any other wrench may damage the sprinkler. A leak tight sprinkler joint can be obtained with a torque of 6 to 18 lb-ft (11 to 24 N-m). Do not tighten sprinklers over the maximum recommended installation torque. Exceeding the maximum recommended installation torque may cause leakage or impairment of the sprinkler.

Glass bulb sprinklers have orange bulb protectors or protective caps to minimize bulb damage during shipping, handling and installation. Reliable sprinkler installation wrenches are designed to install sprinklers with bulb protectors in place. Remove the bulb protector at the time when the sprinkler system is placed in service for fire protection. Removal of the bulb protector before this time may leave the bulb vulnerable to damage. Remove bulb protectors by undoing the clasp by hand. Do not use tools to remove bulb protectors.

Maintenance

Reliable Model F1FR series sprinklers should be inspected and the sprinkler system maintained in accordance with NFPA 25, as well as the requirements of any Authorities Having Jurisdiction.

Prior to installation, sprinklers should remain in the original cartons and packaging until used. This will minimize the potential for damage to sprinklers that could cause improper operation or non-operation.

Do not clean sprinklers with soap and water, ammonia liquid or any other cleaning fluids. Remove dust by gentle vacuuming without touching the sprinkler.

Replace any sprinkler which has been painted (other than factory applied). A stock of spare sprinklers should be maintained to allow quick replacement of damaged or operated sprinklers. Failure to properly maintain sprinklers may result in inadvertent operation or non-operation during a fire event.

Guarantee

For the guarantee, terms, and conditions, visit www.reliablesprinkler.com.

Ordering Information

Specify the following when ordering:

Model

- F1FR42

Deflector/Orientation

- Upright
- Pendent

Temperature Rating

- See sprinkler technical specifications

Sprinkler Finish

- See Table B

Recessed Escutcheon*

- F1
- F2
- FP

Escutcheon Finish

- See Table B

Sprinkler Wrench

- Model W2 (upright and pendent)
- Model W4 (recessed)
- Model W14 (New frame with guard installed)
- Model W13 (Legacy frame with guard installed)

***Notes:** 286°F (141°C) sprinklers are not listed to be used recessed.